



INSTALLATION INSTRUCTION AIR TO AIR



Summary

1	Introduction	4
1.1	General Notes.....	4
1.2	Suggested tools	4
1.3	Series description	4
2	Read Carefully before use	5
2.1	Important information.....	5
2.2	Proper use	5
2.3	Regulatory	5
2.4	Energetic saving.....	5
3	Expected use of the heat pump	5
3.1	Operating area e safe devices	5
3.2	Heat pump structure	5
3.3	Operation mode	6
4	Equipment supplied.....	6
4.1	Main unit.....	6
4.2	Name and serial number	6
4.3	KITA AIR Templari® internal unit dimension	7
5	Transport.....	8
6	Mounting and installation.....	8
6.1	Equipment check	8
6.2	External unit measurements.....	8
6.3	Free spaces for the assembly	8
6.4	Choice of installation place	9
6.5	External unit mounting	9
6.6	Condensate discharge preparation.....	9
6.7	Correct alignment.....	10
6.8	Probe installation	10
7	Montaggio e installazione dell'unità interna	11
7.1	Internal unit sizes and components	11
7.2	Generalities and choice of the installation place	11
7.3	Assembly internal unit and correct positioning of B2 probe	11
8	Refrigerant circuit onnection.....	11
8.1	Installation requirements	11
8.2	Preparation for installation and refrigerant pipelines installation.....	11
8.3	Vacuum procedure	12
9	Maintenance and cleaning.....	13
9.1	Finned coil cleaning	13
9.2	Condensate discharge cleaning.....	13
9.3	Refrigerant circuit maintenance.....	13
10	Electric connection	14

10.1	General information	14
10.2	Operations of laying	14
10.3	External unit connection.....	14
10.4	Internal unit connection	14
10.5	Probes and remote controller	14
11	Terminal box wiring	16
11.1	Internal terminal box wiring	16
11.2	External unit internal terminal box wiring KITA - AIR.....	16
11.3	pLAN web wiring - “multi-KITA”	18
12	Electronics (UPC)	18
12.1	Digital outputs.....	18
12.2	Digital inputs	18
12.3	Analogical outputs.....	18
12.4	Analogical inputs	18
12.5	Electric diagram KITA AIR.....	19
12.6	Internal wiring connection diagram	20
13	Commissioning	21
13.1	Preliminary controls	21
13.2	Commissioning	21
14	Control unit	22
14.1	Control panel measurement	22
14.2	Control panel structure.....	22
14.3	Control panel display	22
14.4	Main menu	23
14.5	ON-OFF menu.....	23
14.6	SETPPOINT menu.....	23
14.7	Clock/timetable menu	24
14.8	Input/Output menu	25
14.9	Alarms history menu	25
14.10	Board change menu.....	25
14.11	Assistance menu.....	25
14.12	Menu overview	29
15	Alarms.....	30
15.1	Alarms resolution	32
15.2	Notifications.....	32
16	Performances	33
17	Declaration of conformity.....	34
17.1	Declaration of conformity KITA AIR.....	34

1 Introduction

This manual aims to give all the necessary information installation and proper operation of **KITA - AIR Templari®** heat pump, from its start-up and for all its life cycle. The document is divided into chapters , each of which contains general information and procedures to be performed.

1.1 General Notes

- The selection and the use of the unit that serves the plant shall be carried out by competent staff in accordance with regulations in place, so as to fully satisfy the demands of the system.
- Installation, commissioning and maintenance must be performed by competent staff that must be able to assess risk factors or malfunctioning of the machine.
- The unit is directly supplied by the manufacturer with all the options and functionalities . Tampering with any part of the refrigerator circuit or the software are not allowed. Any tampering will invalidate the manufacturer responsibilities.
- Regular inspections and proper maintenance of the heat pump **KITA - AIR Templari®** can prevent damages and any costs for repairs.
- The warranty is void for an installation that doesn't meet the specifications.
- Keep this manual with the necessary diagrams in an easily accessible place.
- In case of malfunctioning, check the error code on the control panel, if necessary contact the installer. If necessary, please request for original parts.
- You can find all informations on the KITA Templari® label, in accordance with the regulation on labeling, in particular you can find:
 - Voltage and frequency of Power supply of the machine;
 - Thermal power in heating and cooling;
 - Maximum power consumption;
 - Sound power level;
 - The refrigerant utilized.

1.2 Suggested tools

- Set of screwdrivers;
- Cutter;
- Scissors;
- Set of wrenches or pipe wrenches;
- Ladder;
- Pumber material to seal the threads;
- Electrical equipments for connections;
- Protective gloves;
- Testers and current clamp;

1.3 Series description

KITA - AIR Templari® heat pump series presents air to air machines which are composed by an external and internal unit (aerothermal unit) for heating and cooling in big spaces applications.

KITA - AIR Templari® is full-inverter with high performance and generously sized component to reach high energy efficiencies. Another feature is the EVI technology (Enhanced Vapour Injection) that enlarges the operating zone and the thermal power of the machine. The R410A refrigerant allows the achievement of high performances and low environmental impact. Full reliability and optimal functionality are ensured by two electronic valves, a 4-ways valve, pressure transducers, temperature probes, controlled by the electronics onboard. The user can control the whole machine functionalities by a remote panel controller: by this control it is possible to change the setpoint and the working mode (summer/winter) and to monitoring the operations.



Internal unit

External unit

2 Read Carefully before use

2.1 Important information

ATTENTION!!

The use and the maintenance of the **KITA - AIR Templari®** heat pump, are subjected to the juridical ordinances of the destination country. Depending on the amount of refrigerant you need to check and note the tightness of the heat pump at regular intervals referring to qualified personnel.

- During transport it's possible tilt the external unit not over 45° (in any direction).
- Transport protection must be removed before to commissioning.
- Don't cover or reduce the suction area.
- Comply with the building regulations specific to individual countries.
- If the heat pump is installed near the wall, be careful to the influence of building physics factors. Make sure that there aren't windows in the fan discharge area.
- If the heat pump is installed near a wall, there is a higher risk of deposit of impurities. Besides, external air moved by the heat pump must escape in order to not increase the building thermal losses.
- It is not allowed the installation of the external unit or of the monoblock in niches or in interior courtyards, because the cooled air accumulates on the ground and in the case of prolonged functioning would aspirated again by the heat pump.
- The frosting limit can change depending on climate region. Respect the regulations of the countries concerned.
- Observe correct rotational direction: in case of incorrect wiring the start of the heat pump is hindered. The unit presents a phase monitoring that indicates the correct connection.
- The heat pump could stop operations in case of too low external temperature. In case of long time power cut, please see the commissioning procedure explained forward.
- Before opening the device, make sure to switch off all the electronics.
- Only qualified staff of the customer service can operate on the device.

2.2 Proper use

KITA - AIR Templari® heat pump is homologated only for the expected use, and it must be used as described by this manual. A different utilization mode is considered non-compliant. Any modification of the device is forbidden.

2.3 Regulatory

This device, in accordance to the 1st article of the 2006/42/ CE Directive, must be use only in residential environment, and hence is subjected to the 2006/95/CE Directive (Low voltage supply).

For design and realization of the heat pump all the CE directives and all the DIN and VDE have been observed.

The electric connection of the heat pump must be made in accordance with the VDE, EN and DIN specifications. Besides, the specifications for the electrical connections fixed by the supplier

must be observed.

People, in particular children, that due to physical or mental diseases or lack of experience can't use the device in safe, mustn't use the device without an expert guide. Make sure that children don't play with the heat pump.

2.4 Energetic saving

KITA Templari® contributes to environmental saving. To properly utilize the thermal energy contained in the air, make sure of a correct disposition of energy sources and plant. In order to obtain an high energy efficiency is necessary to reduce as much as possible the temperature difference between the external air and internal air. For this reason a correct sizing and design of the plant is recommended. **For a temperature difference of 1°C higher, it means an increase in consumption of 2,5%.** Avoid to place the internal unit inside dusty ambients. The dust may accumulate on the heat exchanger decreasing its efficiency. The same in the case of corrosive volatile substances.

3 Expected use of the heat pump

3.1 Operating area e safe devices

- **KITA AIR Templari®** heat pump has to be used with external air temperature between -30°C and 46°C.

Internal air temperature range:

- **Heating:** min. temperature 15°C, max. temperature 35°C
- **Cooling:** min. temperature 20°C, max. temperature 28°C
- **KITA AIR Templari®** heat pump is equipped by a pressure switch that stops the machine operations when a pressure of 4,5 MPa is reached.

ATTENTION!

Make sure to switch off the device and to disconnect it from the electric connection before performing maintenance.

- **KITA AIR Templari®** heat pump is equipped by a discharge temperature probe that controls the discharge temperature.

NOTE!

The device is not suitable for use with an external inverter. If the machine is powered off (disconnected from the net) for long periods, do not interrupt the procedure of the oil warming that starts when the machine is powered once again. This procedure prevents the compressor breakdown.

3.2 Heat pump structure

The heat pump system includes the following components:

- **The KITA AIR Templari®** external unit contains the refrigerant circuit;
- **KITA AIR Templari®** internal unit (aerothermal) for the diffusion of the air inside ambient;
- Remote control panel.

3.3 Operation mode

The heat pump can operate in two modes, actionable through the switching of the 4 way valve: as shown below, these modes are heating and cooling.

Heating mode

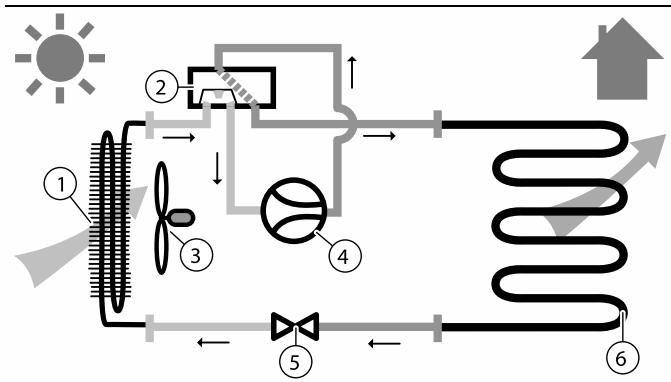

- | | | | |
|---|------------|---|----------------------------|
| 1 | Evaporator | 5 | Electronic expansion valve |
| 2 | 4-W valve | 6 | Internal unit exchanger |
| 3 | Fan | | |
| 4 | Compressor | | |

Cooling mode

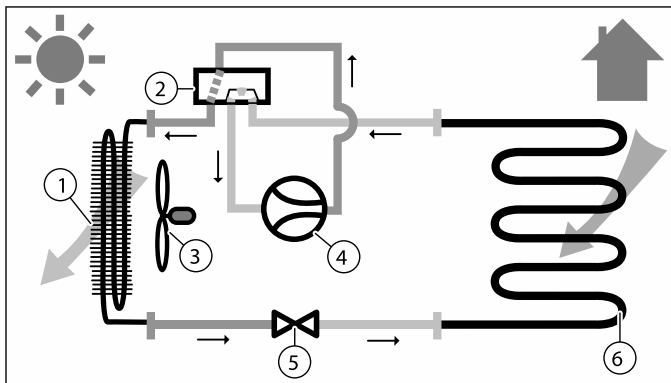

- | | | | |
|---|------------|---|----------------------------|
| 1 | Evaporator | 5 | Electronic expansion valve |
| 2 | 4-W valve | 6 | Internal unit exchanger |
| 3 | Fan | | |
| 4 | Compressor | | |

4 Equipment supplied

4.1 Main unit

The KITA AIR Templari® heat pump is provided in 2 units and it's consists of components which are indicated at page 4.

4.2 Name and serial number

The name of the model and the serial number are indicated on the plate (1). Figure 1 and 2.

figure 1

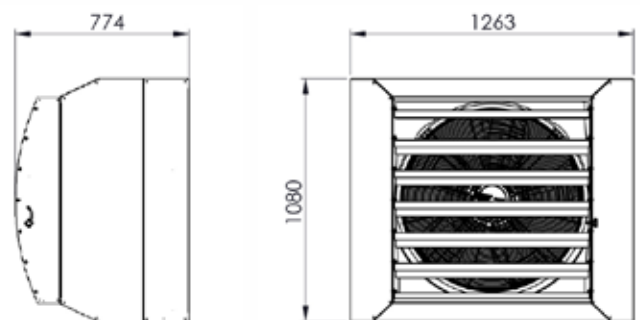
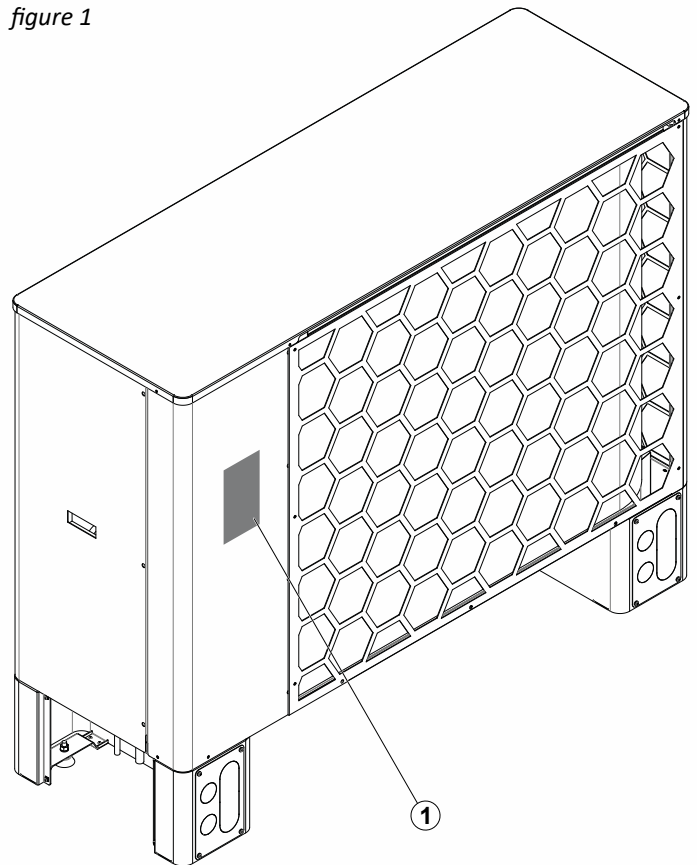
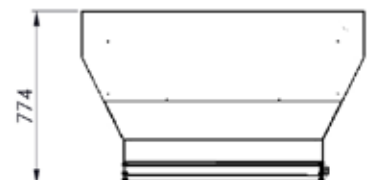
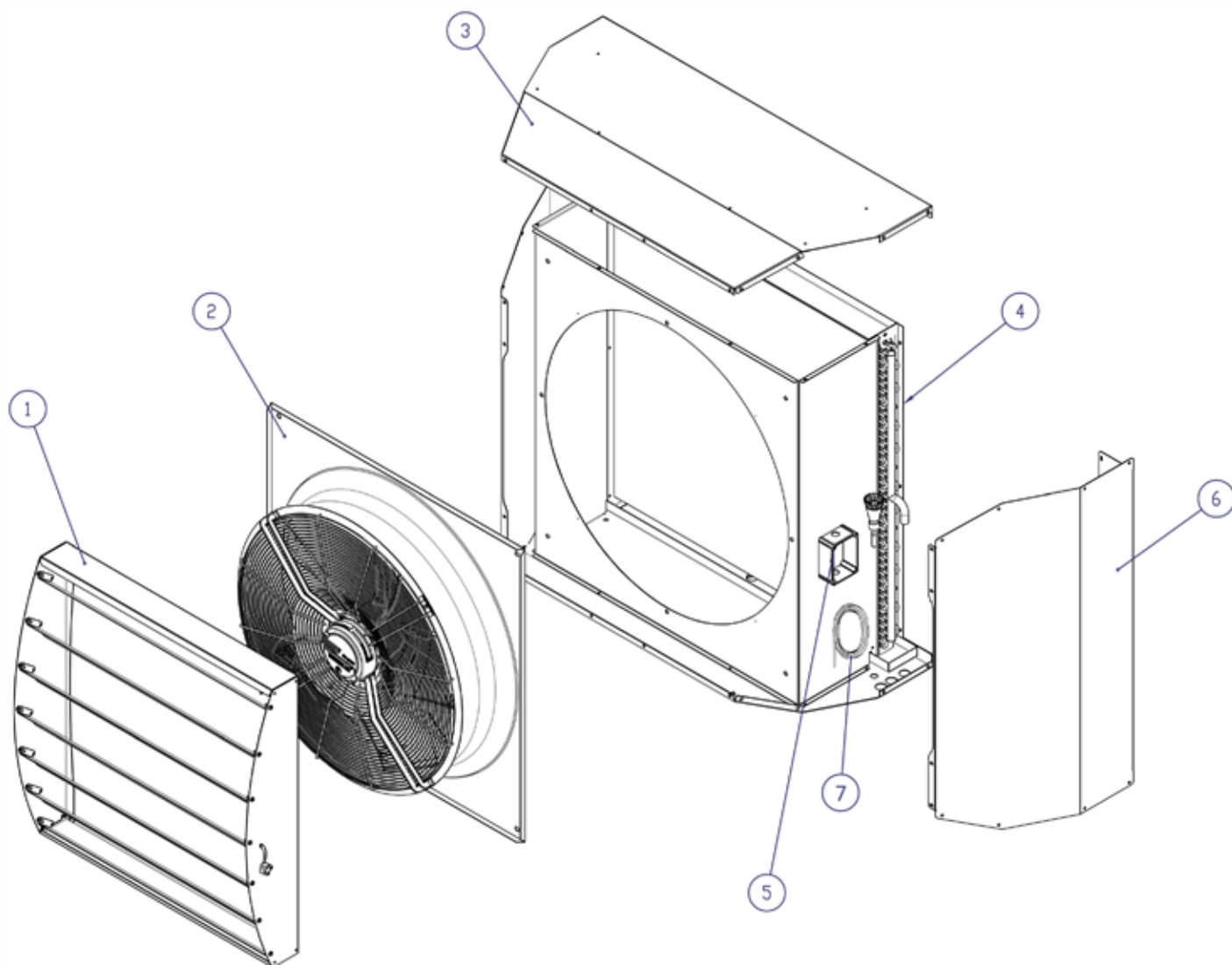

figure 2



4.3 KITA AIR Templari® internal unit dimension



- 1 Deflector
- 2 Fan
- 3 Case
- 4 Battery exchanger
- 5 Electric box
- 6 Side cover (remove to access to electric box)
- 7 Probe cable B2 prewired to unroll

The image is intended only to indicate the main internal components. The actual product may look different.

5 Transport

⚠ WARNINGS!

Regardless of the type of transport, must never be inclined more than 45°. Contrary you can have anomalies in the refrigerant circuit in the next operation. In severe cases this may have as a consequence a failure inside.

The transport to the final place of installation should be done on a pallet. The heat pump **KITA AIR Templari®** can be transported using a forklift.

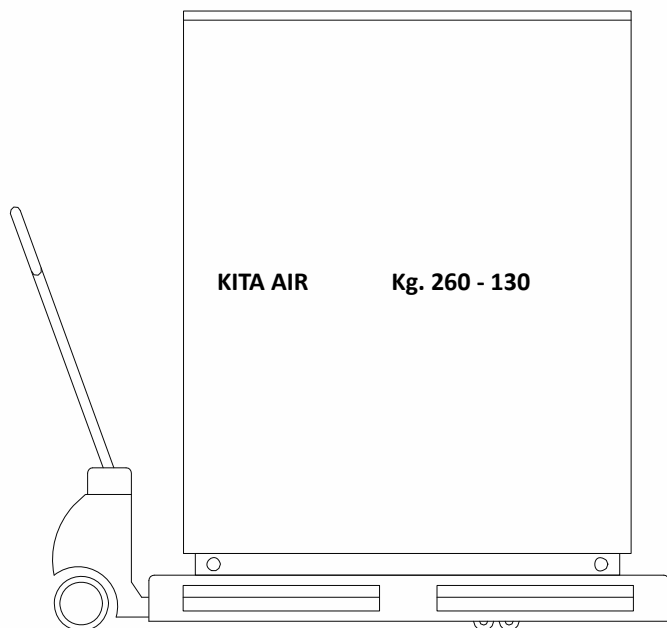

- Protect the sidewalls of the product coming into contact with the forklift to prevent scratches and damages.
- Lift the product only from the back and from the side of the fittings.
- The lifting of excessive weights can cause spinal injuries, for example.
- Consider the weight of the product reported in the technical data.
- In the transport of heavy loads, comply with the instructions and the provisions in force.
- It is recommended to pay attention do not to overexertion when lifting the internal unit. It is advisable to be at least in two persons.

6 Mounting and installation

6.1 Equipment check

- cable for remote control panel connection
- sensor probe

optional

- Anti-vibration mountings for ground fixing;
- wall support for internal unit.

6.2 External unit measurements

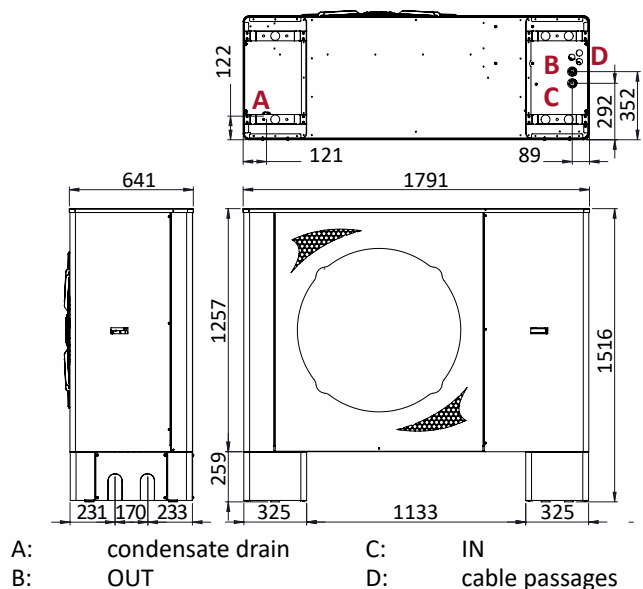

6.3 Free spaces for the assembly

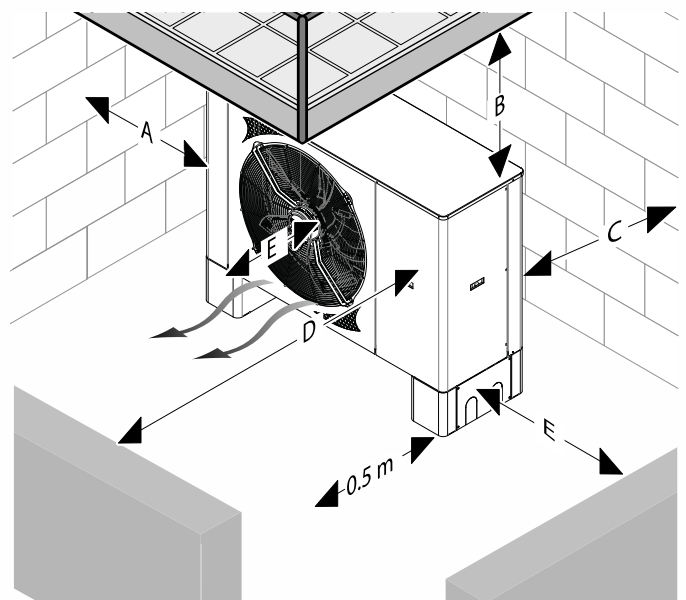

Distance	Measures in millimeters
A	>300
B	>2500
C	>500
D	>3000
E	>1000

Respect the minimum distances mentioned above to ensure a sufficient air flow and facilitate maintenance works.

- If the product is installed in areas prone to heavy snowfalls, verify the snow doesn't accumulate around the product and the minimum distances mentioned above are respected. If these conditions can't be satisfied, install then an additional heat generator in the heating circuit.

6.4 Choice of installation place

- Observe all the rules in force.
- Install the product outside the building.
- Don't install the product:
 - near a heat source,
 - near flammable substances,
 - near ventilation opening of contiguous buildings,
 - Below deciduous trees.
- For the installation of the product observe:
 - prevailing winds,
 - noise of the fan and the compressor,
 - optical impression on the environment
- Avoid place where on the air outlet of the product there is the effect of strong winds.
- Don't orient the fan towards the near windows.
- If necessary, install noise-protection system.
- Install the product on one of the following supports:
 - Concrete pavement,
 - T steel beam
 - Concrete block.
- Don't expose the product to dusty and corrosive air (e.g. near rough roads).
- Don't install the product near wells of air discharge.
- Prepare the laying of electrical cables.
- In places where there are snowfalls, install the heat pump at least 25 cm from the ground to avoid clogging at the inlet and drain zone.

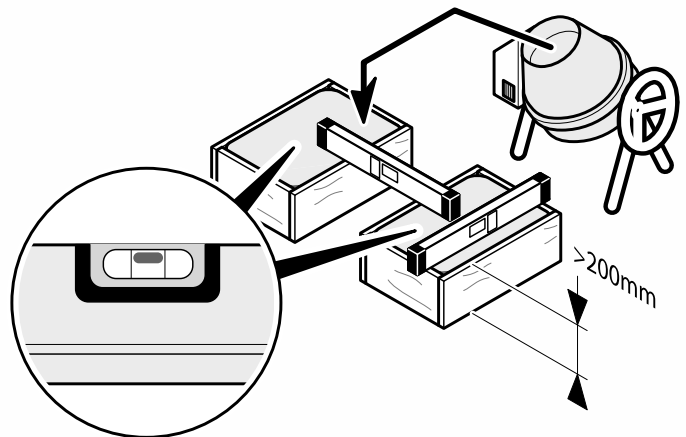
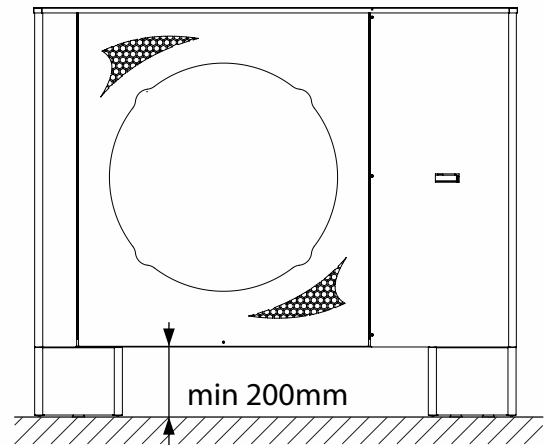

- *Preparation of the base for condensate drain*

6.5 External unit mounting

1. Before installing the device, please see the safety warnings in this manual.
2. Install the product on T beam steel, Concrete Block or with a wall support.
3. Make sure that water doesn't accumulate under the device.
4. To avoid ice formation, make sure that the ground in front of the device can absorb condensed water.

6.6 Condensate discharge preparation

The condensate is discharged behind the heat pump by a unique way. Prepare the condensate discharge with a discharge pipe or with a gravel bed.

⚠ WARNINGS!

Frozen condensate on the path can cause falls. Make sure that the condensate doesn't flow on the path and that it doesn't freeze.

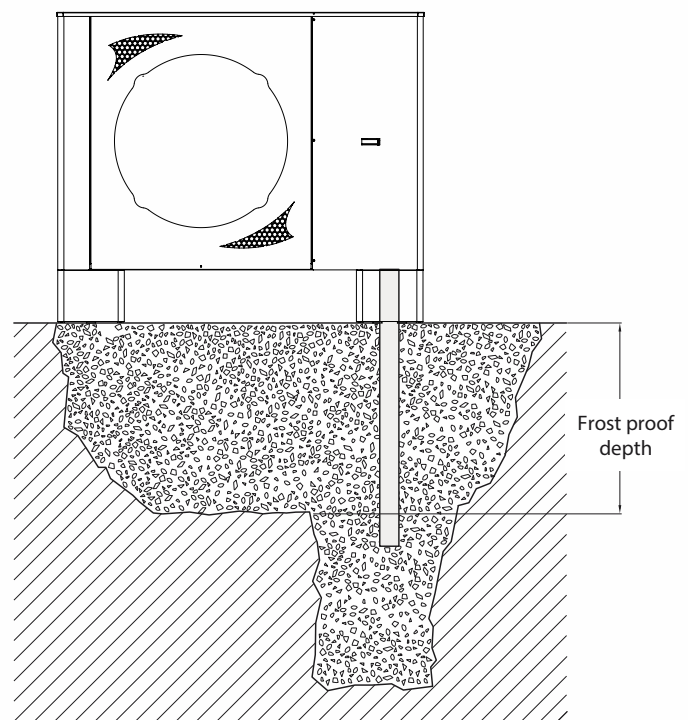
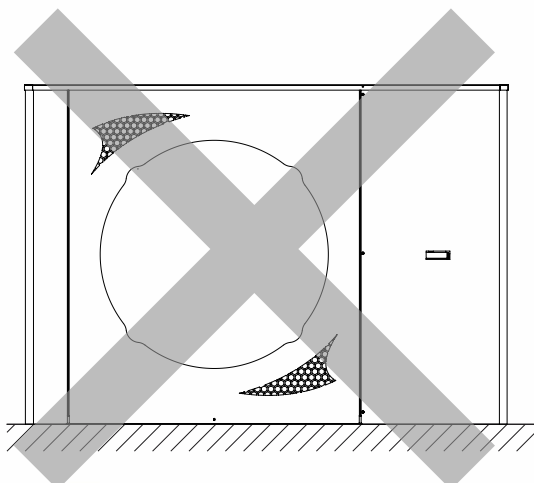

- *Example 3 condensate drain (it is recommended to bury the drain pipe to prevent the formation of ice in the event that you do not purchase optionally the heating resistor for discharge condensate)*

6.7 Correct alignment

Put horizontally the heat pump **KITA AIR Templari®** so that the condensate can flow. The product must be installed with amortized feet, purchased separately. The amortized feet increase the height of the product, facilitating the flow of condensate and reducing vibrations.

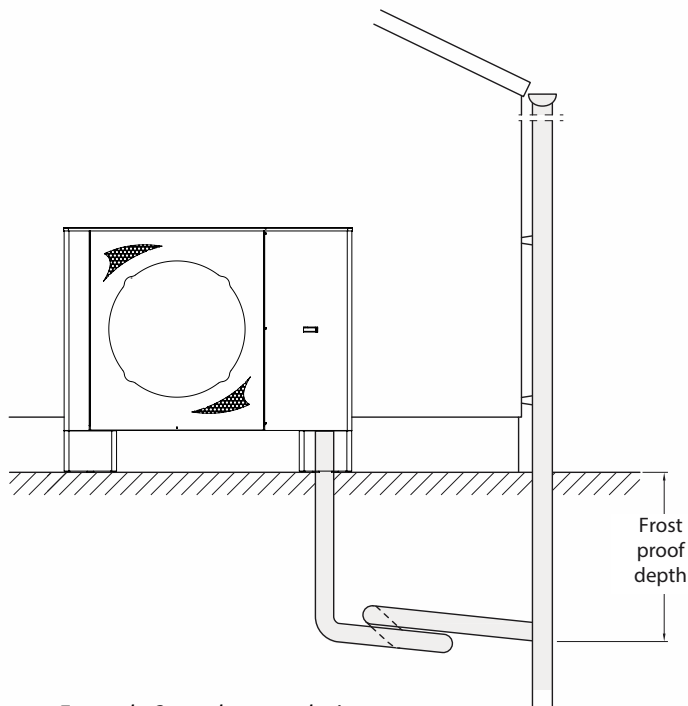

- *Example 2 condensate drain*

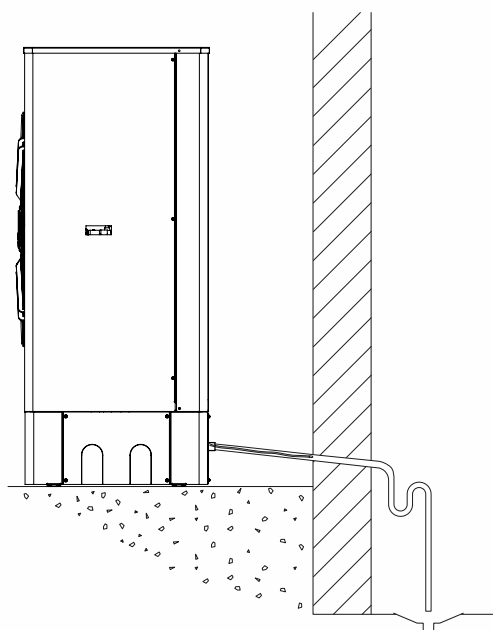

- *Example 3 condensate drain with condensate drain element*

The condensation water accumulated during the operation must be carried away without it can freeze. To ensure the correct outflow the heat pump must be in a horizontal position. The condensation water pipe must have a minimum diameter of 18mm and must flow in the drain channel without it can freeze. Don't discharge the condensate directly into purification basins and moats. The aggressive fumes and the condensation pipe, if it isn't protected against frost, can cause irreparable damages to the evaporator.

In places where there are snowfalls, install the heat pump at least 25 cm from the floor to avoid clogging in the suction and condensate drain area.

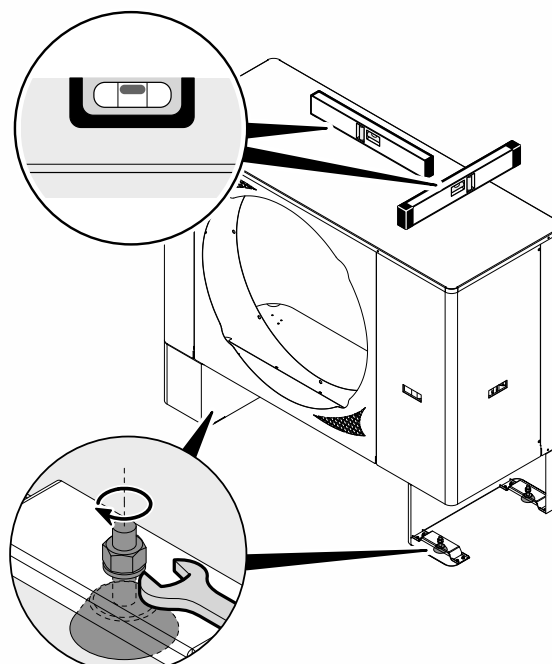

6.8 Probe installation

All probe used for the operation of the plant must be installed properly in the appropriate wells using a suitable thermal paste.

⚠ WARNINGS!

Installing the probes not in a proper way will voids the warranty.

7 Montaggio e installazione dell'unità interna

7.1 Internal unit sizes and components

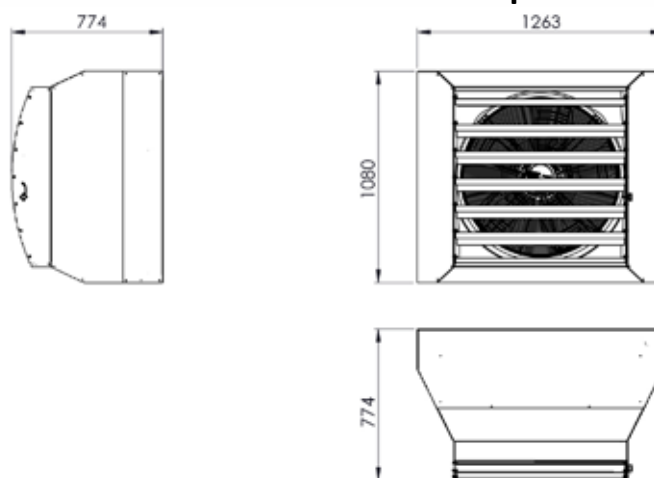

7.2 Generalities and choice of the installation place

⚠ WARNING!

- Install the unit in an internal environment.
- The unit must not be install near heat or steam sources.
- Install the internal unit respecting the minimal distances from walls and obstacles for facilitate the assembly and maintenance operations.
- Secure a proper air circulation.
- Install the unit in a vertical position, as shown in figure at paragraph 7.1.

7.3 Assembly internal unit and correct positioning of B2 probe

The unit has to be fixed to the wall using dowels and L supports. Lift the unit and hang it on the wall. Caution, it is advisable to be at least in two persons or more, as the excessive weight can cause serious injuries.

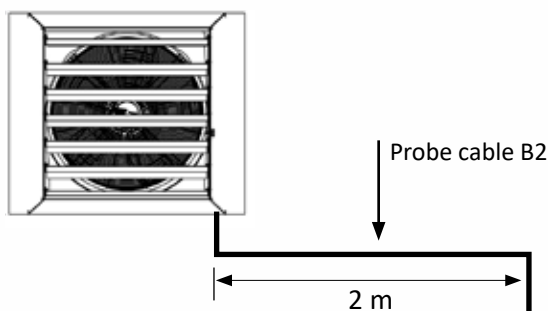
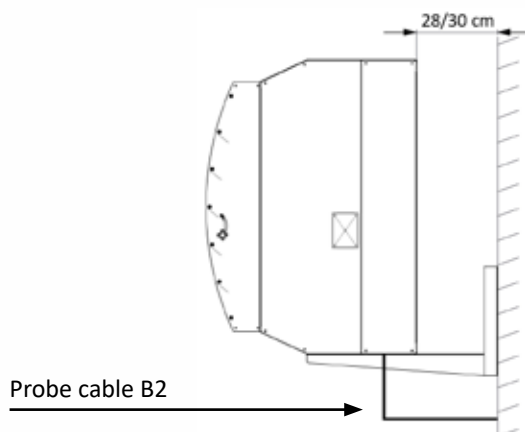

The B2 probe cable must be positioned sideways respecting a distance of 2 m from the internal unit, it must align at man height paying attention it cannot be in direct contact with the wall because it is primary that the cable of this probe be at least 3cm away from the wall.

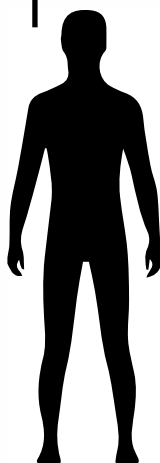

8 Refrigerant circuit onnection

The refrigerant pipes connections have to be made up by qualified and licensed personnel. The connections requires the use of a weld tool.

8.1 Installation requirements

- The connecting tubes between internal and external units have to respect the below indicated dimensions.
- Non respecting of indicated measurements can lead to significant decrease of the machine performance.
- If the internal unit is installed at a higher level than the external unit, it is necessary to provide some specific siphons each 5 meters high on the refrigerant conduit return to facilitate the oil return eventually remained in the circuit

	Nominal length	Maximum length of the piping (m of equivalent length)	Maximum height difference (m of equivalent length)	Additional refrigerant charge recommended * (g/m of equivalent length)
All models	1	30	30	45

* sub-cooling must be in a range between 3°C and 4°C with heat pump in steady state.

NOTE: the parameter equivalent length has to consider the curves too. Each 90° curve in the circuit has to be counted as a 1 m straight portion. Each 180° curve in the circuit has to be counted as a 2 m straight portion. Each oil trap in the circuit has to be counted as a 4 m straight portion.

8.2 Preparation for installation and refrigerant pipelines installation

The coolant pipes connections must be sealed to prevent leakage of the coolant and the consequent malfunctioning of the heating pump. The connection pipes must be insulated and have diameters specified in the following table.

	Gas (mm)	Liquid (mm)
KITA AIR	Ø 28	Ø 16

For the preparation of the pipes for installation, proceed as follows:

- Measure the distance between internal and external units, and perform all necessary installation curves..
- The laying of the pipes must include the minimum number of bends, because each curve increases the pressure drop of the circuit and reduce the machine performance.
- Cut the pipes to a length slightly greater than that measured.
- Completely remove smudging from the cut section, holding the pipe downward and blowing air into the pipe.
- Respect the safety measures that are indicated into the table, or add the request quantity of refrigerant.
- Weld the provided manufacturer's anchors at the end of the connection pipe. Weld the inner side female anchors and the outer side male anchors. Where is possible, perform welding in nitrogen atmosphere. Otherwise at the end of welding operation blow the nitrogen braise points..
- Insulate carefully the refrigerant anchors and connections.

8.3 Vacuum procedure

- We recommend to run a leak test with nitrogen to 40 bar pressure to check the quality of the welding connections
- For the vacuum perform, connect the pump charging vacuum connection procedure (1/4) inside the external unit.
- Perform the vacuum until reaching 0.4mbr pressure (duration of procedure for about 1 h for 15m total length connection. If the length increases as result will increase duration of the vacuum perform).
- At the end of the procedure remove the pump and open the valve to pour out the refrigerant liquid.

9 Maintenance and cleaning

A regularly maintenance is necessary in particular for correct and efficient heat pump operations, so as to reduce damages and usury of the components. The user decides the maintenance frequency. It depends in particular on two factors:

- The utilization mode: if the operating mode during the year is single (heat pump or chiller), an annual maintenance is suggested; if the operating mode is double (heat pump and chiller) during the year, the maintenance shall be halfyearly.
- The installation place: if the installation is located in heavy polluted places or in the presence of dust that could obstruct the finned coil, it is suggested to frequently check the finned coil conditions and, if necessary, to supply a more frequent maintenance.

⚠ WARNING!

Disconnect the device from the electric supply before every operation to avoid injuries due to the activation of some particular operating logics.

9.1 Finned coil cleaning

During the machine functioning it's possible that the finned battery will partially obstructed because presence of leaves or incrustations of various kinds, also provoking a malfunctioning of the heat pump. It is possible then clean the battery with a under pressure jet of air in a parallel direction of the fins, you should also remove any deposits in the battery compartment keeping an adequate distance so as not to risk to fold or damage them.

- Clean the frontal surface;
- Remove the panel on top as shown by the figure.
- clean also the internal unit finned battery, especially if it is placed in dusty ambient

⚠ WARNING!

Don't touch the fins to avoid to be cutted. Don't fold the fins, this could reduce the performances. In case of folded fins, contact a service center.

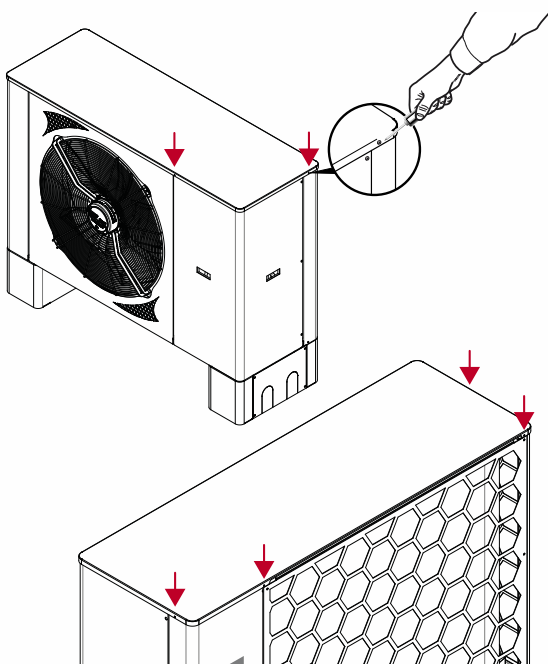

9.2 Condensate discharge cleaning

Please make sure that the condensate discharge pipe is in the correct position e without any obstruction to ensure a proper condensate flow from the finned coil fins.

9.3 Refrigerant circuit maintenance

The machine is equipped with a safety valve which ensure the reduction of internal refrigerant circuit pressure in case of external generation of heat (e.g. in case of fire).

To ensure proper operation of the valve, contact the manufacturer and make sure to replace it each 4 years.

⚠ WARNING!

The direct contact between the skin and coolant out of the safety valve cause serious injury. Do not stand near the valve.

10 Electric connection

10.1 General information

- Before starting any operation please adopt any safety device and make sure that the unit is in stable equilibrium and that there isn't any element connected to the electric supply.
- The electric supply line must adopt safety devices suitable for the machine characteristics that can interrupt the horticircuit current.
- Refer to the electric diagram of the unit.
- At first please connect the grounding connection.
- Before switching the unit on, all protections must be active.

10.2 Operations of laying

- Please install cables far from lines with different voltage or from devices that can create electromagnetic interferences.
- Avoid parallel laying with other cables, the arrangement is only permitted at 90°
- Pass the power cables and the net control cable of the machine only trough proper holes.

10.3 External unit connection

- Connect the power supply to the external unit electric terminal by the following table named "power supply cables indication". Cables passage takes place through the apposite holes.
- See 12.1 for the connection of drain pan's electric heater.

10.4 Internal unit connection

- For electric connection see the following table named "power supply cables indication". See the chapter 11 the terminal picture where to connect RS485 fan contacts (2 core cable) and the sensor probe (2 core cable). The cable carries low voltage control signals: find a route far from sources of interference, do not joints along the way, possibly using a 3 core cable + shield section 1.50 sq mm (shield connected to GND to indoor unit side).
- Connect the internal unit 230V fan power supply (phase, neutral, ground) to the terminal board of the external unit through the tripolar cable (minimum section 1,5 mmq).
- Pay special attention on ground connection: the GND must be the same for the 2 units. **ABSOLUTELY AVOID THE CONTACT BETWEEN THE SIGNAL GND AND THE THE GND OF POWER SUPPLY!**

WARNING!

The section of the supply cables is to be considered indicative and relative to the last part of the line towards the machine, that should be as shorter as possible. The external protections, the position and cable section of the previous supply line should be sized and realized by an authorized person and according to the technical standards of the national authorities.

10.5 Probes and remote controller

Temperature probe B2 of internal ambient temperature must be connected with a multipolar cable (2x1,5 shielded) along the shortest route and away from the power cables. Particular attention should be paid to the junctions because of parasitic resistance influence which may compromise the Control Board value readings.

Connect the remote panel with a telephone cable to the external unit. The remote panel and the probes cable can be laid together with the same precautions.

WARNING!

We recommend to use a ferrite Toroid to protect the remote panel from any external disturbance.

Power supply cables indication

- KITA AIR

External unit

Supply	400 Vac - 50 Hz
Cable	5x6 mmq
Secondary line protection 230 μPC protection 24 Vdc	3 fuses - 5x20-4A 1 fuse - 5x20-4A

Internal unit

Supply	230 Vac - 50 Hz
Cable	3x1,5 mmq

11 Terminal box wiring

11.1 Internal terminal box wiring

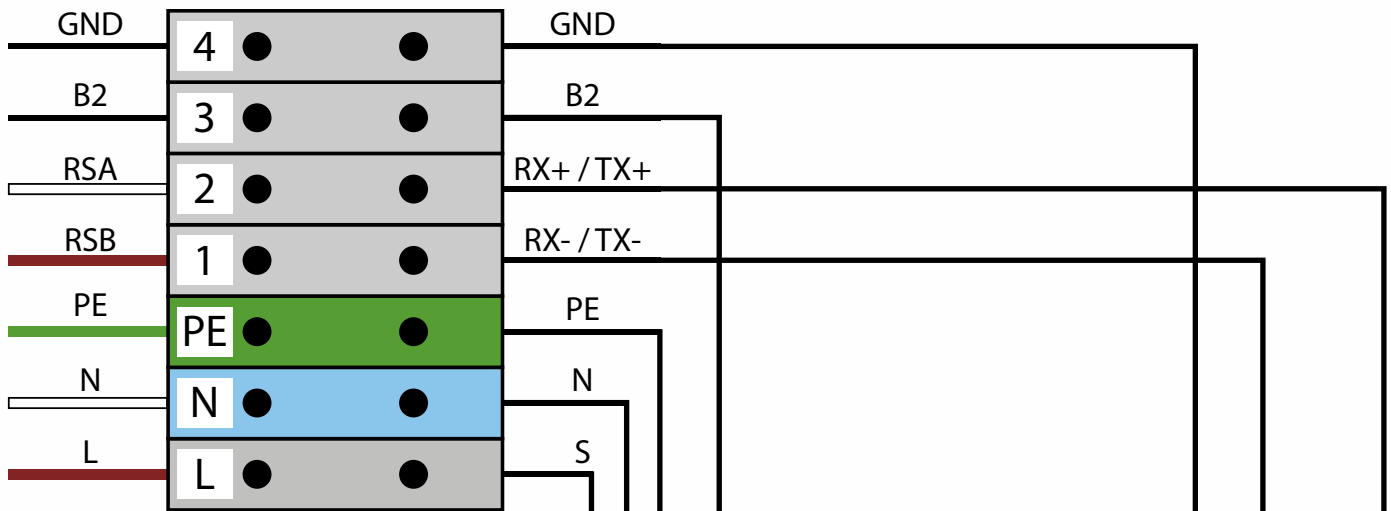

11.2 External unit internal terminal box wiring KITA - AIR

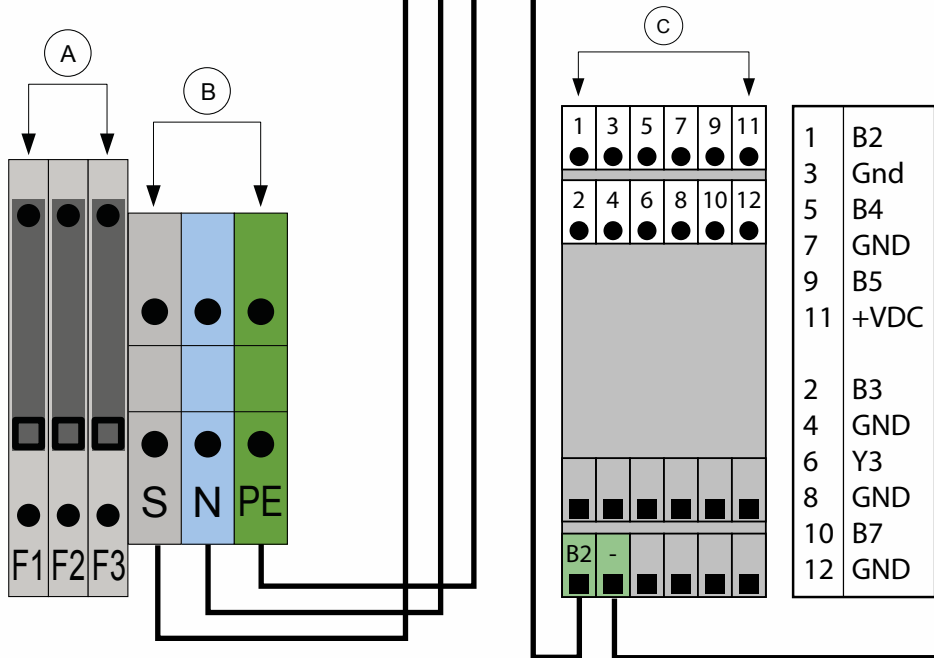

230V auxiliary power supply internal fan

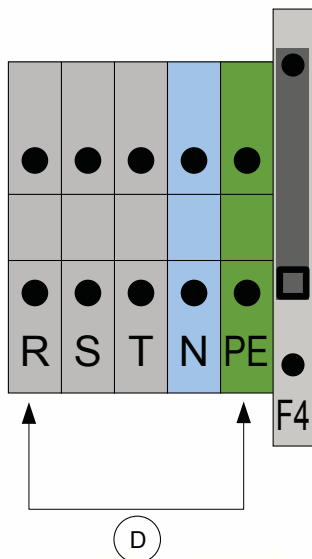

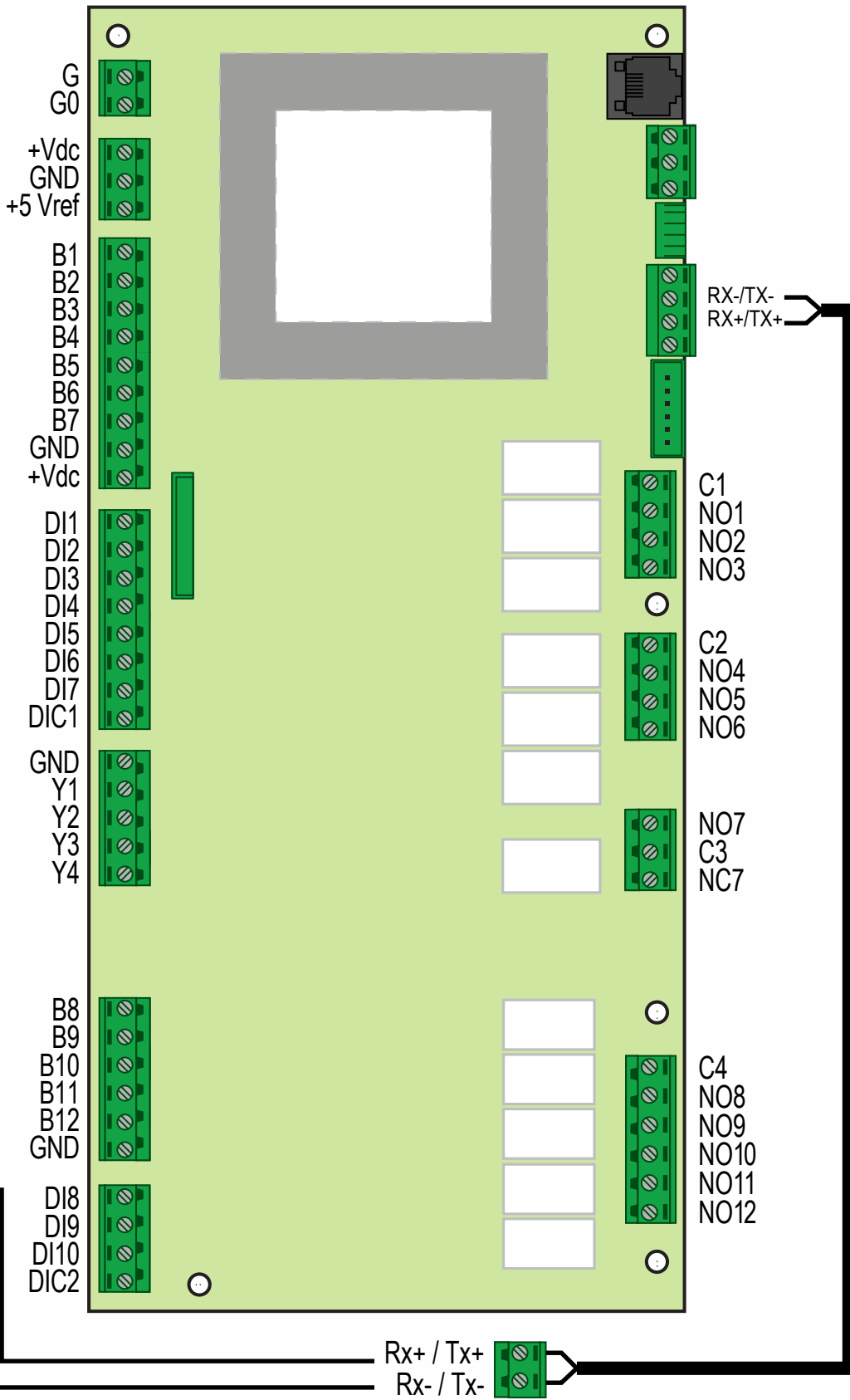

µPC Connector description:

B1	Subcooling
B2	internal ambient probe
B3	
B4	
B5	
B6	Head compressor probe
B7	
B8	outside t. probe
B9	drain probe
B10	suction probe
B11	transducer high
B11	+5V
B11	GND
B12	transducer low
B12	+5V
B12	GND
DI1	summer-winter
DI2	thermal sensor
DI3	press. switch high
DI6	solar boost SGR bit0
DI8	remote on-off
DI9	P-Lan protocol
DI10	flow switch (present on old models)
F4	Elektrische Sicherung - 5x20 250 mA
Y2	
Y3	PWM Circulator
GND	
+5VR	

Connect the Modbus RS485 port on the uPC using the proper cable (image on the side)

11.3 pLAN web wiring - “multi-KITA”

If the air conditioning system has more units which interact with each other in a pLAN logical “master-slave”, you need to connect the machines via the bipolar cable screened according to the following scheme:

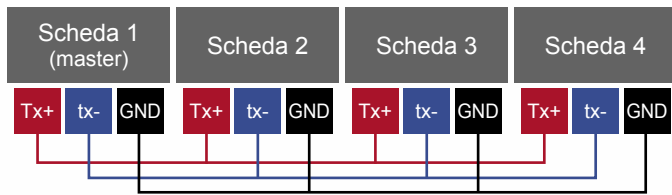

The wiring should be done in the port dedicated to the “P-2 LAN” tab (see point 11 on the scheme in chapter 12).

12 Electronics (UPC)

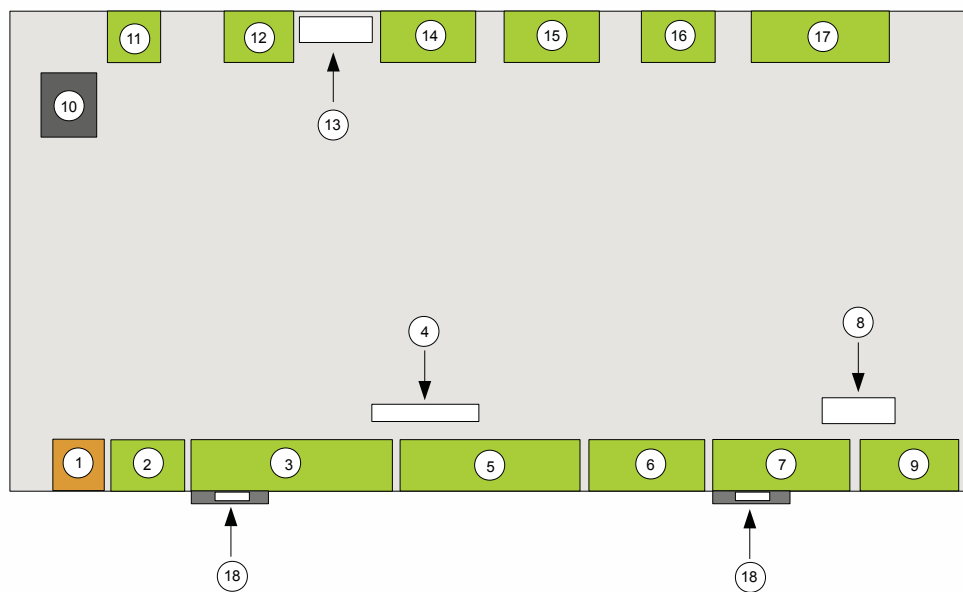

- 1 Power 24 Vdc
- 2 Sensor power
- 3 Analog inputs from B1 to B7
- 4 Port BMS
- 5 Digital inputs from DI1 to DI7
- 6 Analog outputs from Y1 to Y4
- 7 Analog inputs from B8 to B12
- 8 Injection valve
- 9 Digital inputs from DI8 to DI12
- 10 P-Lan 1 Operator panel
- 11 P-Lan 2
- 12 Port RS485 Modbus
- 13 Expansion valve
- 14 Block outputs C1 NO1 - NO3
- 15 Block outputs C2 NO4 - NO6
- 16 Block outputs C3 No7 - Nc7
- 17 Block outputs C4 NO8 - NO12
- 18 Bar hooks Din 35

12.1 Digital outputs

KITA AIR

NO1	/
NO2	/
NO3	/
NO4	/
NO5	Condensate discharge heater
NO6	alternative power source
NO7	/
NO8	/
NO9	/
NO10	4 way valve for cycle inversion
NO11	Compressor carter heater
NO12	/

12.2 Digital inputs

KITA AIR

ID1	Winter/Summer commutation
ID9	Thermic compressor discharge
ID3	Pressure switch for high pressure
ID4	/
ID5	/
ID6	/
ID7	/
ID8	Remote on-off
ID10	Flow switch

12.3 Analogical outputs

KITA AIR

Y1 (0-10V)	/
Y2 (0-10V)	/
Y3 (0-10V/PWM))	/
Y4 (0-10V)	/

12.4 Analogical inputs

KITA AIR

B1 (NTC HS)	
B2 (NTC)	Internal ambient temperature
B3 (NTC)	
B4 (NTC)	
B5 (NTC)	
B6 (0-5V)	Injection pressure transducer
B7 (NTC)	
B8 (NTC)	External temperature
B9 (NTC HT)	Compressor discharge temperature
B10 (NTC HS)	Compressor suction temperature
B11 (0-5V)	High pressure transducer
B12 (0-5V)	Low pressure transducer

12.5 Electric diagram KITA AIR

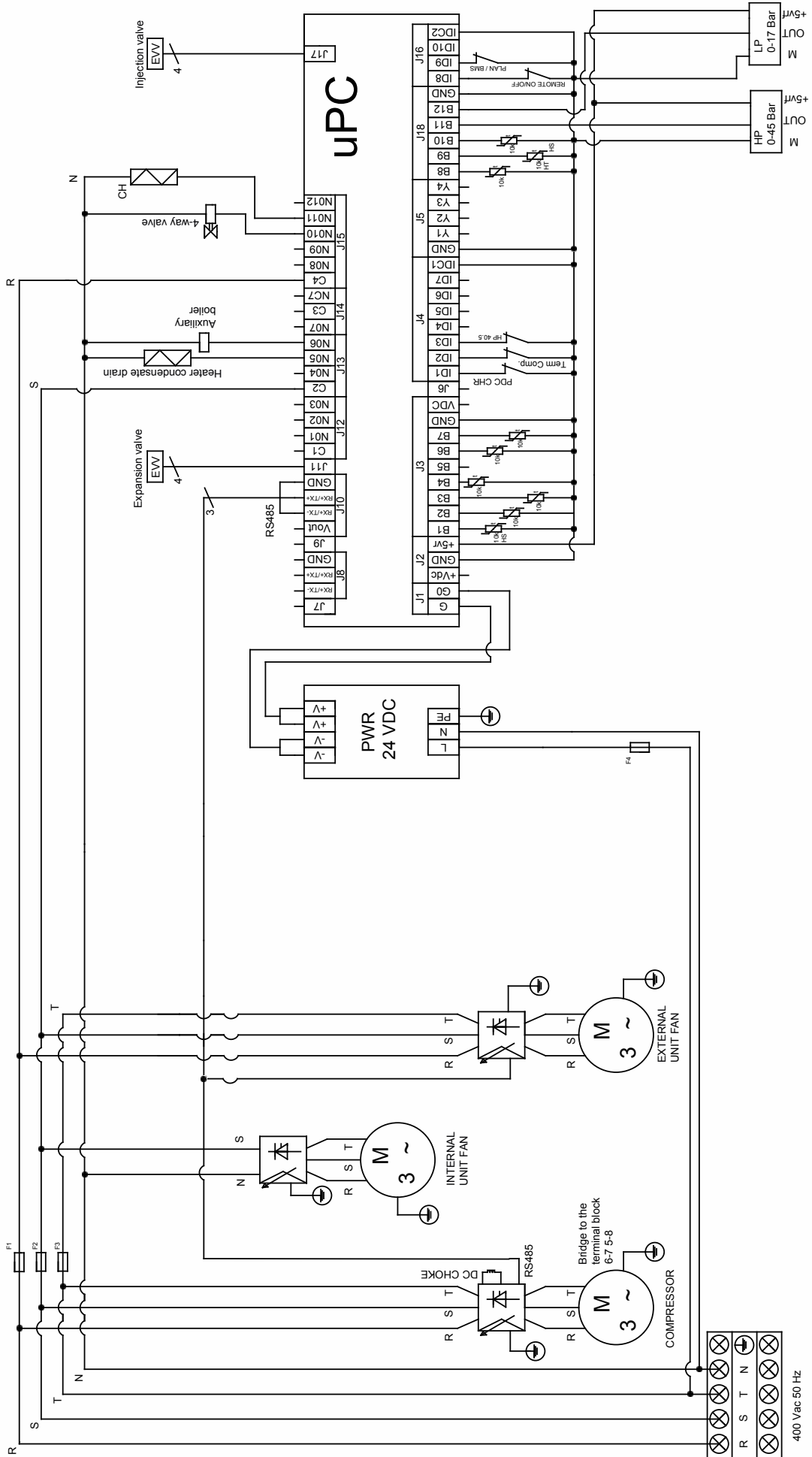

12.6 Wiring connection diagram internal unit

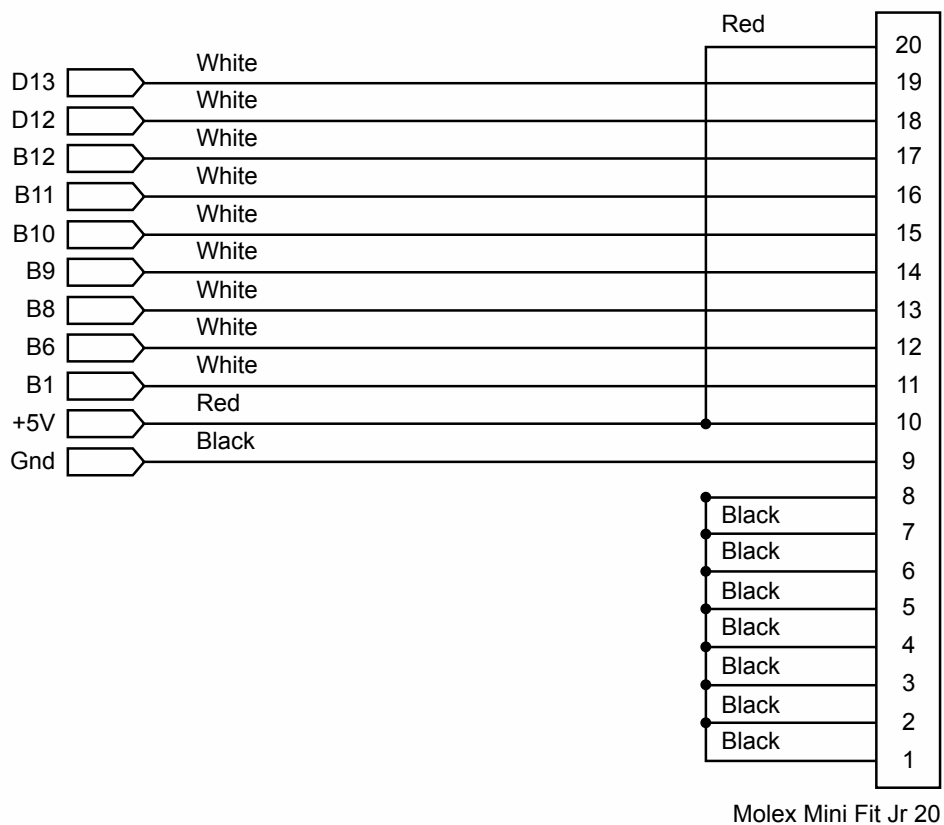
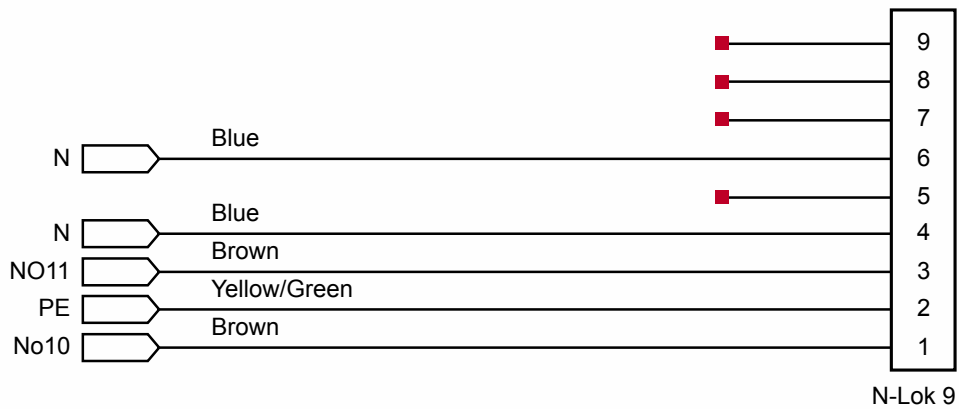
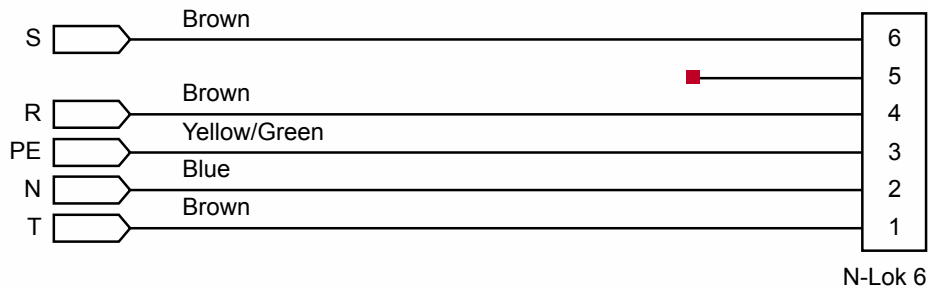
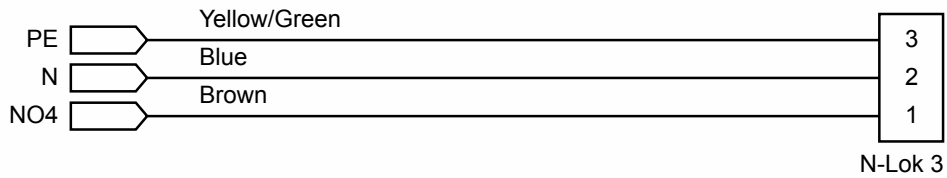

13 Commissioning

The plant commissioning should be realized by technical personnel that has received a complete training.

13.1 Preliminary controls

Make sure the Heat-Pump power supply cables are of a suitable section as reported in this manual, on the basis of the power used and the length of the cables themselves and that are used the necessary electrical protective devices.

Equally check the signal cables of external unit (sensors) and internal unit too, and make sure they have the required characteristics.

Refer to this manual for using the correct type of pipes (diameter / thickness) of the refrigerant circuit between the external unit and internal unit.

After checking the above steps you can turn on the power of the machine. The unit is equipped with a phase monitoring devices, so if the control panel does not turn on and the phase devices stages presents one single red LED on, then you need to disconnect power and reverse two phases of power in order to restore the correct sequence. You can then proceed with the restart.

NOTE!

Please note that after having powered the Heat-Pump this will activate the heating of the oil automatic function (the duration of which depends on the time required to raise the temperature in the oil contained in the compressor, and then depending on the starting temperature).

NOTE!

If the internal and external units were positioned at different heights, with a vertical drop of more than 3 meters, it is necessary to use siphons for the oil recovery every 3 meters in the cooling line called "GAS."

13.2 Commissioning

Running of the compressor:

Every HP is tested in the company before the supply, but we suggest in any case to make a short running in, so not to solicitate overly the new compressor. In this regard we suggest to let in manual the rps compressor at a medium value (50-60 rps) for one/two hours at least.

- Access to menu "Assistance": PRG --> G. Assistance --> g. Manual management --> SERVICE PASSWORD
- Screen Gg05 set up CH/HP in manual "MAN" and set up the rps (60). Now turn on the heat pump (Mode ON) and wait for some minutes until the compressor icon appears in the lower left.

Verify the proper operation:

- Access to menu "D. inputs/outputs" to control the different temperatures from sensors
- Screen D01: B1 it shows the value of liquid sub-cooling in the heat pump, it has to stay in a range between 3,5 and 5. If the hp is started up during the hot season, for the check of sub-cooling set up the fan speeds (Menu G. Assistance --> g. Manual management --> G. Assistance --> g. Manual

management --> SERVICE PASSWORD --> Screen Gg02: set up "Speed Fan" in manual MAN and "Power required" at 5%.

- Screen D08: verify that the value SH (overheating) is included between 4 and 5
- Screen D15: verify, once set these conditions the drain overheating has to be about 20. During the normal operation, with free compressor, this value can reach 45K.
- Screen D16: control the proper operation of the injection valve, considering that over 12°C external the valve is off.
- Menu G. Assistance --> g. Manual management --> G. Assistance --> g. Manual management --> SERVICE PASSWORD --> Screen Gg06: activate a defrosting forced cycle, setting up "Start the defrost cycle" in YES (once ended the cycle the function automatically come back to AUT).
- Restore all settings from manual MAN to automatic AUT.
- Verify that the working tensions and network frequencies are in the following ranges:
230/1/50 -> valori \pm 6%
400/3/50 -> valori \pm 6%

NOTE!

A problem easily detectable is the steady opening of the electronic valve at 100%

possible reasons and solutions:

- lack of refrigerant gas in the cooling system; for this reason the electronic valve, to compensate the lack of gas, is open over the normal values.
- heat pump used in incorrect way. Example: installation of a heat pump undersized respect to the building that requires more power at rating levels. In this case for example the compressor works at 100% even with positive air temperatures; this fact requires an higher quantity of refrigerant than the project data. The heat pump Kita has to be sized to work at full speed just at minimum external temperatures. The electronic valves are optimized to work in the medium range of operation and for this reason oversized valves aren't installed, they would work too close causing instability in the system. Possible solutions:
 - control the proper operation of the valve
 - control that in the HP Kita there is the right quantity of gas
 - replace the heat pump if wrongly undersized respect to the heating requirements of the building.

14 Control unit

The terminal of the unit is connected serially through line P-LAN and can be installed in remote to control the unit. In the control software have been implemented all the settings necessary to grant the functionality and the safety of the machine, and by the terminal you can monitor the operation of the unit and set the parameters of operation preference (summer/winter setpoint...). Here below some example picture will be shown to use the control and the start up of the machine.

14.1 Control panel measurement

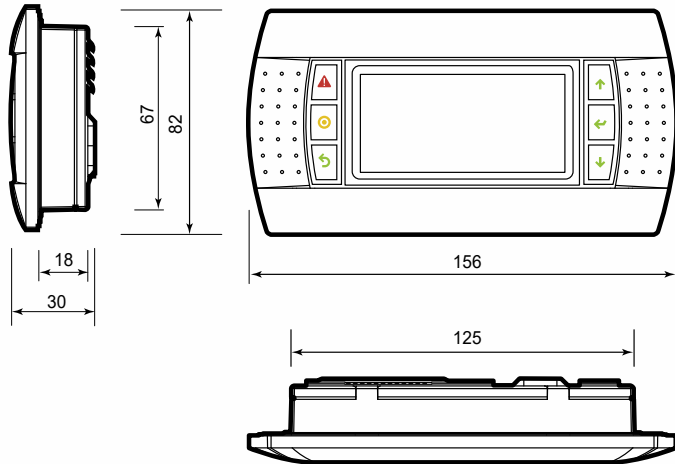

14.2 Control panel structure

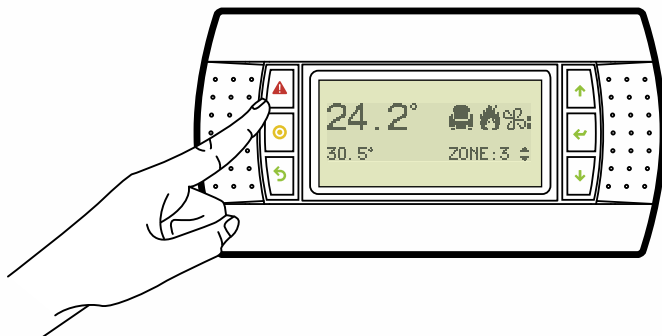

	-Alarm	Show the active alarm list.
		Allows to enter the main menu.
		Return to the previous mask
	-Up	Slide the masks upward or increase the selected parameter value.
	-Down	Slide the masks downward or decrease the selected parameter value.
	-Enter	Enter the selected submenu or confirm the selected value.

14.3 Control panel display

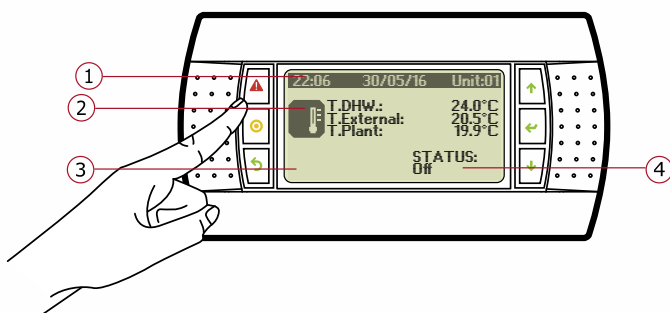

1 - Control panel display

2 - Main parameters and active request

	No active request
	Heating plant request
	Chiller plant request

3 - Main active actuators

	It activates with the compressor activation.
	It activates when the solar panels are installed and active
	It activates when the defrosting procedure is active

4 - Unit status

The unit can be in one of the following states:

- OFF
- ON
- ENERGY S.
- AUTO-OFF
- AUTO-ON
- AUTO-E.S.
- Din-OFF
- BMS-OFF
- ALARM-OFF

OFF

The unit is in stand-by status: the antifreeze function is active (internal circulating pump activation and, if requested by very low external temperatures, compressor activation), but the heating/cooling regulation is not active

ON

All the functions are activated and the unit regulates following the plant request

ENERGY S.

All the functions are activated and the unit regulated following a "lower" temperature set (it can be set up in the B02 mask, as described below). This status allows an energy saving.

AUTO-OFF

The unit regulates in accordance to the time slots set (in C02 mask), and following the nominal temperature set (B01 mask). The unit is in OFF status.

AUTO-ON

The unit regulates in accordance to the time slots set(in C02 mask), and following the nominal temperature set (B01 mask). The unit is in ON status.

AUTO-E.S.

The unit regulates in accordance to the time slots set by the customer (C02 mask) and following the Energy Saving temperature set

Din-OFF

The unit is turned off by a digital input (if expected).

BMS-OFF

The unit is turned off by a BMS supervisor (if expected).









ALARM-OFF

The unit is in OFF status due to an alarm event.

14.4 Main menu

To enter the menu press the button **Prg**. Press the buttons **↑** and **↓** to navigate manus. At the end of operations, press **Esc** to come back to the main screen.

Here below the 8 menus:

A.		On-Off unit
B.		Setpoint
C.		Watch/Time table
D.		Inputs/Outputs
E.		Alarm history
F.		Board change
G.		Assistance
H.		Manufacturer

14.5 ON-OFF menu

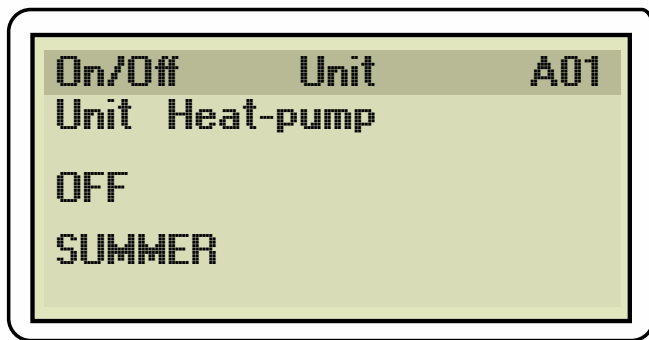

Mask A01: it permits to set the condition and the operation mode. The state OFF set in this menu is always conditioned (ex. antifreeze operation).

Mask A02: It turns off without conditions the pump for a certain period of time. Expired the time the function A01 is rehabilitate.

14.6 SETPOINT menu

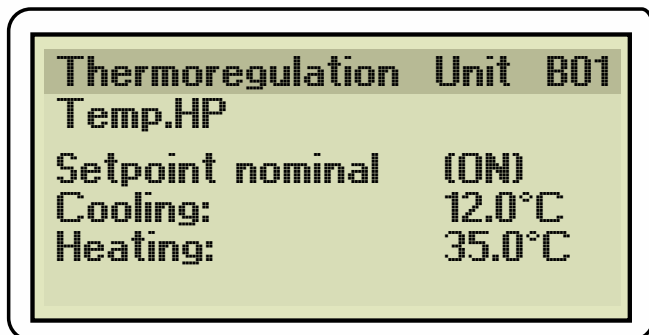

Mask B01: Variations of nominal setpoint.

Mask B02: Variations of Energy saving setpoint. We suggest the use of the Energy saving during the night or during long absences from home. To reduce the consumption of the

unit we suggest to use the climatic curve instead of setting the Setpoint, because it permits a continuous flow.

Mask B05: it permits the choice of fan operation mode. It is possible to chose between the following conditions:

- **POWERFULL:** it is the most efficient condition, that also involves the noisiness of the greater fan.
- **NORMAL:** it is the condition of operation set by the manufacturer, it permits a very good compromise between efficiency and noisiness.
- **QUIET1 - QUIET2 - SILENT:** in these conditions of operation the fan is slowed down respectively of 10, 15, 20 percentage points. Those conditions permit to work with a noisiness more and more reduced. We underline that setting this function the efficiency of the machine too is progressively reduced.

Mask B06: Only in AIR version. Automatic Mode Change to pass from cooling mode to heating mode defining a confort zone in which neither mode is active. To activate the function the difference between the cooling and heating setpoint has to be equal to Delta Confort. It also allows to set the operation mode of the internal fan. The internal fan can follow the request (compressor speed) low medium or high or control the condensation.

Mask B07: it manages the Automatic End Season. You have to set the daily medium external temperature over which you want the heating function is turned off; if present the domestic function stay active in any case.

Mask B08: Optimizer management. The optimizer is an algorithm that allows to store energy using the thermal inertia of the building when the conditions are more favorable.

- **Active optimizer:** it activates or deactivates the function.
- **Final Setpoint :** it shows the reference value of the heat pump including the Delta Optimizer.
- **Delta Optimizer:** it shows the delta (positive or negative) due to optimization algorithm.
- **Influence:** it sets the minimum value (delta negative) and maximum (delta positive). This function is needed to limit the influence of optimizer if necessary.

Mask B09: it allows to set a hysteresis in shutdown. Once reached the Setpoint the machine, instead of turn off, continue operating at minimum until reaching this target on setpoint set up. If in the meanwhile the request increases again (ex. request from the domestic) the compressor come back to the operating regime required.

14.7 Clock/timetable menu

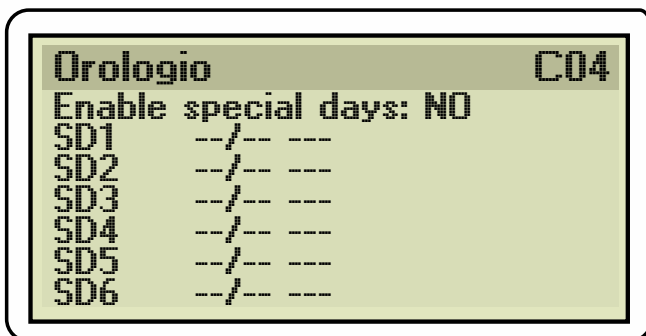
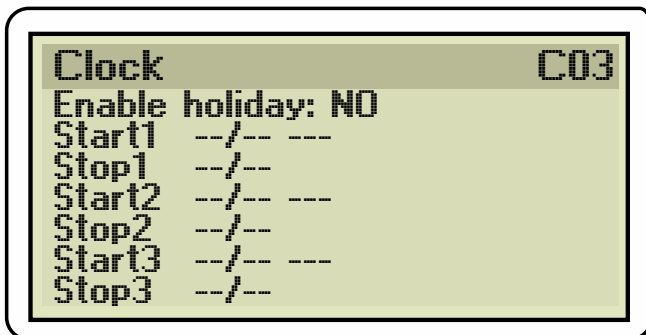
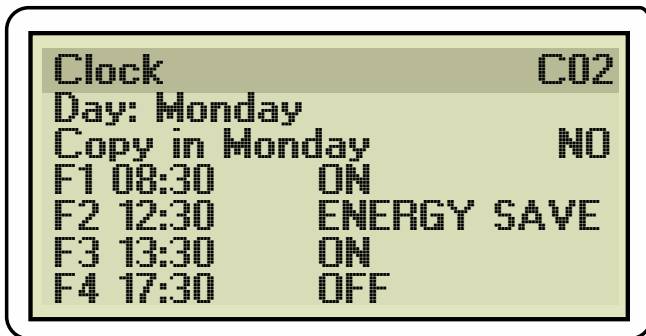
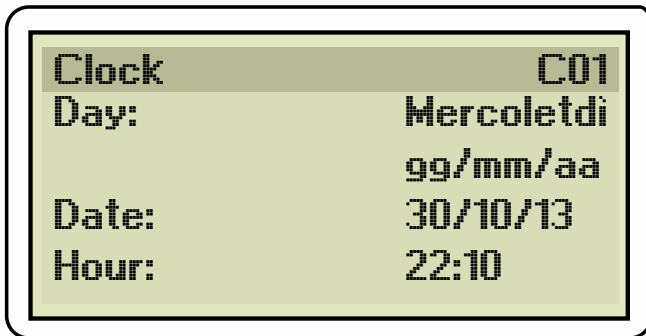

Mask C01: Date and time set up.

Mask C02: It allows to set up the timetables. To have access to timetables change set up from menu ON-OFF the conditions OFF and AUTO.

Press the button to choose the day when you want to set the timetables.

Use the buttons and to change the value displayed.

Confirm with the button .

Press twice the button to shift to the timetable setup:

- F1: it means the timetable from 00:00 of the selected day, till the time set in F1.
- F2: it means the timetable from the time selected in F1 until the time set in F2.
- F3: it means the timetable from the time set in F2 until the

time set in F3.

- F4: it means the timetable from the time set in F3 until the time set in F4.

After entering the time in the first time period, confirm with to set the wanted operation mode in the time period concerned (choose between ON - OFF- ENERGY SAVE).

Confirm the choice with and proceed con with the setting of the other timetables.

To set the timetables in the other days press and proceed as explained above.

Contrary it is possible to copy the setting in different days: once entered in mask C02

- press the button to have access to the choice of the day you want to copy
- use then the buttons and to choose the day
- Confirm with the button
- With the buttons and choose the day when you want to copy the timetables
- Confirm with
- With the button choose YES and confirm with

Mask C03: It allows to enable three periods with pre-set operation.

- Press and to enable/disable the period/s.
- Confirm with to access to the starting day of the particular period.
- Use the buttons and to choose the starting day
- Confirm the choice with
- Choose the operation mode with the buttons and
- Confirm with the button
- Use the buttons and to choose the final day
- Confirm your choice with
- Repeat the same action to set if necessary the remaining periods.

Press **Esc** to come back to menu.

Mask C04: It permits to enable a pre-set operation for 6 different days maximum.

- Press and to enable/disable the special day/s
- Confirm with to enter the choice of the starting day of the particular period.
- Use the buttons and to choose the starting day
- Confirm the choice with
- Choose the operation mode with the buttons and
- Confirm with the button
- Repeat the same actions to set if necessary the remaining particular days.

Press **Esc** to come back to the menu.

Mask C05: It enables the automatic transition from winter time to summertime. The parameters are at first set by the manufacturer.

14.8 Input/Output menu

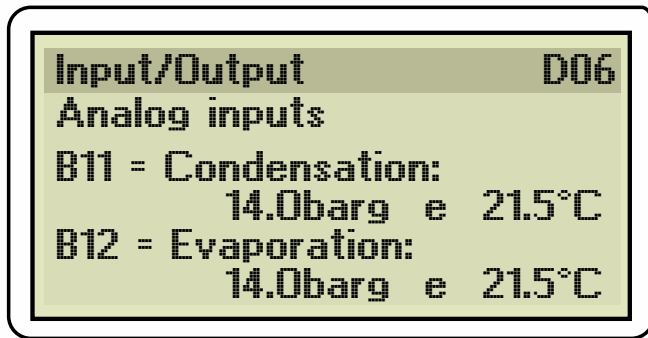

Accessing to this menu it is possible to read a lot of values. From the screen D01 to the screen D06 it is possible to read the following sensors:

- B1:** it represents the SUBCOOLING in the heat pump operation (heating). With an appropriate refrigerant charge the indicative value of B1 probe should stay between 3.5 and 5*.
- B2:** internal ambient temperature.
- B6:** compressor head temperature
- B8:** External air temperature.
- B9:** flow temperature of the compressor.
- B10:** suction temperature of the compressor.
- B11:** condensate pressure and relevant temperature.
- B12:** evaporation pressure and relevant temperature.

*If the value is very different from these parameters please contact your service centre

Mask D07: speed management of the fan.

Mask D08: view of the condition of the cooling circuit: percentage of electronic expansion valve opening, B10, B12.

Mask D09: view of working regime.

- Capacity required.
- Real capacity.
- Compressor speed.
- Waiting time ON: minimum time elapsing between a shutdown and the other, or time necessary to equalize the pressure of high and low to the right starting value.

Mask D10: it is show the working zone in the envelope and alarm count down "out of envelope".

Mask D11: it dispays information about pressures.

- differece between pressure of high and low
- relation between pressure of high and low
- alarm count dow "delta P low"

Mask D14: shown the temperature of compressor drain and relevant condition and envelope zone.

Mask D15: overheating of compressor drain and relevant control type active.

- SSH = Suction Super Heating
- DSH = Discharge Super Heating

Mask D19: Parameters Inverter/Engine

Mask D20: Parameters Inverter/Engine

Mask D21: Parameters Inverter/Engine

Masks D30, D31: masks relevant to the external battery fan. You can find the rpm and instantaneous power absorbed.

Mask D33: summary of the unit parameters

14.9 Alarms history menu

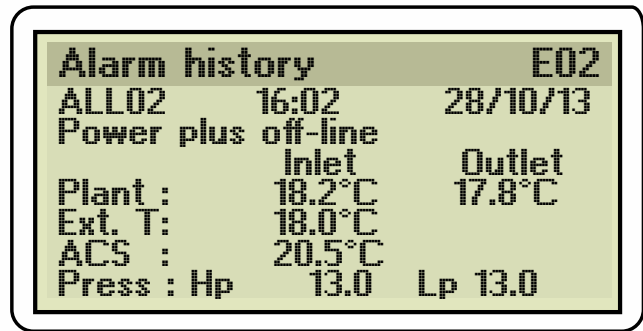

In this menu it is possible to display the alarms due to a possible protection intervention. The alarm list is in the chapter 13.

14.10 Board change menu

The board change menu allows to display the other heat pump/s when they are connected in pLAN and the settings of electronic board/panel allow it.

14.11 Assistance menu

The Assistance menu presents a submenu structured as follows:

- a. Language change
- b. Information
- c. Input / output assistance
- d. Hours worked
- e. Config. BMS
- f. Param. Assistance
- g. Manual management

A. LANGUAGE CHANGE

This menu allows the language change, if available.

Mask Ga01

Possible language: Italian, English, German e French.

B. INFORMATION*

This menu contains masks where there are relevant information to the software, to the control board, to the valves and the inverter, reserved to the technical assistance.

C. INPUT / OUTPUT ASSISTANCE

This menu contains masks of input and outout reserved to the technical assistance.

Gc16: it displays in steps and percentage the injection valve opening.

Gc17: inverter status.

Gc18: inverter status.

Gc22: inverter status.

Gc23: inverter status.

Gc24: digital inputs

Gc25: digital inputs

Gc26: digital inputs

Gc27: digital outputs

Gc29: digital outputs

Gc32: fan status

D. WORKED HOURS

This menu allows to monitor the working time

Mask Gd01:In this mask operation total hours of the heat pump are displayed.

Mask Gd02:In this mask it is displayed the number of

defrost made by the machine during the operation in heat pump.

E . CONFIGURATION BMS

This menu allows to set the communication protocol of the port "BMS" of the electronic control. This menu is protected by a password. Only the authorized staff can enter it.

F . ASSISTANCE PARAMETER

This menu is protected by a password. Only the authorized staff can enter it.

- Counter settings
- Sensors calibration
- Thermoregulation
- default user / change password

a. COUNTER SETTINGS

Reserved to the authorized staff

b. SENSORS CALIBRATION

Gfb01: sensor calibration B1 and B2

Gfb02: sensor calibration B3 and B4

Gfb03: sensor calibration B5 and B6

Gfb04: sensor calibration B7 and B8

For the sensor B8 it is also possible to choose:

- **on board:** the sensor on board is set
- **remote:** remote sensor is set

Gfb05: sensor calibration B9 and B10

Gfb06: sensor calibration B11 and B12

Gfb07: offset S1, S2

Gfb08: offset S3, S4

Gfb09: enable and set sensor calibration B2 and B3

c. THERMOREGULATION

Mask Gfc02: Configuration request integration parameters.

It allows to define the thresholds of auxiliary integration intervention (boiler / electric heater) to the heating based on the request (the ability to reach the set point in a given time interval) and on its proportional part.

It is defined the working condition to which the heat pump requires help from the integration, namely the condition of "crisis".

- **ON-Request:** it represents the request generated by PID of the reached water that activate the integration.
- **ON-Propor.:** it represents the distance from the set, in percentage, over that activate auxiliary integration.

For example: the percentage of the proportional band Hc06 as per factory default is set at 10. The 60% of 10 is 6°C . It represents the proportional enabling the integration of auxiliary heating. Higher this value is it means the machine is far from set. If this value was low and the previous higher, the boiler could start even if it isn't necessary, for example if the machine stayed near the set (low proportional) for long time (high integral pushing), no reaching it. In qthis case the machine would be a little subsized but it could heat the water in any case, without a necessary intervention of the boiler.

The combination of the two previous parameters, then, identifies when the machine is really in crisis and needs integration. Happening both conditions the integration is active.

- **OFF-Propor.:** it's the percentage of the proportional band Hc06, that as default is set at 10, under that the integration shut down.
- **OFF-Diff.:** Degrees the integration has to

produce more on Setpoint set on the heat pump.

Mask Gfc03: integration activation in case of need (heat pump in "crisis").

- **Setpoint act.:** external temperature value under that the boiler is enabled to start if the machine is considered in crisis (parameters in Gfc02)
- **Differential:** deltaT positive, that is the integration is enabled until the external temperature reaches a temperature equal to Setpoint+Differential.
- **Boiler activation delay:** verify previous conditions, the boiler is activated if they stay for the time set.

Mask Gfc04: integration activated according to the outside temperature.

In this case the integration started when the outside air temperature falls below the set value. Once activated the auxiliary source, it works in conjunction with a heat pump, unless it is not been set her to turn off.

Integration remains active until it reaches the set water setpoint, although the air temperature rises above the value set.

- **Setpoint act.:** external temperature value that enable the heating control, heating independent from other factors
- **Differential:** deltaT positive, that is the integration is enabled until the external temperature reaches a value equal to Setpoint+Differential.
- **Turn off compressors:** it allows to turn off the heat pump under the defined temperature in Setpoint act. : the integrated system totally replaces the heat pump.

Mask Gfc07: reserved

Maschera Gfc15: reset antifreeze alarm.

- **Reset antifreeze alarm primary circuit:** it allows to establish if the rearming is manual or automatic.
- **Manual:** (default) the machine restarts only if the user resets resetta manually the alarm.
- **Auto:** the machine restarts automatically when the flow temperature is increased to the value Set_alarm_antifreeze + Diff_Activat

Mask Gfc20: resetting set overheating reset .

- **Reset overheat. alarm primary circuit:** it permits to establish if the resetting is manual or automatic.
 - **Manual:** (default) the machine restarts only if the user resets the alarm manually.
 - **Auto:** the machine restart automatically when the flow temperature is decreased to the value Set_alarm_overheat-Diff_Activat.

Mask Gfc21: selection for the setting of the mode (winter or summer) through user panel or remote external switch (digital).

- **Summer/Winter selec. Season from:** it is possible to choose between "KEYBOARD" (operator panel) or "IN. DIG. 1" . In this case you have to consider it isn't enough to manage the commutation summer/winter.

Mask Gfc22:

- **Enable protection:** it allow to enable or not the function winter antifreeze protection that activates the compressors when the plate heat exchanger reaches a temperature too low.

Mask Gfc23: enabling external reports

- **It enable warning reports on output NO7:** it allows to enable the digital output NO7, to whom it could be connected for example a notification led, when the machine is in alarm for minor causes.

Mask Gfc25: defrosting setting.

- **Fan consumption:** fan consumption in Watt calculated by the electronic and used to start the defrosting procedure.
- **Start up delay:** start up delay of the compressor after that it is allowed the defrosting start up. To avoid that the defrost starts just after the ignition of the compressor, situation where you can have the conditions of the defrost start up, due to the start up dynamics.
- **Fan delay:** waiting time before of starting the defrost
- **Defrost delay with temperature differencies:** Waiting time for the activation of the defrost for delta T.

Mask Gfc27: parameters defrost.

- **En oil defrost:** element that allows to enable the return of the oil through defrost cycle. If enabled and if the unit required the return of the oil normal defrost procedure is activated with maximum settable speed with the following parameter "Defrost Speed".
- **Low speed defrost:** if at the moment of defrost start up the compressor had a lower speed than the Threshold the compressor speed during the defrost will be defrost speed.

Mask Gfc34: drip parameters.

- **Drip manag.:** it enables the operation of the fan before the inversion of the 4-way in output from the defrost cycle, that rotating at a high rpm promotes the disposal of the water drops still in the battery.
- **Fan Dripping Speed:** it is the speed where the fan is forced il ventilatore in this specific phase of the defrost process.
- **Fan reverse Dir:** it allows to enable or not the reversing of the rotation direction of the fan. If enabled, the dripping is made with a fan that turns in the opposite.

Mask Gfc37: defrost parameters.

- **Integration of the system during the defrosting.:** It enables the integration generator to the system (boiler or electric resistance).
- **Def. end max time exceeded:** it allows to choose between HISTORY and HISTORY+ALARM, that is to choose the registration/reporting mode of the event "the defrosting is finished because the maximum time is exceeded".

Mask Gfc50: It allows to enable the condensate drain in fix or intermittent mode in base on the external

temperature.

- **Res.drain cond.:** it enables the activation of the resistance for the condensate drain.
 - **ALWAYS ON (Set1):** in this condition, the resistance is always active under this parameter
 - **Set:** value of temperature reached that the resistance condensate drain is always active.
 - **Diff:** differential of temperature. When the xternal temperature is equal to $\text{Text} = \text{Set} + \text{Diff}$ you go out form this function
- **MODE ON-OFF (Set2):** in this condition the resistance is activated under the set, at time intervals as defined from the following parameters.
 - **Set:** value of temperature reached that the function is activated.
 - **Diff:** differential of temperature. When the external temperature is equal to $\text{Text} = \text{Set} + \text{Diff}$ you go out from this function
 - **T.On:** time of on of the resistance in minutes.
 - **T.Off:** time of off of the rsistance in minutes.

Mask Gfc51: limitation in power consumption.

- **En.Watt limit rps:** Enabling of maximum allowed speed limitation to compressor for work of the effective consumption in watt.
- **Thr.:** maximum threshold reachable by the total consumption (compressor, fan, auxiliary, circulator, auxiliary...)
- **Band:** Band in which the value of instant consumption can swing, but always staying under the threshold set
- **Fan:** Consumption value read by the fan. The reading is possible only thanks to the protocol od communication modbus (protocol to communicate) RS 485 (physic network constituted by a certain number of wires), it is set in one to read the effective consumption value
- **Aux:** Consumption values of the auxiliaries. Set equal to 20 W costant.
- **Update time:** interval of time passed that you have the update, up or down, if all the conditions aallow it, the variable that contains the maximum speed allowed by the comporessor.
- **Update rps:** positive or negative increasing of the variable that contains the maximum speed available by the compressor.

Operation:

- if $\text{Thr} \leq$ the current consumption of the unit the limitation of the maximum rpm of the compressor starts decreasing of "Update rps" every "Update time"
- if the current consumption is included between (Thr-Band) and Thr correction actions aren't made
- if the current consumption is $<$ than (Thr-Band) the compressor is free from binds (the maximum speed allowed can increase)

Mask Gfc56: it aallows to change the intervention threshold of defrosting.

- **Model:** fan model present in the heat pump.
- **Amp:** parameterization defrost.

d. DEFAULT USER / CHANGE PASSWORD

Mask Gfd01: it allows to change the password of the acces to assistance menu.

- **Cancel history alarms:** it cancels completely the history of the alarms.
- **Insert a new password:** it allows to replace the password of the acces to the assistance menu

G . MANUAL MANAGEMENT

This menu is protected by a password. Only the authorized staff can have access.

Mask Gg01: It allows to force in manual (MAN) some digital outputs so to verify the correct electrical connections. Refers to the guide supplied with the unit for possible other digital outputs presents

- **N05:** it allows to activate the condensate drain heater.

Mask Gg02: it allows to force the fan at the wanted speed, selectable by required power.

- **Fans speed:** it activates the manual management of fans speed.
- **power required:** % active if manual management is enabled.

Mask Gg03: manual or automatic management of the expansion valve.

- **It enables valve manual position:** it enables the manual management.
- **Valve manual position:** if the manual management is activated, it shows the opening of the valve measured in steps.

Mask Gg04: injection valve manual or automatic management.

- **It enables valve manual position:** it enables the manual management.
- **Manual valve position:** if the manual management is active, it shows the valve opening in steps.

Mask Gg05: manual or automatic management of the heat pump.

- **CH/HP Request:** it enables speed manual management of compressor for the heat pump in heating and cooling.
- **speed:** if the manual management is active, it shows the compressor speed for the heat pump

Mask Gg06: it enables the defrosting cycle.

- **It enables the defrosting cycle:** it enables a defrosting cycle.

Mask Gg07: management of oil recover

- **It enables oil forcing:** it enables a forcing in oil recover cycling.

Mask Gg08: integration management.

- **N06 Plant Integr.:** auxiliary heater output (es. boiler).

Mask Gg09: only in AIR version. Management of winter fan.

- **Fan speed:** it enables the manual management of fan speed.
- **Power required:** % active if it is enabled in manual management.

Mask Gg10: this mask allows to manage screed dryer function.

- **Start cycle:** set the function ON or OFF.
- **Elapsed time:** It shows the elapsed time after the

activation of the function.

- **Start temperature:** the starting temperature of the function.
- **Target temperature:** the target temperature of the function. The temperature increases linearly.
- **Raise hours:** the amount of hours the function must use to raise from starting temperature to target temperature.
- **Stabilise hours:** the amount of hours the function must stay in target temperature.
- **Cool down:** the amount of hours the function must use to cool down from target temperature to start temperature.

Mask Gg11: this mask allows to ignore the oil temperature control of the compressor.

Maschera Gg12 initialization: this mask is used to initialize the heat pump. The initialization erase all data previously saved in the heat pump.

USE EXTREMELY CAREFULLY, CONTRARY THE COMPRESSOR CAN BREAKS AND THE GUARANTEE EXPIRES.

14.12 Menu overview

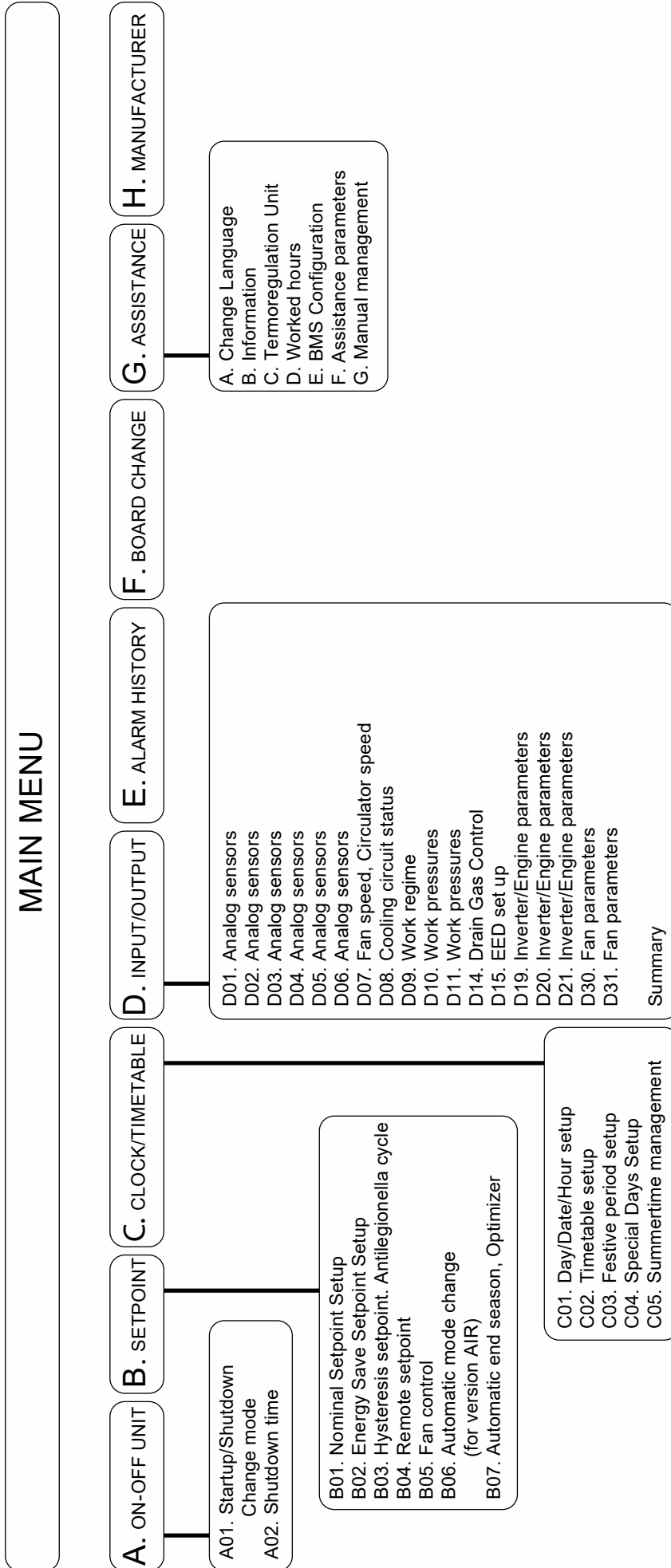

15 Alarms

Alarm code	Visualized message	Reset	Delay	Relay	Action
ALA01	Probe B1 broken or disconnected	Automatic	60 sec	Yes	Stop the machine
ALA02	Probe B2 broken or disconnected	Automatic	60 sec	Yes	If there is a geothermal modulating pump it is set at the maximum speed
ALA03	Probe B3 broken or disconnected	Automatic	60 sec	Yes	Stop the regulation of the domestic circuit
ALA04	Probe B4 broken or disconnected	Automatic	60 sec	Yes	Stop the machine
ALA05	Probe B5 broken or disconnected	Automatic	60 sec	Yes	Stop the pump of the solar collector
ALA06	Probe B6 broken or disconnected	Automatic	60 sec	Yes	Stop the functions enabled by the outside probe
ALA07	Probe B7 broken or disconnected	Automatic	60 sec	Yes	Stop the machine
ALA08	Probe B8 broken or disconnected	Automatic	60 sec	Yes	Stop the pump of the solar collector
ALA09	Probe B9 broken or disconnected	Automatic	60 sec	Yes	If Siam compressor stops the compr.
ALA10	Probe B10 broken or disconnected	Automatic	60 sec	Yes	If there is the electronic expansion valve it stops the machine
ALA11	Probe B11 broken or disconnected	Automatic	60 sec	Yes	Stop the machine
ALA12	Probe B12 broken or disconnected	Automatic	60 sec	Yes	Stop the machine
ALB01	Position: ID3 High pressure	Manual	Immediate	Yes	Stop the machine
ALB02	High pressure of the compressor 1 from transducer	Manual	Immediate	Yes	Stop the machine
ALB03	Low pressure of the compressor/s from transducer	Automatic (par. Hc05)	At the start: 40s (par. Hc03) at regime: 10s (par. Hc04)	Yes	Stop the machine
ALC01	Position: ID2 Thermal compressor 1 or allarm inverter	Manual	Immediate	Yes	If 1 comp. enabled: stop the machine If 2 comp. enabled: stop comp.1 (if comp. 2 is available)
ALC02	Position: ID9 Thermal compressor 2	Manual	Immediate	Yes	Stop comp.2 (if comp. 1 is available)
ALC03	Alarm envelope: 0: Max.rel.compr. 1: Max.press.drain 2: Power limit 3: Max.press.suc. 4: Min.rel.compr. 5: Min.diff.pressure. 6: Min.press.drain 7: Min. press.suc. Compressor off for working out of envelope (only with compressor Siam)	Manual	60 sec (par. H1b14)	Yes	Stop the compressor
ALC04	Alarms missing start of the compressor (only with compressor Siam)	After 5 times per hour it becomes manual	60 sec (par. H1b11)	Yes	Stop the compressor
ALC05	Max.drain time (only with compressor Siam)	After 3 times per hour it becomes manual	Immediate	Yes	Stop the compressor
ALC06	Delta pressure < minimum request for the return of the compr. oil (only with compressor Siam)	Automatic	120 sec (par. H1b12)	Yes	Stop the compressor

Alarm code	Visualized message	Reset	Delay	Relay	Action
ALP01	Position: ID1 Flow switch geothermal circ. water	After 5 times per hour it becomes manual	At the start: 15s (par. Hc15) at regime: 5s (par. Hc16)	Yes	Stop the machine at maximum time reached
ALP02	Position: ID4 Thermal pumps	Manual	Immediate	Yes	Stop the machine
ALP03	Positions: ID10 Flow switch primary circuit water	After 5 times per hour it becomes manual	At the start: 15s (par. Hc12) at regime: 5s (par. Hc13)	Yes	Stop the machine at maximum time reached
ALP04	Position: ID5 Thermal pump solar circuit	Manual	Immediate	Habilitable (Gfc01)	Stop the pump of solar collector
ALR01	Position: ID7 Alarm boiler/ resistance integr. system	Automatic	Immediate	Habilitable (Gfc02)	Stop boiler/ resistance operation primary circuit integration
ALR02	Position: ID6 Thermic boiler/resistance DHW from digital input	Manual	Immediate	Settable (Gfc03)	Stop operation boiler/resistance integration DHW
ALF01	Position: ID1 Thermic fan	Manual	Immediate		Stop the machine
ALT01	Threshold reached worked hours by the compressor 1	Manual	Immediate	Settable (Gfa01)	Only signal
ALT02	Threshold reached worked hours by the compressor 2	Manual	Immediate	Settable (Gfa01)	Only signal
ALT03	Threshold reached worked hours by the geothermal pump	Manual	Immediate	Settable (Gfa01)	Only signal
ALT04	Threshold reached worked hours by primary circ. pump	Manual	Immediate	Settable (Gfa01)	Only signal
ALT05	Reached threshold worked hours pump DHW	Manual	Immediate	Settable (Gfa01)	Only signal
ALT07	Threshold reached worked hours solar pump	Manuale	Immediate	Settable (Gfa01)	Only signal
ALT08	Threshold reached worked hours outside battery fan	Manual	Immediate	Settable (Gfa01)	Only signal
ALU01	Geothermal frosting protection exchanger	Manual (par. Gfc28)	Immediate	Yes	Stop the machine
ALU02	Frosting protection primary exchanger	Manual (par. Gfc32)	Immediate	Yes	Stop the machine
ALU03	Overheating exchanger	Manual	Immediate	Yes	Stop the machine
ALW01	Threshold reached high domestic water	Automatic	60 sec	Habilitable (Gfc01)	Only signal
ALW02	Threshold reached maximum domestic temperature at solar collector	Automatic	60 sec	Yes	Only signal
ALW03	Exceeded max. time to defrosting end	Automatic	Immediate	Yes	Only signal
ALD01	Alarm EEPROM	Manual	Immediate	Yes	Stop the machine
ALD02	Probe EVD EVO broken or disconnected	Automatic	Immediate	Yes	Stop the machine
ALD03	Engine error EEV	Manual	Immediate	Yes	Stop the machine
ALD04	Low overheating (LowSH)	Manual	Immediate	Yes	Stop the machine
ALD05	Low suction temperature	Manual	Immediate	Yes	Stop the machine
ALD06	Evaporation low temperature (LOP)	Manual	Immediate	Yes	Stop the machine
ALD07	High evaporation pressure (MOP)	Manual	Immediate	Yes	Stop the machine
ALD08	High condensation temperature (HiTcond)	Manual	Immediate	Yes	Stop the machine
ALD09	Driver offline	Automatic	Immediate	Yes	Stop the machine
ALL01	Device Power+ n. 1 Offline	Automatic	30 sec	Yes	Stop the machine
ALL02	Alarms Power+ n.1 0: No error 1: Overpower 2: Overp. engine 3: Overvoltage 4: Undervoltage 5: Overtemperature 6: Undertemperature 7: Overpower HW 8: Overtemp. engine 9: Reserved 10: Error Cpu 11: Param. default 12: Undulation DC bus 13: timeout com.ser. 14: Error thermistor 15: Error Autotuning 16: Drive disabled 17: Engine phase missing 18: Broken fan 19: Engine stalling	Manual	Immediate	Yes	Stop the machine

The letter preceding the number has the following meaning

A	"AIN" Physic probes broken uPC	P	"Pumps" Pumps flow switches, pumps thermic
B	"Boh" Alarms blocking the Circuit, High-Low pressure..	Q	"Quality" HACCP, Consumptions
C	"Compressor" Thermic, envelope	R	"Remote" Various alarms from digital inputs
D	"Driver" Electronic valve	S	"Serial probe" Serial probes
E	"Expansion" Alarms uPCe	T	"Timing" Warning maintenance
F	"Fan" fan	U	"unit" Alarms blocking the unit
G	"Generic" general alarm, Clock broken, HW, Memory	V	"VFD" Alarms inverter
H	"Humidifier" humidifier	W	"Warning" generic
I	"Fancoil" alarms coming from and hydronic net	X	Defrosting
M	"MP-BUS" / Belimo	Y	Climate
O	"Offline" Offline supervisor, offline pLAN		

15.1 Alarms resolution

Alarm code	Causes	Solution proposed
ALB01	Condensation high pressure, the most of times this alarm is caused by the too high set of the water produced both in heating than in DHW. Other very frequent causes are: the wrong positioning of regulation probes (B2 and B3) compared to the flow of the unit and the insufficient water flow to plate heat condensator.	1) place the probes B2 and/or B3 at the same height as the input flow accumulation of the machine.
ALB02	See ALB01	See ALB01
ALB03	The low pressure from transducer can be connected to dynamic inside the machine. But it can also be symptom of a malfunction of the transducer or a refrigerant loss.	If the alarm is frequent 2/3 consecutive times in 4-6 hours inspect the unit with a leak detector and contact the assistance.
ALC03	Alarm envelope, the compressor is out from its field of work. In this case the reasons can be several and not listable.	We suggest at first to consider the use of the unit that can be incoherent with the work field of the unit, for example, operation DHW with outside too high temperatures. See the section "operative zone allowed" of this manual.
ALC04	The compressor can't create a minimum pressure delta in a certain interval of time, the cause can be the inertia of the system and the nearness between the temperatures of air and water	If it occurs occasionally, it's just a no serious signal permitting to the unit to keep on working.
ALP03	Flow loss in the hydraulic system, caused by air in the system, solid particles or excessive flow loss	Vent the system of all the air, regular cleaning of the system. Avoid excessive pressure loss in the hydraulic circuit, in particular avoid restrictions in the system.
ALW03	Caused by air currents cooling the coil finned during the defrosting procedure	Study a different positioning of the machine or block the wind addressed to the unit.
ALD04	Alarm which depends on the dynamics inside the machine	Contact the assistance
ALD06	Alarm which depends on the dynamics inside the machine	Inspect the unit with leak detector and contact the assistance
ALD07	Alarm which depends on the dynamics inside the machine	Contact the assistance
ALL01	Missing communication between inverter and electronic board caused by slight power surges and current or by electromagnetic fields disturbing the network	Check the counter powering the machine, avoid to overload it, check the domestic line, avoid electromagnetic fields nearby
ALL02	Missing communication between inverter and electronic board caused by strong power surges and current or electromagnetic fields disturbing the network	Check the counter powering the machine, avoid to overload it, check the domestic line, avoid electromagnetic fields nearby. The contact the assistance.

15.2 Notifications

Notification	causes
Heat Transfer Limited	It occurs when the difference between the value of the B7 and B2 probes in the case of heating operation, or the difference between B7 and B3 probes in the case of DHW production, is excessive.
Power limit temperature	It is activated if the heat pump is producing water less than 6 ° or more than 58 °. The compressor is moves to a minimum speed to avoid generating an error.
Irregular waterflow	Since the heat pump was powered, at least once a problema of flow occurred. After five of these notificatios, the next one is a flow error.

16 Performances

	TECHNICAL DATA Air-Air Heat pump with internal gih efficiency unit	U. M.	Nom.	Max
Heating mode (Air7°C-Ambient 20°C)	Heating capacity	kW.	26,5	39,0
	COP		5,4	4,34
Cooling mode (Air35°C-Ambient 27°C)	Cooling capacity	kW.	27,0	39,0
	EER		5,5	4,02
Power supply	Power supply	V/np/Hz	400/3/50	
	Maximum input power	kW	13,3	
	Maximum current	A	30	
Working range	Heating	Min ~ Max °C	-33°C ~ 35°C	
	Cooling	Min ~ Max °C	-10°C ~ 50°C	
Compressor	Type		Scroll	
	Number		1	
	Typology		Inverter Vapour Injection	
	Power supply	V-np-Hz	400-3-50	
	Oil quantity (PVE)	kg	2,2	
	Oil version		FV50S	
External fan	Model		EBMPAPST	
	Type		Inverter BLDC	
	Numer		1	
	Nominal diameter	mm	910	
	Maximum input power	kW	0.625	
	Maximum current	A	1.1	
	Max. speed	rps	610	
	Max. air flow	m3/h	15000	
Internal fan	Model		EBMPAPST	
	Type		Inverter BLDC	
	Numer		1	
	Nominal diameter	mm	800	
	Maximum input power	kW	0.44	
	Maximum current	A	1.9	
	Max. speed	rps	600	
	Max. air flow	m3/h	6000	
Noise	Acoustic pressure (at 5 meter)	Max dB(A)	55	
	Acoustic power (35°C external air)	Max dB(A)	69	
Dimensions	External unit	H x L x D mm	1256x1791x670	
	Internal unit	H x L x D mm	1080X1263X774	
Refrigerant	Type		R410A	
	Quantity	kg	11	
Regolation	Main valve		EEV	
	Injection valve		EEV	
Refrigerant connections	Gas	∅ mm (inch)	22 (7/8")	
	Liquid	∅ mm (inch)	12 (1/2")	
Unit n°			1	
Internal connectable unit n°			1	
External heat xchanger	Number of ranks	nr.	3	
	Fins distance	mm	2,5	
	Coating		Hydrophobic	
Internal heat exchanger	Number of ranks	nr.	3	
	Fins distance	mm	1,6	

17 Declaration of conformity

17.1 Declaration of conformity KITA AIR



Dichiarazione di conformità CE

EC Declaration of Conformity

EG Konformitätserklärung

La sottoscritta

Templari S.r.l.

The undersigned

Via Pitagora, 20/A - 35030 Rubano (PD) - Italy

Die Firma

P. IVA 04128520287

conferma che gli apparecchi qui di seguito indicati rispondono alle seguenti direttive CE applicabili in materia. Ogni modifica degli apparecchi rende la presente dichiarazione non valida.

hereby certifies that the following device comply with the applicable EU directives. This certification loses its validity if the device are modified.

erklärt in alleiniger Verantwortung, dass das nachfolgend erwähnte Produkt.

Denominazione: Pompe di calore
Designation: Heat pumps
Produkt: Wärmepumpe

Modelli Kita L/L Split L42/L42 Split L66/L66 Split/L66 Air
Types: Kita L/L Split L42/L42 Split L66/L66 Split/L66 Air
Typ: Kita L/L Split L42/L42 Split L66/L66 Split/L66 Air

Direttive CE

Direttiva 97/23/CE & 2014/68/EU
Direttiva 2004/108/CE

EC Directives

Directive 97/23/CE & 2014/68/EU
Directive 2004/108/CE

EG-Anforderungen

Richtlinie 97/23/CE & 2014/68/EU
Richtlinie 2004/108/EC

Norme applicate

Standard Armonizzati EN 55014-1:2006+A1 :2009
EN 55014-2:1997+A:2001+A2:2008:
EN 61000-3-2:2006+A1, A2:2009;
EN 61000-4-2:2008; 61000-4-4:2008;
EN 61000-4-5:2008;
EN 61000-4 6:2008;

Applied standard

Angewandte Norm

Conformità PED assieme con Modulo A1 per categoria II, n.1936 dal TUV Rheinland Italia S.r.l. via Mattei, 3 20010 Pogliano Milanese (MI)

PED compliance, A1 module for PED cat. II from TUV n. 1936 from TUV Rheinland Italia S.r.l. via Mattei, 3 20010 Pogliano Milanese (MI)

DGRL Konformität mit Modul A1 fl.ir Kategorie II, n.1936 von TUV Rheinland Italia S.r.l. via Mattei, 3 20010 Pogliano Milanese (MI)

Componente/Componenti Komponente	Categoria/Cat ory/ Kategorie	Modulo di conformità/ Form of Conformity/ Form von Konformität	Ente/Entity/Wesen
Assieme/ Assembly/Montage	II	Modul A2	1936
Ricevitori di liquido/Liquid receiver/ Flüssigkeitssammler	II	Modul A1	0035
Pressostato/Pressure switch/ Druckschalter	IV	Modul H1+B	0035
Valvola di sicurezza/Safety valve/ Ventil	IV	Modul H1+B	0036

Altre direttive

-Direttiva Bassa Tensione 2006/95/ CE;
-Bassa tensione/Direttiva europea e recepimento italiano Dir. 73/23/CEE;
-Direttiva Macchine 2006/42/CE;

Other directives

-Low voltage directive 2006/95/CE
-73/23/CEE devices directive
-2006/42/CE

Weitere Richtlinien

-Richtlinie 2006/95/EG
(Niederspannungsrichtlinie);
-73/23/CEE;
-Richtlinie 2006/42/EG
(Maschinenrichtlinie)

Templari S.r.l.
www.templari.com



via Pitagora, 20A - 35030 Rubano (PD) - Italia
Tel. +39 049 8597400 | +39 049 5225929
www.templari.com | info@templari.com

