

Installation and user manual  
(Translation of original  
instructions)

EN



**innova**

N273110A - Rev.13 - 06/2022

# Filomuro

SW

---

*First of all, we would like to thank you for having chosen a device of our production.*

*We are sure you will be happy with it because it represents the state of the art in the technology of home air conditioning.*

*By following the suggestions contained in this manual, the product that you have purchased will operate without problems giving you optimum room temperatures with minimum energy costs.*

INNOVA S.r.l.

## Conformity

This unit complies with the European directives:

- Low voltage 2014/35 / EU;
- Electromagnetic compatibility 2014/30 / EU;

## Markings



# TABLE OF CONTENTS

<b>1</b>	<b>General information</b>	<b><u>p. 6</u></b>
<b>1.1</b>	<b>About the manual</b>	<b><u>p. 6</u></b>
1.1.1	Editorial pictograms	<u>p. 6</u>
1.1.2	Pictograms on the product	<u>p. 6</u>
1.1.3	Recipients	<u>p. 6</u>
1.1.4	Manual organisation	<u>p. 7</u>
<b>1.2</b>	<b>General warnings</b>	<b><u>p. 7</u></b>
<b>1.3</b>	<b>Basic rules of security</b>	<b><u>p. 7</u></b>
<b>1.4</b>	<b>Disposal</b>	<b><u>p. 8</u></b>
<b>2</b>	<b>Product presentation</b>	<b><u>p. 9</u></b>
<b>2.1</b>	<b>Destination of use</b>	<b><u>p. 9</u></b>
<b>2.2</b>	<b>Description of the appliance</b>	<b><u>p. 9</u></b>
<b>2.3</b>	<b>Compatible accessories</b>	<b><u>p. 10</u></b>
<b>3</b>	<b>Installation</b>	<b><u>p. 11</u></b>
<b>3.1</b>	<b>Preliminary warnings</b>	<b><u>p. 11</u></b>
<b>3.2</b>	<b>Reception</b>	<b><u>p. 11</u></b>
3.2.1	Preliminary warnings	<u>p. 11</u>
3.2.2	Package description	<u>p. 11</u>
<b>3.3</b>	<b>Dimensions and weights with packaging</b>	<b><u>p. 11</u></b>
<b>3.4</b>	<b>Installation site</b>	<b><u>p. 12</u></b>
3.4.1	Preliminary warnings	<u>p. 12</u>
<b>3.5</b>	<b>Installation mode</b>	<b><u>p. 12</u></b>
<b>3.6</b>	<b>Installation minimum distances</b>	<b><u>p. 12</u></b>
<b>3.7</b>	<b>Positioning</b>	<b><u>p. 13</u></b>
3.7.1	Device preparation	<u>p. 13</u>
3.7.2	Installation arrangement	<u>p. 14</u>
3.7.3	Positioning	<u>p. 14</u>
<b>3.8</b>	<b>Hydraulic connections</b>	<b><u>p. 16</u></b>
3.8.1	Position and dimensions	<u>p. 16</u>
3.8.2	Connection to the system	<u>p. 16</u>
3.8.3	Hydraulic accessories	<u>p. 16</u>
3.8.4	Connection with 2-way manual valve (I20686)	<u>p. 17</u>
3.8.5	Connection with 2-way valve and thermoelectric actuator (V20687)	<u>p. 17</u>
3.8.6	Connection with 3-way diverting valve unit with thermoelectric actuator (V30688)	<u>p. 18</u>
<b>3.9</b>	<b>Condensation drain preparation</b>	<b><u>p. 18</u></b>
3.9.1	Preliminary warnings	<u>p. 18</u>
3.9.2	Positioning	<u>p. 19</u>
3.9.3	Check	<u>p. 19</u>
<b>3.10</b>	<b>Filling the system</b>	<b><u>p. 19</u></b>
<b>3.11</b>	<b>Electric connections</b>	<b><u>p. 20</u></b>
3.11.1	Access to the terminal block	<u>p. 20</u>

<b>3.12 Diagrams and configurations electrical controls . . . . .</b>	<b><u>p. 21</u></b>
3.12.1 Touchpad and remote control (code suffix-0Q00) . . . . .	<u>p. 21</u>
3.12.2 Remote control EEA649 - EEB649 / EFA649 - EFB649 (code suffix-0P00) . . . . .	<u>p. 22</u>
3.12.3 Setup menu EEA649 - EEB649 / EFA649 - EFB649 . . . . .	<u>p. 24</u>
3.12.4 Remote control with fixed speed (code suffix-0T00) . . . . .	<u>p. 26</u>
3.12.5 Remote control with modulating speed (code suffix-0V00) . . . . .	<u>p. 28</u>

## **4 Unit with touchpad and remote control . . . . . p. 30**

<b>4.1 Interface . . . . .</b>	<b><u>p. 30</u></b>
4.1.1 Description . . . . .	<u>p. 30</u>
4.1.2 Display . . . . .	<u>p. 30</u>
4.1.3 Remote control. . . . .	<u>p. 31</u>
4.1.4 General start-up . . . . .	<u>p. 31</u>
<b>4.2 Main functions. . . . .</b>	<b><u>p. 32</u></b>
4.2.1 Set room temperature . . . . .	<u>p. 32</u>
4.2.2 Cooling only mode . . . . .	<u>p. 32</u>
4.2.3 Ventilation only mode . . . . .	<u>p. 32</u>
4.2.4 Set the speed . . . . .	<u>p. 32</u>
4.2.5 Heating only mode . . . . .	<u>p. 32</u>
4.2.6 Night function . . . . .	<u>p. 32</u>
4.2.7 Set the direction of the air flow . . . . .	<u>p. 32</u>
4.2.8 Setting the Timer function . . . . .	<u>p. 32</u>
4.2.9 Set the key lock. . . . .	<u>p. 33</u>
4.2.10 Deactivate-put in stand-by the control . . . . .	<u>p. 33</u>
<b>4.3 Warnings . . . . .</b>	<b><u>p. 33</u></b>
4.3.1 Visualization of alarms on display . . . . .	<u>p. 33</u>
4.3.2 Operating the unit if the remote control is not available . . . . .	<u>p. 33</u>
4.3.3 Troubleshooting . . . . .	<u>p. 33</u>

## **5 Wall mounted remote control EEA649 - EEB649 / EFA649 - EFB649 . . . . . p. 34**

<b>5.1 Installation. . . . .</b>	<b><u>p. 34</u></b>
5.1.1 Description . . . . .	<u>p. 34</u>
5.1.2 Mounting . . . . .	<u>p. 34</u>
<b>5.2 Electric connections . . . . .</b>	<b><u>p. 35</u></b>
5.2.1 Connection diagram . . . . .	<u>p. 35</u>
5.2.2 Terminal block position . . . . .	<u>p. 35</u>
5.2.3 Connection to the PCB . . . . .	<u>p. 36</u>
5.2.4 CP presence contact input connection. . . . .	<u>p. 36</u>
5.2.5 RS485 Serial Connection. . . . .	<u>p. 36</u>
<b>5.3 Interface . . . . .</b>	<b><u>p. 36</u></b>
5.3.1 Description . . . . .	<u>p. 36</u>
5.3.2 Display . . . . .	<u>p. 36</u>
5.3.3 Keys functions . . . . .	<u>p. 37</u>
5.3.4 General start-up . . . . .	<u>p. 37</u>
<b>5.4 Main functions. . . . .</b>	<b><u>p. 37</u></b>
5.4.1 Operating mode set-up . . . . .	<u>p. 37</u>
5.4.2 Put in stand-by the control. . . . .	<u>p. 37</u>
5.4.3 Set room temperature . . . . .	<u>p. 37</u>
5.4.4 Automatic operation . . . . .	<u>p. 38</u>
5.4.5 Silent operation . . . . .	<u>p. 38</u>

5.4.6	Night function . . . . .	<u>p. 38</u>
5.4.7	Maximum ventilation speed . . . . .	<u>p. 38</u>
5.4.8	Set the key lock. . . . .	<u>p. 38</u>
5.4.9	Brightness reduction . . . . .	<u>p. 38</u>
5.4.10	Deactivation . . . . .	<u>p. 38</u>
5.4.11	Room temperature probe offset adjustment . . . . .	<u>p. 38</u>
<b>5.5</b>	<b>Warnings . . . . .</b>	<b><u>p. 38</u></b>
5.5.1	Long period shut-down . . . . .	<u>p. 38</u>
5.5.2	Error signals . . . . .	<u>p. 38</u>
<b>6</b>	<b>Wall-mounted control B3V151 - B3V152 . . . . .</b>	<b><u>p. 39</u></b>
<b>6.1</b>	<b>Electric connections . . . . .</b>	<b><u>p. 39</u></b>
6.1.1	Connection diagram . . . . .	<u>p. 39</u>
<b>7</b>	<b>Maintenance . . . . .</b>	<b><u>p. 40</u></b>
<b>7.1</b>	<b>Routine maintenance. . . . .</b>	<b><u>p. 40</u></b>
<b>7.2</b>	<b>Six-monthly operations . . . . .</b>	<b><u>p. 40</u></b>
7.2.1	External cleaning . . . . .	<u>p. 40</u>
7.2.2	Air intake filter cleaning . . . . .	<u>p. 40</u>
<b>7.3</b>	<b>Suggestions for energy saving . . . . .</b>	<b><u>p. 41</u></b>
<b>8</b>	<b>Troubleshooting . . . . .</b>	<b><u>p. 42</u></b>
<b>8.1</b>	<b>Preliminary warnings. . . . .</b>	<b><u>p. 42</u></b>
<b>8.2</b>	<b>Troubleshooting table . . . . .</b>	<b><u>p. 42</u></b>
<b>9</b>	<b>Technical information. . . . .</b>	<b><u>p. 43</u></b>
<b>9.1</b>	<b>Technical data . . . . .</b>	<b><u>p. 43</u></b>
9.1.1	2 pipes . . . . .	<u>p. 43</u>
<b>9.2</b>	<b>Dimensions . . . . .</b>	<b><u>p. 44</u></b>
9.2.1	2 pipes . . . . .	<u>p. 44</u>

# GENERAL INFORMATION

## 1.1 About the manual

This manual was written to provide all the explanations for the correct management of the appliance.

- ⚠ This instruction manual forms an integral part of the device and therefore must be carefully preserved and must ALWAYS travel with it, even if you transfer the device to another owner or relocate it to other premises. If the manual gets damaged or lost, download a copy from the website.
- ⚠ Read this manual carefully before proceeding with any operation and follow the instructions in the individual chapters.
- ⚠ The manufacturer is not responsible for damages to persons or property caused by failure to follow the instructions in this manual.
- ⚠ This document is restricted in use to the terms of the law and may not be copied or transferred to third parties without the express authorization of the manufacturer.

### 1.1.1 Editorial pictograms

The pictograms in the next chapter provide the necessary information for correct, safe use of the machine in a rapid, unmistakable way.

#### Related to security

- ⚠ **High risk warning (bold text)**
  - The operation described above presents a risk of serious physical injury, fatality, major damage to the appliance and/or to the environment if not carried out in compliance with safety regulations.
- ⚠ Low risk warning (plain text)
  - The operation described above presents a risk of minor physical injury or minor damage to the appliance and/or to the environment if not carried out in compliance with safety regulations.
- ⊘ Prohibition (plain text)
  - Refers to prohibited actions.
- i **Important information (bold text)**
  - This indicates important information that must be taken into account during the operations.

#### In the texts

- procedures
- lists

#### In the control panels

- actions required
- Expected responses following an action.*

- lists

#### In the figures

- 1 The numbers indicate the individual components.
- A The capital letters indicate component assemblies.
- ① The white numbers in black marks indicate a series of actions to be carried out in sequence.
- Ⓐ The black letter in white identifies an image when there are several images in the same figure.

### 1.1.2 Pictograms on the product

Symbols are used in some parts of the appliance:

#### Related to security

- ⚠ **Caution: electrical danger**
  - The concerned personnel is informed to the presence of electricity and the risk of suffering an electric shock.

### 1.1.3 Recipients

#### User

Non-expert person capable of operating the product in safe conditions for people, for the product itself and the environment, interpreting an elementary diagnostic of faults and abnormal operating conditions, carrying out simple adjustment, checking and maintenance operations.

#### Installer

Expert person qualified to position and connect (hydraulically, electrically, etc.) the unit to the plant; this person is responsible for handling and correct installation according to the instructions provided in this manual and the national standards currently in force.

To work on the refrigeration circuit, the installer must comply with the provisions of Regulation 303/2008/EC which defines, in accordance with Directive 842/2006/EC, the requirements for companies and personnel with regard to fixed refrigeration, air conditioning and heat pump equipment containing certain fluorinated greenhouse gases (F-gas licence).

#### Technical Service Centre

Expert and qualified person authorised directly by the manufacturer to carry out all routine and supplementary maintenance operations, as well as every adjustment, check, repair and replacement of parts necessary during the life of the unit itself.

Service personnel must comply with the provisions of Regulation 303/2008/EC which defines, in accordance with Directive 842/2006/EC, the requirements for companies and personnel with regard to fixed refrigeration, air conditioning and heat pump equipment containing certain fluorinated greenhouse gases (F-gas licence).

### 1.1.4 Manual organisation

The manual is divided into sections each dedicated to one or more target groups.

#### General information

It addresses all recipients.

It contains general information and important warnings that should be known before installing and using the appliance.

#### Product presentation

It addresses all recipients.

It contains the information to identify the product, its components, compatible accessories and destination of use.

#### Installation

It is addressed exclusively to the installer.

It contains specific warnings and all the information necessary for positioning, mounting and connecting the appliance.

#### Commissioning, maintenance and troubleshooting

They are addressed exclusively to the Technical Assistance Centre.

It contains specific warnings useful information for the most common commissioning and routine maintenance.

#### Technical information

It addresses all recipients.

It contains detailed technical information about the appliance.

## 1.2 General warnings

- ⚠ Specific warnings are given in each chapter of the document and must be read before starting operations.
- ⚠ All personnel involved must be aware of the operations and dangers that may arise when beginning all unit installation operations.
- ⚠ Installation performed outside the warnings provided in this manual and use of the appliance outside the prescribed temperature limits will invalidate the warranty.
- ⚠ The installation and maintenance of climate control equipment could be dangerous because there is live electrical components inside the appliances. The installation, initial start-up and subsequent maintenance phases must be carried out exclusively by authorised and qualified personnel (see first start-up request form enclosed with the appliance).
- ⚠ Any contractual or extra-contractual liability for damage caused to persons, animals or property, due to installation, adjustment and maintenance errors or improper use is excluded. All uses not expressly indicated in this manual are not permitted.
- ⚠ Only qualified installer companies are authorised to install the device. After having completed installation, the installer will issue a declaration of conformity to the plant manager, as required by the applicable standards and the guidelines provided by contractor's instruction manual supplied with the device.
- ⚠ First start-up and repair or maintenance operations must be carried out by the Technical Assistance Centre or by qualified personnel following the provisions of this manual.
- ⚠ Do not modify or tamper with the appliance as this can lead to dangerous situations.
- ⚠ Use suitable accident-prevention clothing and equipment during installation and/or maintenance operations. The manufacturer is not liable for the non-observance of the current safety and accident prevention regulations.
- ⚠ In the event of liquid or oil leaks, set the master switch of the plant to "off" and close the water taps. Call the authorised Technical Assistance Centre or professionally qualified personnel as soon as possible and do not work on the appliance yourself.
- ⚠ In case of replacement of parts, use only original parts.
- ⚠ The manufacturer reserves the right to make changes to its models at any time to improve its product, without prejudice to the essential characteristics described in this manual. The manufacturer is not obliged to add such modifications to machines previously manufactured, already delivered or under construction.

## 1.3 Basic rules of security

Please keep in mind that the use of products powered by electricity and water call for operators to comply with certain essential safety rules:

- ⊖ The use of the appliance to children and unassisted disabled persons is prohibited.
- ⊖ It is forbidden to touch the device with wet or damp body parts.
- ⊖ It is forbidden to carry out any operation before disconnecting the appliance from the power supply by setting the plant master switch to "off".
- ⊖ It is forbidden to modify the safety or adjustment devices or adjust without authorization and indications of the manufacturer.
- ⊖ It is forbidden to pull, unplug or twist the device's electric cables, even if it is disconnected from the mains.
- ⊖ It is forbidden to introduce objects and substances through the air inlet and outlet grilles.
- ⊖ It is forbidden to open the access doors of the device's internal parts without first having set main switch of the system to "off".

- ⊖ It is forbidden to dispose of, or leave in the reach of children, the packaging materials which could become a source of danger.

## 1.4 Disposal

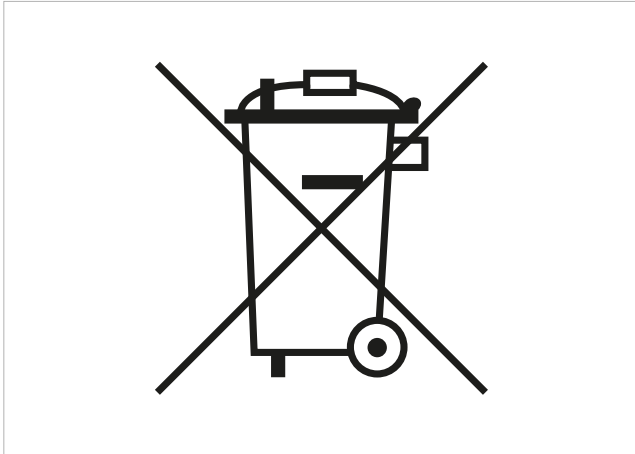

The symbol on the product or its packaging indicates that the product must not be treated as normal household waste, but must be taken to the appropriate collection point for the recycling of electrical and electronic equipment.

Proper disposal of this product avoids harm to humans and the environment and promotes the reuse of valuable raw materials.

For more detailed information about the recycling of this product, contact your local city office, your household waste disposal service or the shop where you purchased the product.

Illegal disposal of the product by the user involves the application of the administrative sanctions provided for by the regulations in force.

This provision is only valid in the EU Member States.

- ⚠ Avoid disassembling the unit yourself.
- ⚠ This unit contains fluorinated greenhouse gases covered by the Kyoto Protocol. Maintenance and disposal operations must be carried out by qualified personnel only.
- ⚠ **Contact an authorised Technical Assistance Centre to disassemble the appliance.**



## PRODUCT PRESENTATION

### 2.1 Destination of use

These appliances have been designed for conditioning and/or heating rooms and they must be destined solely for

this purpose, in accordance with their performance characteristics.















### 2.2 Description of the appliance

**Filomuro** fancoils range are designed for wall installation. The device are made in three different performance levels and size, all for two-pipe configuration.

**Filomuro** fancoils range are available into four configurations based on control mode:

- with touchpad and remote control
- for connection with remote control at modulating speed
- for connection with remote control at fixed speed
- for 0-10 V connection at modulating speed

## 2.3 Compatible accessories

	Accessory description	Combinable products	Code
<b>Wall-mounted control panels</b>			
<b>Control panels</b>			
	SMART TOUCH wall mounted control panel with thermostat and room temperature and relative humidity probe. Colour black	All	EEA649II
	SMART TOUCH wall mounted control panel with thermostat and room temperature and relative humidity probe. Colour white	All	EEB649II
	SMART TOUCH wall mounted control panel with thermostat and room temperature and relative humidity probe with integrated WiFi module, InnovAPP. Colour black	All	EFA649II
	SMART TOUCH wall mounted control panel with thermostat and room temperature and relative humidity probe with integrated WiFi module, InnovAPP. Colour white	All	EFB649II
<b>WALL MOUNTED STANDARD FANCOIL CONTROLS</b>			
<b>Control panels</b>			
	Wall mounted control with thermostat, summer/winter and speed selectors	All	B3V151II
	Wall mounted control with thermostat, summer/winter and speed selectors	All	B3V152II
<b>Network controls</b>			
<b>Butler</b>			
	BUTLER: codes, accessories and price list in relevant section	All	
<b>Controls and circuit board</b>			
<b>(motor connection cable for LEFT hydraulic connections)</b>			
	Hydraulic connection reversal kit	Filomuro	BB0646II (1)
<b>Hydraulic kit</b>			
<b>HYDRAULIC KIT</b>			
	Couple of EUROKONUS adapters for 1/2" female connection (male fittings)	All	AI0200II
	Couple of EUROKONUS adapters for 3/4" female connection (male fittings)	All	AI0201II
	90° bended EUROKONUS connector	All	AI0203II
	Distancer kit ( 1 piece)	All	AI0501II
	Adaptors for flat ring	All	AI0612II
	2 way valve group with manual closure	Filomuro XL	I20205II (1)
		Filomuro	I20686II (1)
	2 way valve group (water inlet valve, shut off valve and electro thermal motor)	Filomuro XL	V20139II (1)
	2 way valve group (water inlet valve, shut off valve and electro thermal motor)	Filomuro	V20687II (1)
	3 way valve group (with inlet 3 way valve, shut off valve, and electro thermal motor)	Filomuro	V30688II (1)
		Filomuro XL	V30718II (1)

1. Accessories can be installed and tested at the factory

## INSTALLATION

### 3.1 Preliminary warnings

- ⚠ **For detailed information on the products, refer to chapter "Technical information" p. 43**
- ⚠ The installation must be carried out by the installer. There is a risk of water leakage, electric shock or fire if the installation is not performed correctly.
- ⚠ During the installation, it is necessary to observe the precautions mentioned in this manual, and on the labels placed inside the equipment, as well as to adopt any precaution suggested by common sense and by the Safety Regulations in force in the place of installation.
- ⚠ Be sure to use the supplied or specified installation parts. Use of other parts may cause the unit to come to lose, water leakage, electrical shock, or fire.
- ⚠ Failure to apply the indicated rules may cause malfunctions of the appliances and relieves the manufacturer from any warranty and from any damage caused to persons, animals or property.

### 3.2 Reception

#### 3.2.1 Preliminary warnings

- ⚠ Upon receipt of the package check that it is not damaged, otherwise accept the goods with reserve, producing photographic evidence of any damage.
- ⚠ In the event of damage, notify the shipper within 3 days of receipt of any damage by registered mail with return receipt, submitting photographic evidence. Similar information should be sent by fax to the manufacturer (jurisdiction will be at the Court Trento for any dispute).
- ⚠ No notice of damage will be accepted after 3 days from delivery.
- ⚠ Unpack and check the contents against the packing list.

#### 3.2.2 Package description

The packaging is made of suitable material and carried out by experienced personnel. All units are checked and tested and are delivered complete and in perfect conditions. The appliance is shipped in standard packaging consisting of a cardboard sleeve and a set of expanded polystyrene protectors.

### 3.3 Dimensions and weights with packaging

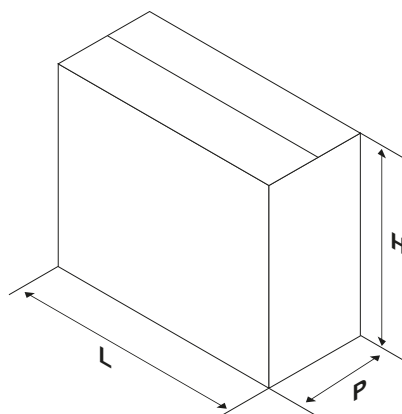

Models		m.u.	Filomuro		
			400	600	800
<b>Dimensions and weight for shipping</b>					
Total width		mm	1020	1220	1320
Total height		mm	490	490	490
Total depth		mm	213	213	213
Weight		kg	15,0	17,0	20,0

### 3.4 Installation site

Position of device must be established by the system designer or other qualified professional and must take into account both technical requirements and any local laws in force.

**The Filomuro fancoil has to be installed only in high position on the wall, with a maximum height of 2,2 m (except for use in cooling only).**

#### 3.4.1 Preliminary warnings

- ⚠️ Avoid installing the unit near:
  - obstacles or barriers that cause recirculation of the exhaust air
  - narrow places where the sound level of the appliance can be enhanced by reverberations or resonances
  - environments with the presence of flammable or explosive gases
  - very humid environments (laundries, greenhouses, etc.)
  - environments with aggressive atmospheres
  - solar radiation and proximity to heat sources
  - rooms subject to high frequencies
- ⚠️ Do not install over heat sources.
- ⚠️ Make sure that:

- the installation site of the unit must be chosen with the utmost care to guarantee adequate protection from shocks and consequent damage
- the wall is able to support the weight of the appliance
- the wall section does not feature building supporting elements, pipes or power lines
- the wall surface is perfectly levelled
- there are no obstacles to the free circulation of air
- the appliance must be installed in a position where it can be easily serviced
- the safety distances between the units and other appliances or structures are scrupulously respected so that the air entering and leaving the fans is free to circulate
- ⚠️ If the appliance is installed incompletely or on an inappropriate base, it could cause damage to persons or property if it should detach from its base.
- ⚠️ The unit should not be installed in a position where the air flow is aimed directly at the people nearby.
- ⚠️ Provide the following:
  - a nearby drain for the outflow of condensate
  - a compliant power supply nearby
  - fixing elements suitable for the type of support

### 3.5 Installation mode

The assembly steps described below and their drawings refer to a version of the machine with connections on the right side.

- ⚠️ For ideal installation and performance levels, carefully follow the instructions in the manual.

- ⚠️ Failure to do so may cause system malfunctions and automatically voids the warranty, and relieves the constructor of any harm caused to person, animals or property.

### 3.6 Installation minimum distances

The clearance zones for the installation and maintenance of the appliance are shown in the figure. Established spaces are necessary to avoid barriers to airflow and allow for normal cleaning and maintenance.

- ⚠️ Make sure that there is sufficient space to allow the panels to be removed for routine and supplementary maintenance operations.

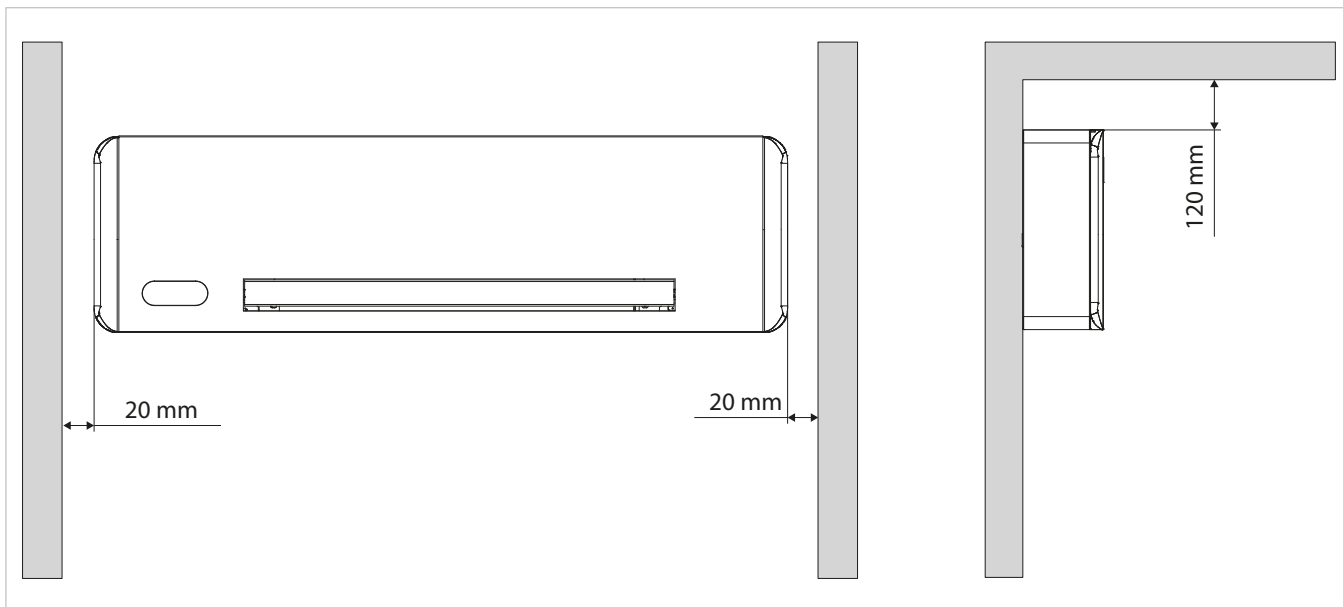

### 3.7 Positioning

The Filomuro fancoil has to be installed only in high position on the wall, with a maximum height of 2,2 m (except for use in cooling only).

The units are supplied with a paper template for marking the holes necessary for installation.

**⚠** Hold the template in the correct position with tape.

#### 3.7.1 Device preparation

Before proceeding with the installation, it is necessary to remove some elements from the appliance.

#### Remove the filter

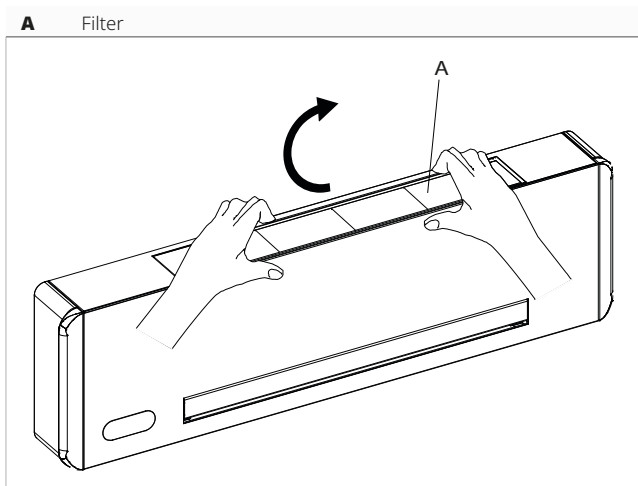

- lift the filter slightly
- rotate until the complete exit from the housing

- A** Filter  
**B** Extraction direction

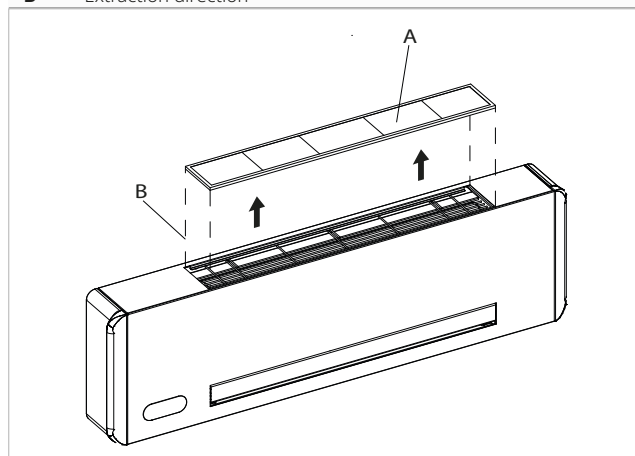

- remove the filter

#### Removal of the aesthetic front panel

- A** side panels  
**B** aesthetic front panel

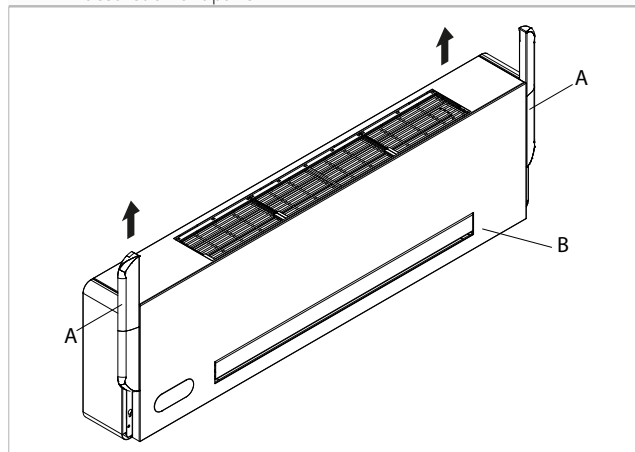

- Remove the side panels by unthreading them upwards

- A** fixing screws
- B** aesthetic front panel

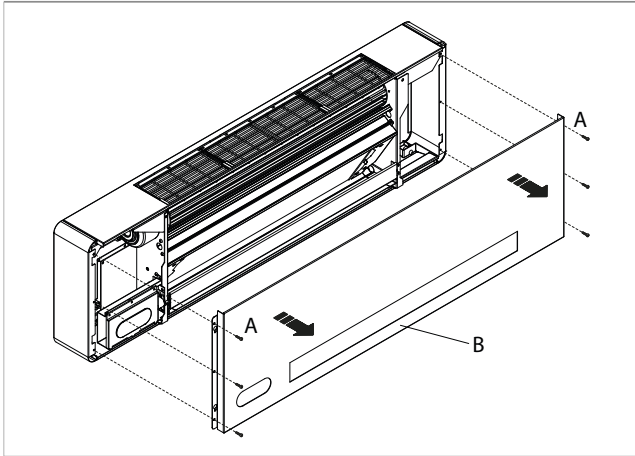

- unscrew the fixing screw
- remove the aesthetic front panel

### Remove the side panels

- A** Side panels
- B** Upper screws
- C** Left side screws

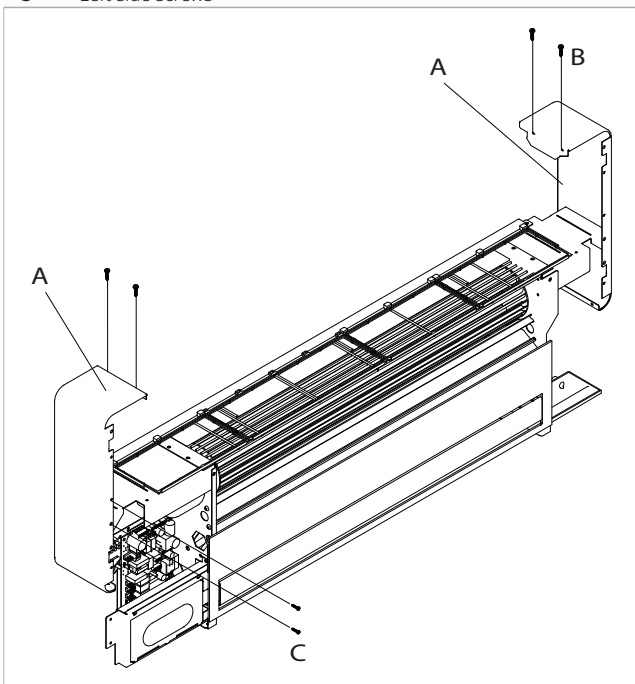

- unscrew the fixing screw
- remove the side panels

### 3.7.2 Installation arrangement

To install the appliance, use a recessed box to contain the connections.

- ⚠ If the appliance is installed later, leave the connecting pipes plentiful so as not to make joints.

- A** built-in cistern
- B** connecting water pipelines
- C** condensation drainage pipe

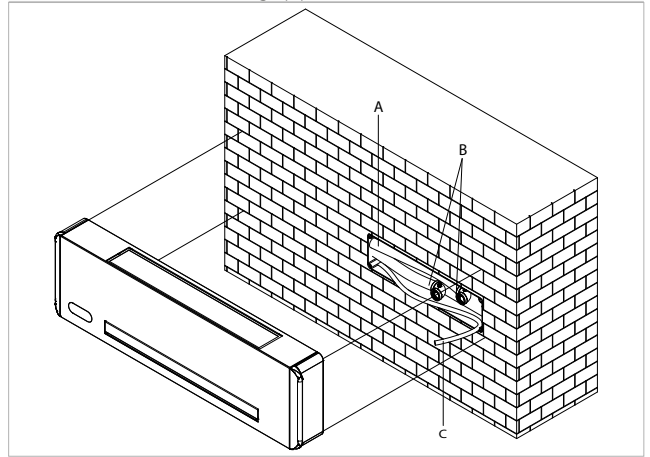

### 3.7.3 Positioning

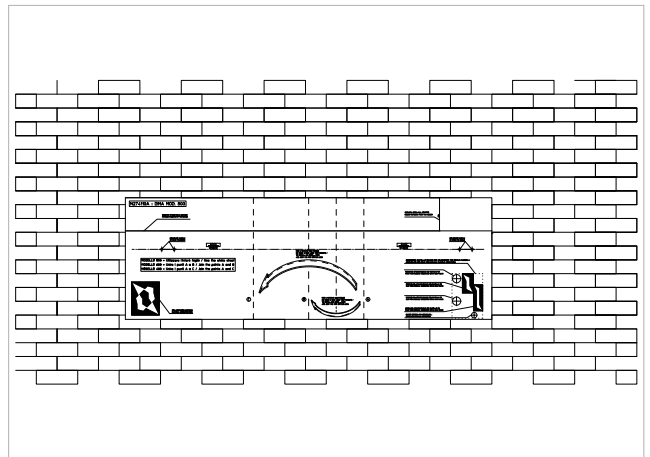

- use the paper template supplied with the device
- trace the position of the fixing brackets
- drill holes in the wall

- ⚠ Make sure that the support wall is suitable for weight of the appliance.
- ⚠ Make sure that the wall is not crossed by pipelines, load-bearing construction elements or power lines.

- A** dowels
- B** bracket

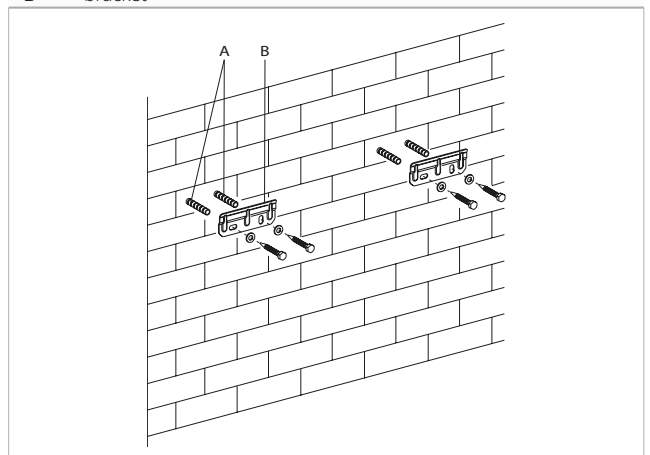

- insert the expansion plugs

- position the support brackets
- partially screw the screws

⚠ Do not fully fix the screws so that you can adjust the position of the appliance.

⚠ Use expansion plugs suitable for the chosen support wall.

⚠ The images refer to a version of the appliance with the connection on the right. If the appliance has the connection on the left side, the operation must be adapted to the position of the attacks.

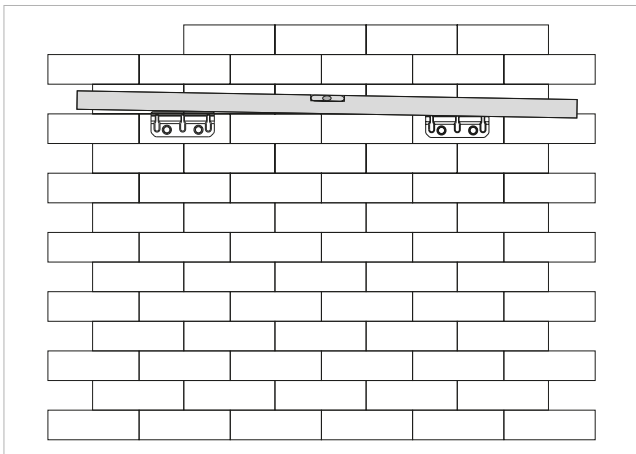

- use a leveler
- check the inclination towards the attachment side
- fix the screws

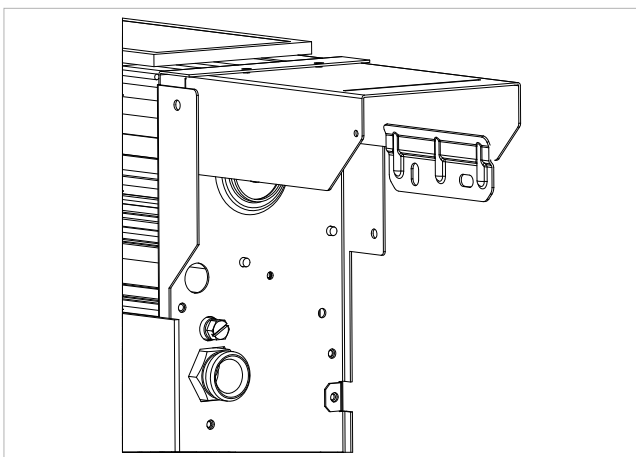

- assemble the unit
- check right attachment to the bracket

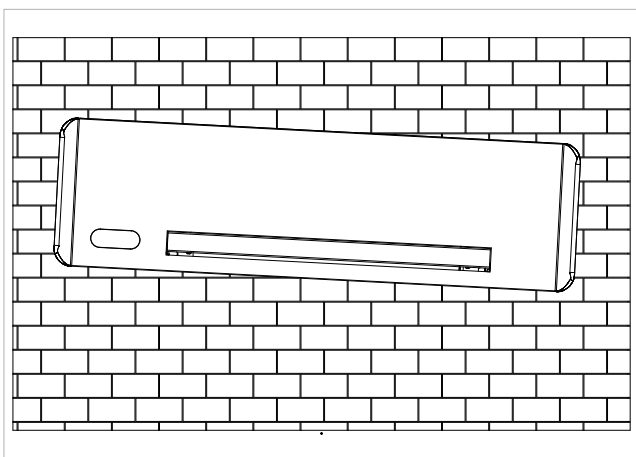

- check the inclination towards the attachment side

⚠ The inclination must not exceed an angle of 1 °.

### 3.8 Hydraulic connections

The engineer is responsible for choosing the right water lines and their size, in accordance with good installation practices and the applicable law.

**⚠** Keep in mind that undersized pipelines lead to poor system operation and/or a loss of thermal and cooling performance.

#### 3.8.1 Position and dimensions

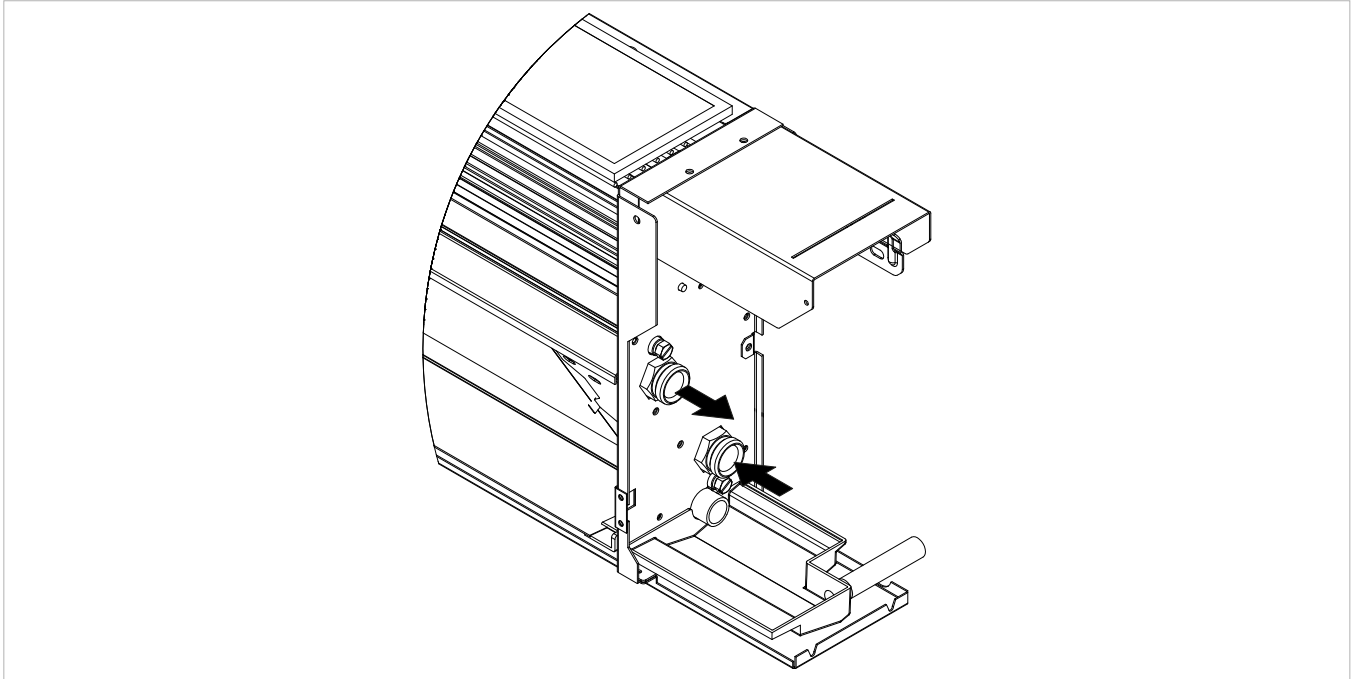

Models	m.u.	400	600	800
Pipelines minimum diameter	mm	14	16	18

#### 3.8.2 Connection to the system

To make the connections:

- hydraulic lines positioning
- use the "wrench against wrench" method
- tighten the connections
- check for leaks
- coat the connections with insulating material

**⚠** The hydraulic lines and fittings must be thermally insulated.

**⚠** Avoid partial insulation of the pipes.

**⚠** Avoid over-tightening the pipes to avoid damage to the insulation.

**⚠** Carefully check that the insulation is tight, in order to prevent the making and dripping of condensate.

#### 3.8.3 Hydraulic accessories

Normally, unit comes without any shut-off valve. In other case, depending of the request, the unit can be supplied with valves already assembled or supplied separately to be mounted during installation.

**⚠** The 2-way and 3-way motorized valves are mandatory for the correct operation of the unit.

**⚠** The motorized valve can be omitted, inside the unit, if there is a motorized valve in the distribution manifold of the system and connected to the regulation card of the unit.



### 3.8.4 Connection with 2-way manual valve (I20686)

In case of choice for the 2-way manual valve:

- no electrical connection are necessary

• connect to the flow at the bottom

- A** unit body
- B** manual closing valve
- C** water inlet pipe fitting
- D** water outlet pipe fitting

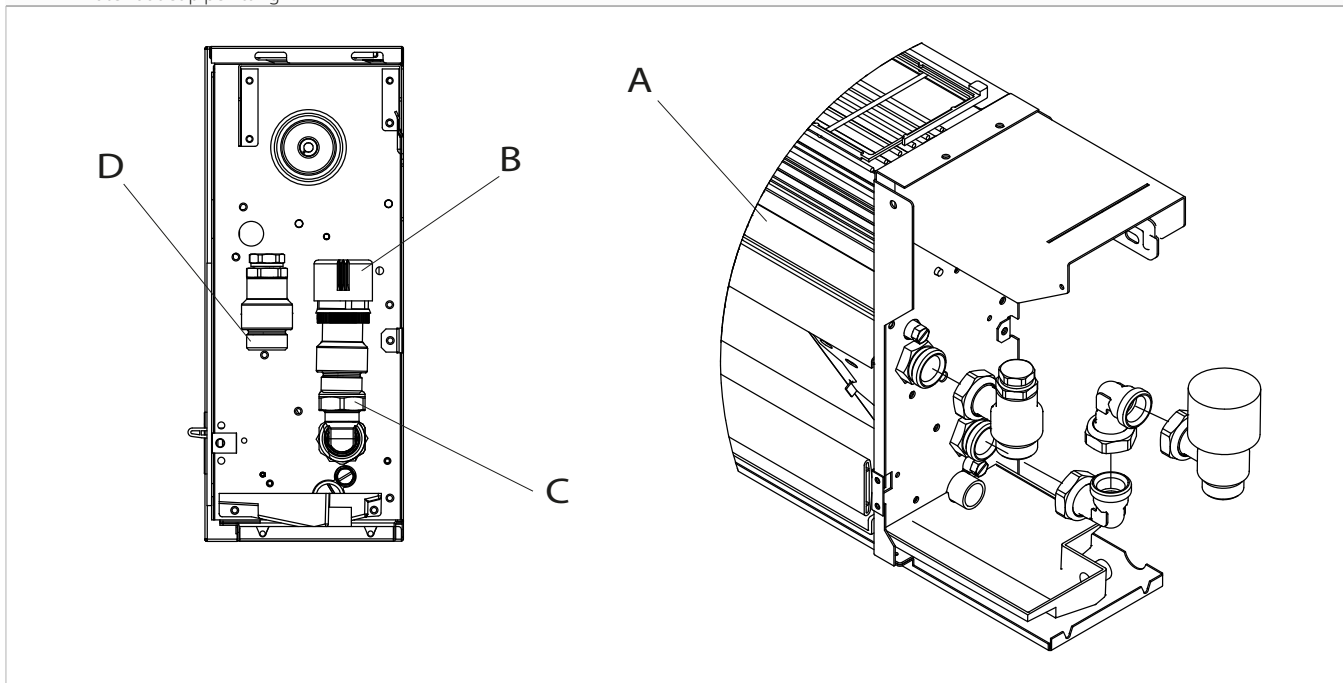

### 3.8.5 Connection with 2-way valve and thermoelectric actuator (V20687)

In case of choice for the 2-way valve and thermoelectric actuator:

electrical connection are required

- connect to the flow at the bottom

- A** unit body
- B** thermoelectric actuator
- C** fitting for water inlet pipe
- D** water outlet pipe fitting
- E** electrical cable entry hole

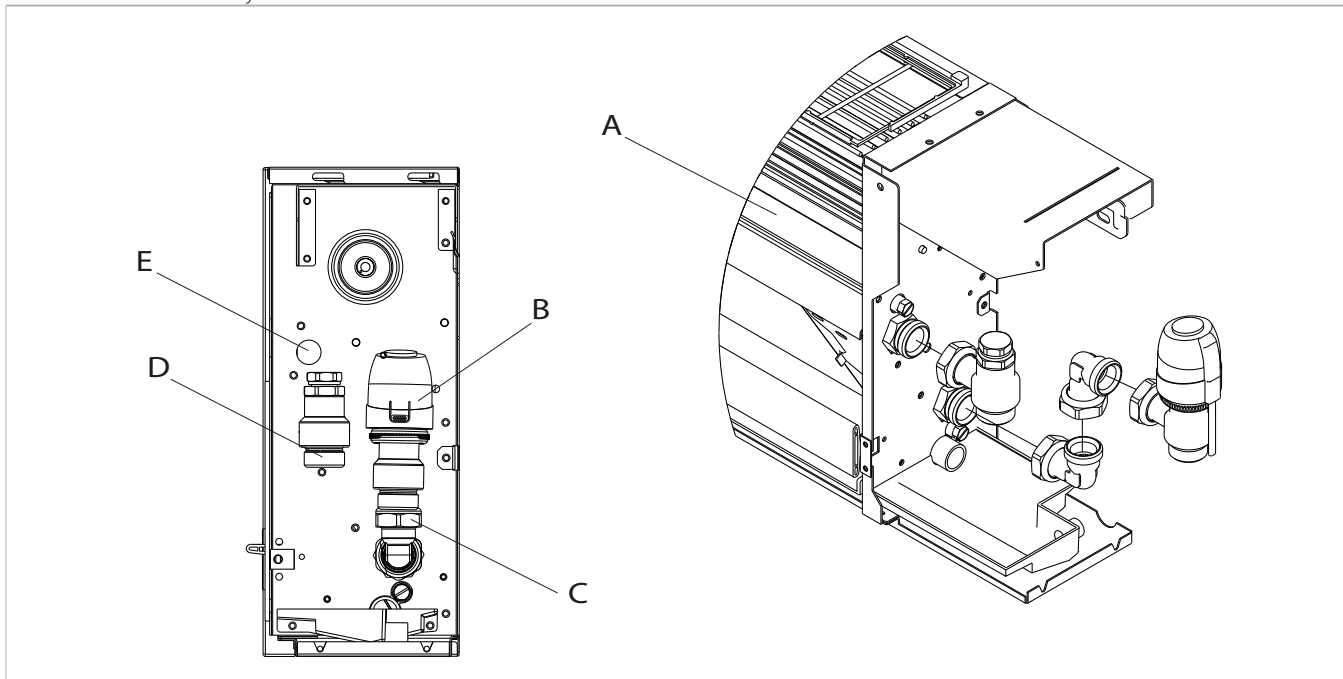

### 3.8.6 Connection with 3-way diverting valve unit with thermoelectric actuator (V30688)

In case of choice for the 3-way diverter valve unit with thermoelectric motor:

- electrical connection are required
- connect to the flow at the bottom

<b>A</b>	unit body
<b>B</b>	thermoelectric actuator
<b>C</b>	fitting for water inlet pipe
<b>D</b>	water outlet pipe fitting
<b>E</b>	electrical cable entry hole

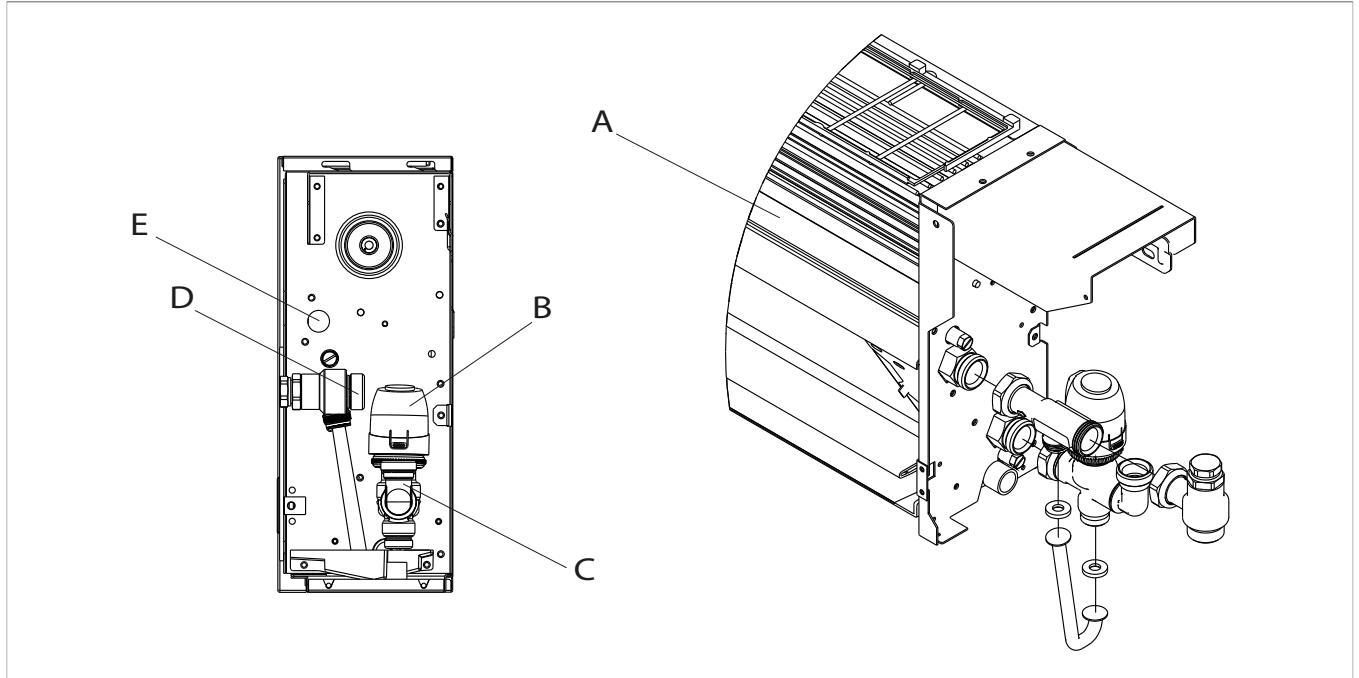

### 3.9 Condensation drain preparation

This appliance is complete with a tray for collecting the condensation produced during operation, which must be channelled to a suitable place for drainage. The size and positioning of the drainage tube are shown below.

1. drain connection, Ø 14 mm

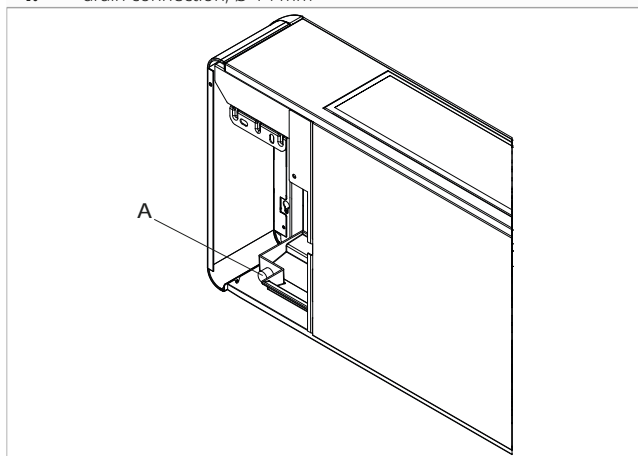

- ⚠ The hole for the condensation pipe must always slope towards the outside.
- ⚠ The exact position in which to place the pipe mouth is indicated on the template.
- ⚠ Check that the expelled water does not cause any damage or problems to people or objects. During winter, this water may create sheets of ice outside.
- ⚠ When connecting the condensation drain, be careful not to squeeze the rubber duct.
- ⚠ If you do not want to prepare an external drainage pipe in "heat only" mode, it is advisable to close the condensate drain with a plug.

#### 3.9.1 Preliminary warnings

- ⚠ If the line flows into a container (e.g. a tank), do not close the container hermetically and avoid immersing the draining pipe into the water.

### 3.9.2 Positioning

- A** drain connection
- B** the drainage tube

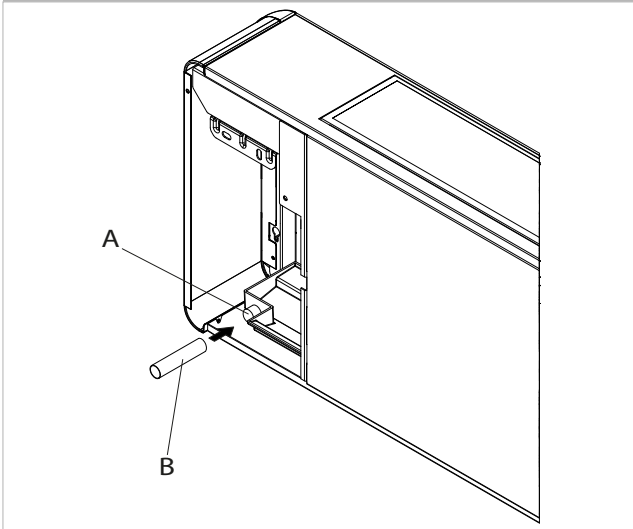

- connect a rubber drainage tube
- direct it to a suitable place for dropping

- A** Filomuro
- B** liquid drain pipe

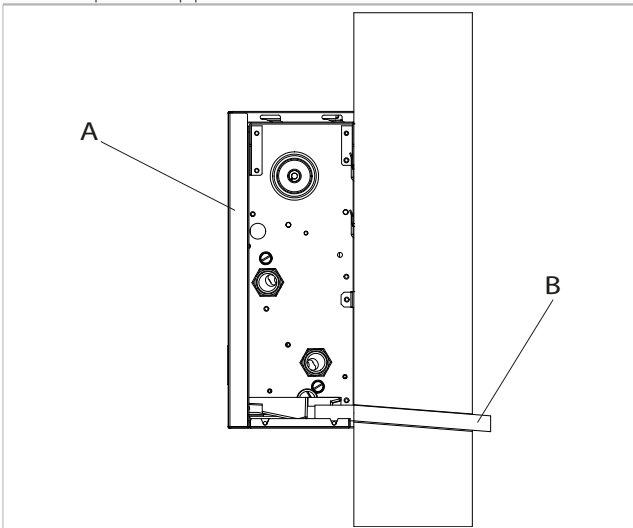

- provide a slope never less than 1%
- insulate fitting points

- ⚠ Pay attention to the tilt of the condensate drain pipe.
- ⚠ Use plastic drainage pipes.
- ⚠ Avoid pipes made of metallic material.
- ⚠ Make sure all joints are sealed to prevent leakage of water.
- ⚠ Condensate drainage pipes must be insulated for both indoor and outdoor sections of the house to avoid condensation on the surface and/or freezing problems.

**If using a jug for collecting the condensation:**

- ⚠ Avoid the hermetic closure of the container.
- ⚠ Prevent the end of the drainage tube from falling below the water level.

**If draining into the sewage system:**

- ⚠ Make a siphon to prevent bad smells returning up the pipe towards the room. The curve of the siphon must be lower than the condensation collection pan.
- ⚠ The syphon must feature a plug in its lower part or must otherwise allow for a quick disassembly for cleaning purposes.

- ⚠ Install a pump if the drain pipe is higher than lower level of pan.

**If using an open drain:**

- ⚠ Make the condensate liquid flow directly onto a gutter or into a "white water" drain
- ⚠ If the condensation is not collected, it will be deposited on the support surface. The water could freeze if the outdo-or temperatures are below zero, thus creating a hazard. In this case, appropriate barriers should be installed in order to prevent people from approaching the area.

### 3.9.3 Check

After the installation is completed:

- pour the water very slowly into the condensate drain pan
- check the right outflow

### 3.10 Filling the system

To fill the system:

- open the vent valves
- open all the system's shut-off devices
- slowly open the water tap

When water begins to leak out of the breather valves:

- close the breather valves
- complete system filling
- verify that you have reached the nominal pressure for the system
- close the water tap
- check the tightness of the gaskets

- ⚠ It is recommended to repeat this operation after the device has been running for a few hours.

- ⚠ Regularly check the system's pressure.

- A** Coil vent

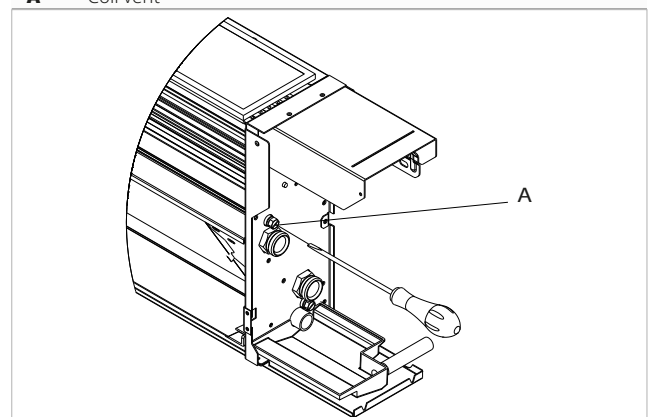

### 3.11 Electric connections

The device leaves the factory fully wired up and needs only the connection to the power supply, to any controls and accessories.

For the size of the power supply cable and safety devices, use the following table.

Models	m.u.	400	600	800
Power conductor (phase+neutral)	mm <sup>2</sup>	1,5	1,5	1,5
protective conductor section on ground	mm <sup>2</sup>	1,5	1,5	1,5
Circuit breaker	A	2	2	2

1. N.B. The values indicated refer to a maximum line length of 15 m.

**Make sure that:**

- the characteristics of the electric network are adapted to the absorption of the apparatus, considering also any other devices in parallel operation
- the power supply voltage and system frequency match to the values indicated on the device's plate data
- the cables must be appropriate for the type of installation in accordance with the applicable IEC standards

**It is required:**

- connect the device an efficient ground connection
- the use of a dedicated main switch fitted with time-delay fuse or with an automatic circuit breaker switch, installed near the device

⚠ The device is equipped with suppression filter as laid down by the applicable laws and standards. Use selective circuit breakers to compensate for the micro-dispersion on the ground of this device.

⊖ It is forbidden the use of gas and water pipes for grounding the appliance.

⚠ If you need to replace the power cable, contact only qualified staff and in compliance with the applicable national laws.

⚠ Disconnect the main circuit breaker before making any electrical connections and performing maintenance on the equipment.

#### 3.11.1 Access to the terminal block

⚠ Before doing any work, make sure that the supply power is disconnect.

To connect the power supply:

**A** terminal block for wiring

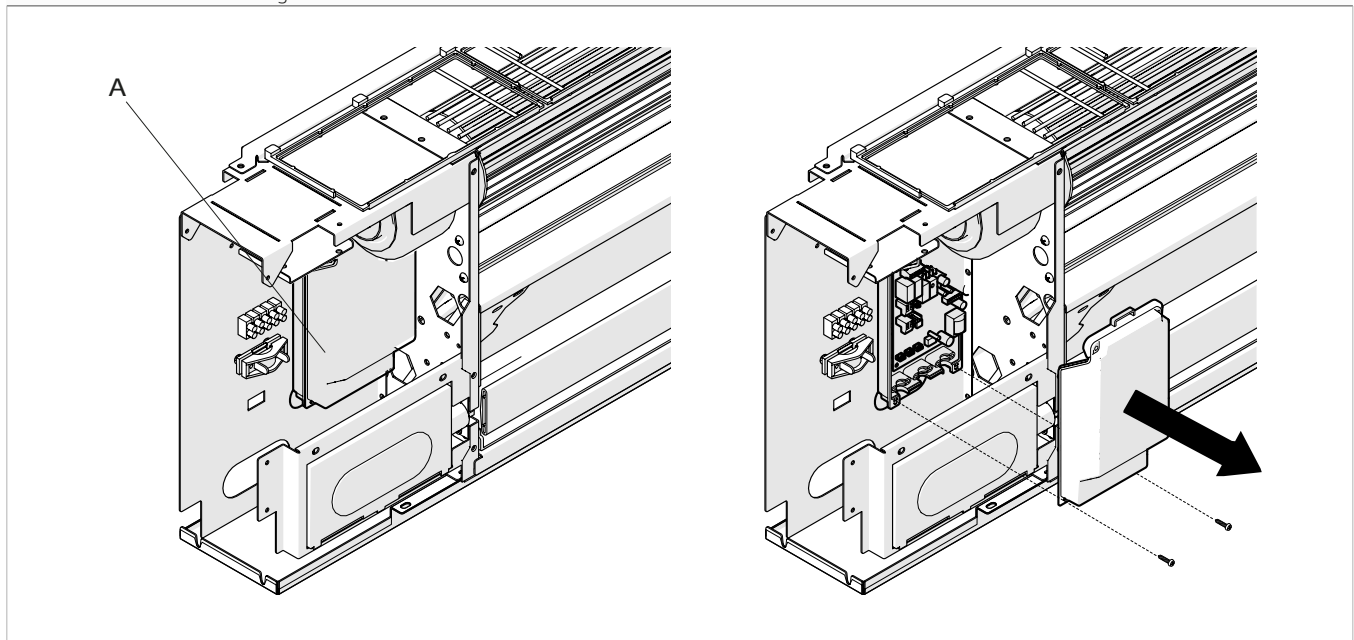

- bring the power cord to the terminal block
- making the connections
- refer to the information in the wiring diagram of the unit you are installing

check that the power supply is protected against overload and/or short-circuits.

You can use a cable embedded in the wall in the position traced with the installation template to make the electrical connection (recommended connection for devices installed in the upper part of the wall). In any case, you must

### 3.12 Diagrams and configurations electrical controls

#### 3.12.1 Touchpad and remote control (code suffix-0Q00)

##### Printed circuit board ECA689

The PCB is included in the supply.

<b>H2</b>	Water temperature probe
<b>M1</b>	Fan motor DC Inverter
<b>Y1</b>	Water solenoid valve ( 230 V/50 Hz 1 A power output)
<b>L-N</b>	230 V/50 Hz electrical power supply connection
<b>BO</b>	Heating request contact (for example boiler or heat pump). Activated in parallel with the output of the solenoid valve (Y1) with 1 minute delay when the fancoil is in heating mode and is on call (potential-free contact max. 1 A).
<b>CH</b>	Cooling request contact (for example chiller or reversible heat pump). Activated in parallel with the solenoid valve output (Y1) with 1 minute delay when the fancoil is in cooling mode and is on call (potential-free contact max. 1 A).
<b>CP</b>	Presence sensor input (if open, the fancoil goes into stand-by)
<b>AIR</b>	Air probe
<b>DIS</b>	Panel display wiring
<b>SM</b>	Step Motor connector

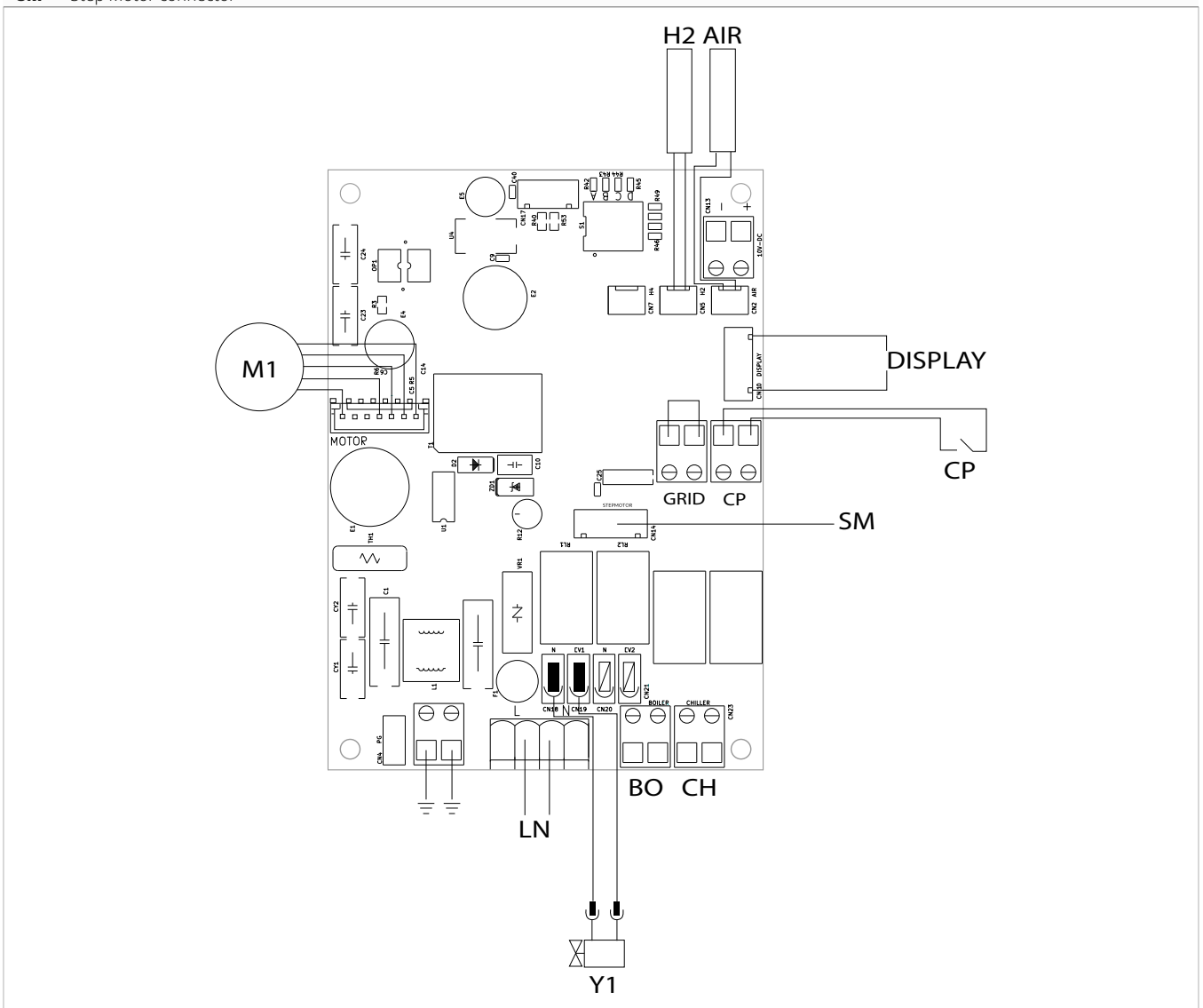

⚠ In the case of a single generator for heating and cooling (for example heat pump), simply connect the two contacts CH and BO in parallel and lead 2 wires to the generator.

**3.12.2 Remote control EEA649 - EEB649 / EFA649 - EFB649 (code suffix-0P00)**

**Printed circuit board ESE690**

The PCB is included in the supply.

<b>-AB+</b>	Serial connection for wall-mounted remote control (respect the AB polarization)
<b>H2</b>	Hot water temperature probe 10 kΩ
<b>M1</b>	Fan motor DC Inverter
<b>Y1</b>	Water solenoid valve ( 230 V/50 Hz 1 A power output)
<b>L-N</b>	230 V/50 Hz electrical power supply connection
<b>BO</b>	Heating request contact (for example boiler or heat pump). Activated in parallel with the output of the solenoid valve (Y1) with 1 minute delay when the fancoil is in heating mode and is on call (potential-free contact max. 1 A).
<b>CH</b>	Cooling request contact (for example chiller or reversible heat pump). Activated in parallel with the solenoid valve output (Y1) with 1 minute delay when the fancoil is in cooling mode and is on call (potential-free contact max. 1 A).
<b>CP</b>	Presence sensor input (if closed, the fancoil goes into stand-by)
<b>SM</b>	Step motor (diffuser)
<b>A</b>	led

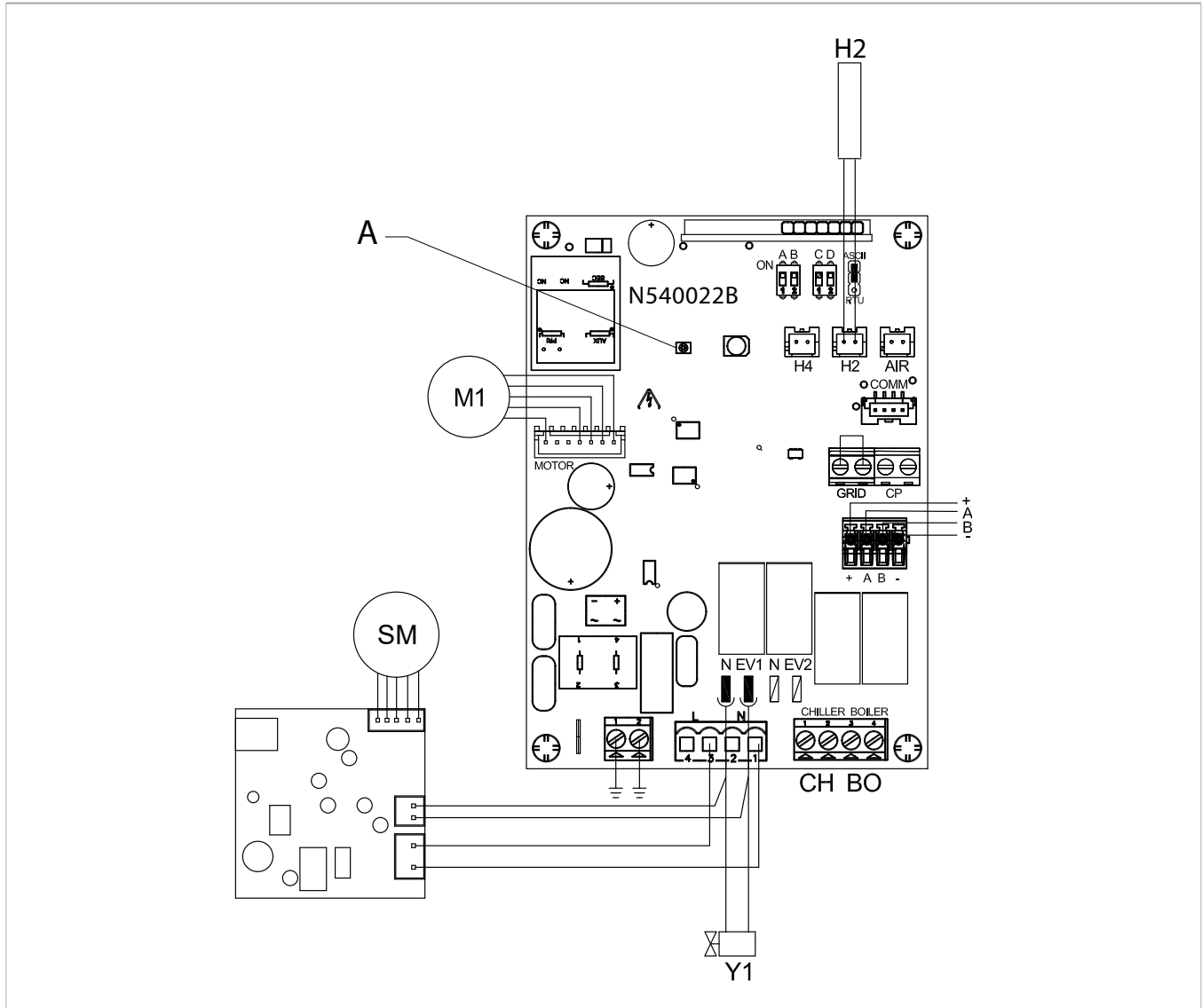

⚠ In the case of a single generator for heating and cooling (for example heat pump), simply connect the two contacts CH and BO in parallel and lead 2 wires to the generator.

## Control Panel EEA649 - EEB649 / EFA649 - EFB649

⚠ The control panel is to be ordered separately.

**A** Terminal blocks

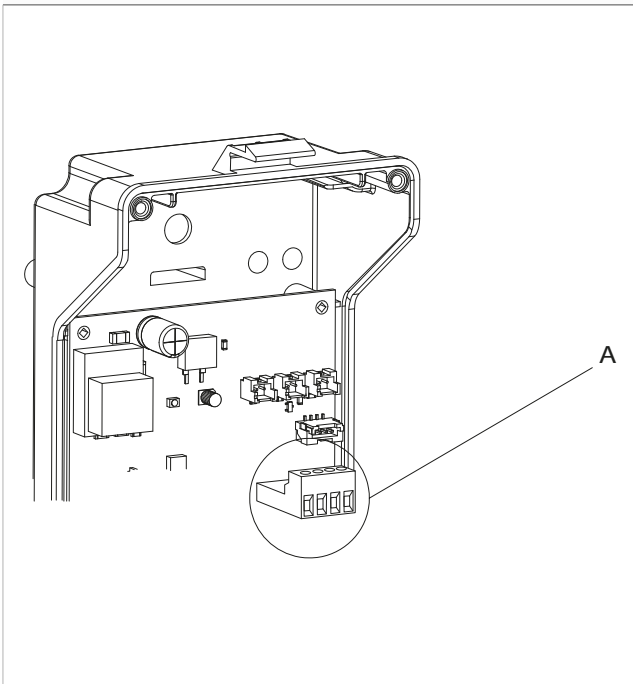

The terminal blocks for the connection of the wall-mounted controller accept:

- rigid or flexible wires with a 0.2 to 1 mm<sup>2</sup> cross-section
- rigid or flexible wires with 0,5 mm<sup>2</sup> cross-section if two wires are connected to the same terminal block
- rigid or flexible wires with 0,75 mm<sup>2</sup> cross-section If the wires have wire end ferrules with a plastic collar

To connect the cables:

- strip 8 mm of the wire
- if the wire is rigid, you can insert it easily whereas
- if it is flexible, it is advisable to use long nose pliers
- push the wire completely in
- check the right fixing by pulling it gently

**A** Terminal blocks

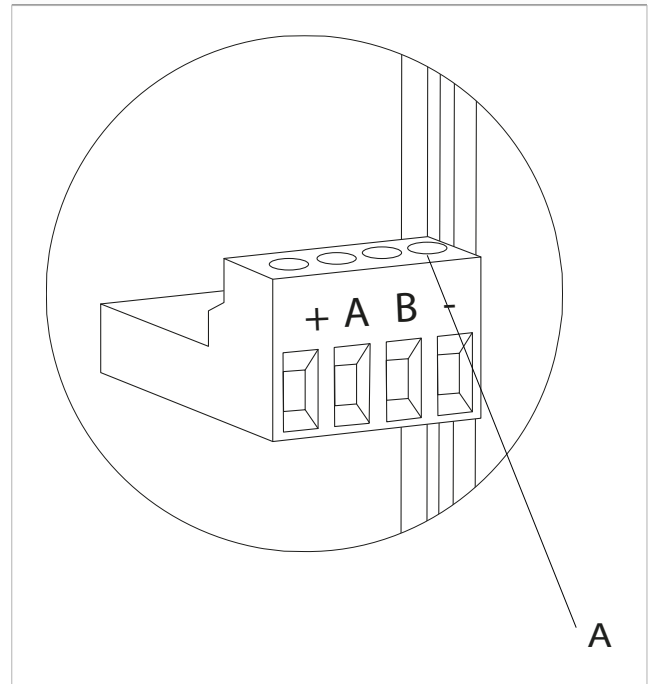

To disconnect the cables:

- unscrew the corresponding screw with a screwdriver
- remove the conductor

When the CP contact opens, connected to a clean contact not live, the unit is in stand-by. The display reads "CP".

### Error signals

The PCB is fitted with a LED, thanks to which it is possible to intuit the operating status.

#### LED signals

- LED off  
*Device switched off or without power supply*
- LED on  
*Normal operating of the device*
- LED 1 flash / pause  
*Water temperature probe H2 alarm not suitable, temporary stop of the ventilation until the temperature reaches an appropriate value \**
- LED 2 flashes / pause  
*Motor alarm (for example jamming due to foreign bodies or fault in the rotation sensor)*
- LED 3 flashes / pause  
*Water probe alarm disconnected or faulty*
- LED 6 flashes / pause  
*Communication error with the wall remote control. In case of a non-communication for more than 5 minutes the device is deactivated.*



2. \* In case of a operation without water probe H2, the fan stop thresholds will be ignored.

### 3.12.3 Setup menu EEA649 - EEB649 / EFA649 - EFB649



#### Setup menu

Through the control it is possible to access the settings menu.

##### To access the setup menu

- with the display off, hold down  for 10 seconds  
*The device turns on and the temperature appears*
- keep pressed until the indication  appears

##### To navigate in the menu

- use the icons  

##### To select a menu item and to confirm the changes made

- press the key  for about 2 seconds  
During the modification the symbol flashes to remind you that you are in the setup menu  
Confirming the change takes you to the next item

##### To exit the menu

- press the icon  for 10 seconds
- or wait 30 seconds the automatic shutdown



 After 30 seconds from the last action the control goes out and the settings is memorized.

#### Menu items

- Ad** Modbus address
- uu** Enable/Disable Wifi
- Ub** Adjust buzzer volume
- br** Adjust the brightness
- di** Digital input
- rZ** Enable/Disable radiant zone
- rb** Reset modbus
- Fr** Factory reset
- ot** Offset probe T
- oh** Reserved
- Sc** Scale
- rE** Reserved

#### Set the modbus address

##### To set the modbus address

- select 
  - increase or decrease the value with the icons  
- The setting range is from 01 (min) to 99 (max).*

#### Enable or disable Wifi



##### To enable or disable Wifi

- select 
  - select "YS" to enable wifi
  - select "rs" to reset the settings
  - select "no" to disable wifi
- By default wifi is enabled.*

 This function can only be used for controls with integrated WiFi (EFA649 - EFB649).

#### Adjusting buzzer volume



##### To change the volume

- select 
  - increase or decrease the value with the icons  
- The volume setting range is from 00 (min) to 03 (max).*



 The volume changes after confirm the modification.

#### Adjust the brightness of the display

##### To adjust the brightness of the display

- select 
  - increase or decrease the value with the icons  
- The brightness setting range is from 00 to 01.*

 The display brightness changes after confirm the modification.



 You can also reduce the brightness of the display through the keys of the control. With the display off, hold down  for about 20 seconds, the message "01" will appear. Press  to decrease the brightness to "00". Wait 30 seconds for the correct setting to be checked.

#### To select digital input

##### To change the digital input

- select 
  - select CP for potential-free contact (default)
  - select CO to cooling open
  - select CC to cooling close
- By default digital input is set to CP.*

 For return to the default settings, set the digital input to "CP".

 By selecting one of the other inputs (CO,CC) the seasonality is locked. It is not possible to modify it through the key  of the control.

#### Enable the radiant zone

##### To enable the radiant zone

- select 
  - select "no" to disable the radiant zone
  - select "YS" to enable the radiant zone
- By default the radiant zone are disabled.*

 This function can only be used for wall controls (EEA649 - EEB649 / EFA649 - EFB649) combined with the EF1027 board.



## Reset modbus

- select **rb**
- select "no" to keep the current settings
- select "YS" to reset the settings

## Factory reset

### To reset the control to factory settings

- select **Fr**
- select "YS" to reset the settings
- select "no" to keep the current settings

## Probe T regulation offset (room temperature probe)

### To adjust the probe T

- select **ot**
  - increase or decrease the value with the icons **—**  
**+**
- The setting range is from -9 to 12.*

- ⚠ Use this adjustment carefully.
- ⚠ This adjustment must be carried out only after having found actual deviations from the room temperature using a reliable tool.
- ⚠ Adjust the value within a range of -9 °C to +12 °C, in steps of 0,1 °C.
- ⚠ After 30 seconds from the last action the control goes out and the settings is memorized.

## Scale

### To change the temperature unit of measure

- select **Sc**
  - select °C o °F
- By default the temperature unit of measure is °C.*

**3.12.4 Remote control with fixed speed (code suffix-0T00)**

**Printed circuit board B4V698**

The PCB is included in the supply.

<b>N-L</b>	230 V/50 Hz electrical power supply
<b>EV</b>	Solenoid valve permission input
<b>V1</b>	Maximum fan speed 1,400 rpm
<b>V2</b>	Medium fan speed 1,100 rpm
<b>V3</b>	Minimum fan speed 680 rpm
<b>V4</b>	Super-silent speed 400 rpm
<b>E</b>	Heating, cooling selection input
<b>Y1</b>	Water solenoid valve ( 230 V/50 Hz 1 A power output)
<b>M1</b>	Fan motor DC Inverter
<b>SM</b>	Step motor (diffuser)
<b>TA</b>	3 speed room thermostat (to buy, install and connect by the installer)
<b>CV</b>	Thermostat consent
<b>SV</b>	Speed selector
<b>H2*</b>	Water temperature probe 10 kΩ
<b>*</b>	Located in the battery on the unit.

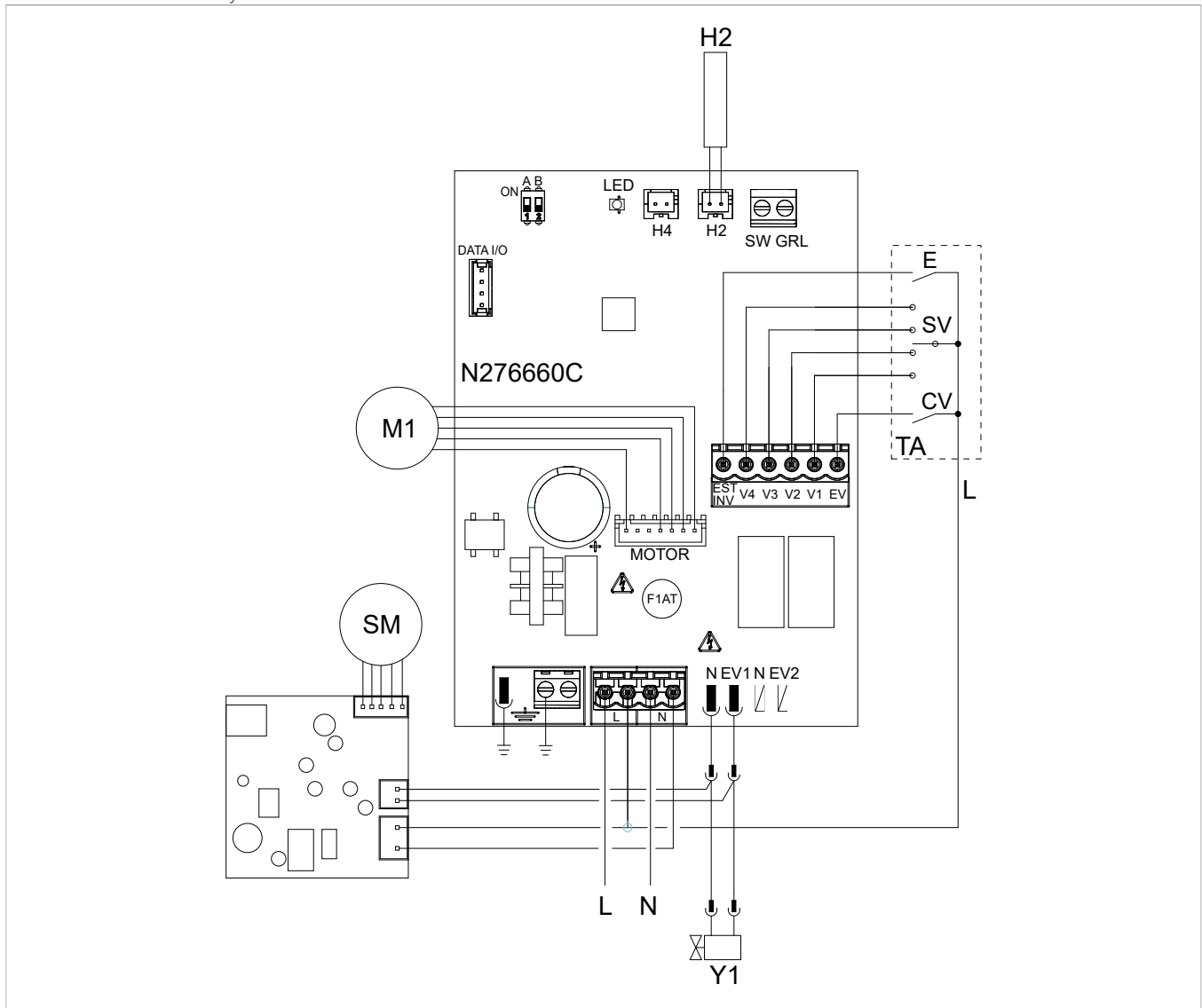

## Connection with 3 speed thermostats

The CV input is the ON/OFF of the board:

- in case of opened input the PCB is placed in stand-by
- in case of closed input the PCB is in operation

To activate the electrovalve Y1 the CV input must be bridged to clamp L of the 230 V electric power supply.

To activate the fan, connect the V1, V2, V3, V4 inputs to clamp L of the 230 V electric power supply. The inputs control the ventilation speed:

- V1 - maximum fan speed (equal to 1400 rpm)
- V2 - medium fan speed (equal to 1100 rpm)
- V3 - minimum fan speed (equal to 680 rpm)
- V4 - supersilent speed (equal to 400 rpm)

Connect the 3 speeds of the thermostat to three of the four available inputs based on the characteristics and use of the location. Examples:

- residential application where maximum silence is required, connect V2, V3 e V4
- commercial application where the heating capacity is the main aspect, connect V1, V2 and V3

In the event of simultaneous closure of several inputs, the motor will run at a number of revolutions equal to that set by the connection with the highest speed.

You can connect several boards in parallel to a single thermostat, even using different speed.

## Water probe

In case of connection with electromechanical thermostats or commercial commands provided with water probe:

- the on-board H2 probe will not be connected
- the device will be controlled from the remote command

If this is not the case, connect the 10 kΩ probe located inside the battery to the H2 connector on the PCB.

The printed circuit board works in:

- minimum water temperature for heating function (<30 °C)
- maximum water temperature for cooling function (>20 °C)

In case of temperature not suitable for active operation:

- the ventilation stops
- error is indicated by the flashing of the LED on the PCB

The Heating/Cooling discriminant is implemented through the EST/IN input of the board:

- with input open the board goes into Heating mode
- with input closed the board goes in Cooling mode

It is possible to use the device without the water probe activated. In this case the error is signaled on led.

To confirm operation without the probe:

- disconnect and connect the board power

This condition is stored by the board for all subsequent startups. Connect the probe to restore the normal functions.

## Error signals

### LED signals

- LED off  
*The CV contact is open, stand-by condition*
- LED on  
*The CV contact is closed, normal operation*
- LED 1 flash / pause  
*Water temperature probe H2 alarm not suitable, temporary stop of the ventilation until the temperature reaches an appropriate value*

- LED 2 flashes / pause  
*Motor alarm (for example jamming due to foreign bodies or fault in the rotation sensor)*
- LED 3 flashes / pause  
*Water probe alarm disconnected or faulty*

**3.12.5 Remote control with modulating speed (code suffix-0V00)**

**Printed circuit board B10699**

The PCB is included in the supply.

<b>L-N</b>	230 V/50 Hz electrical power supply
<b>10V</b>	Device pilot input 0÷10 V. Input impedance 25 kΩ
<b>Y1</b>	Water solenoid valve ( 230 V/50 Hz 1 A power output)
<b>M1</b>	Fan motor DC Inverter

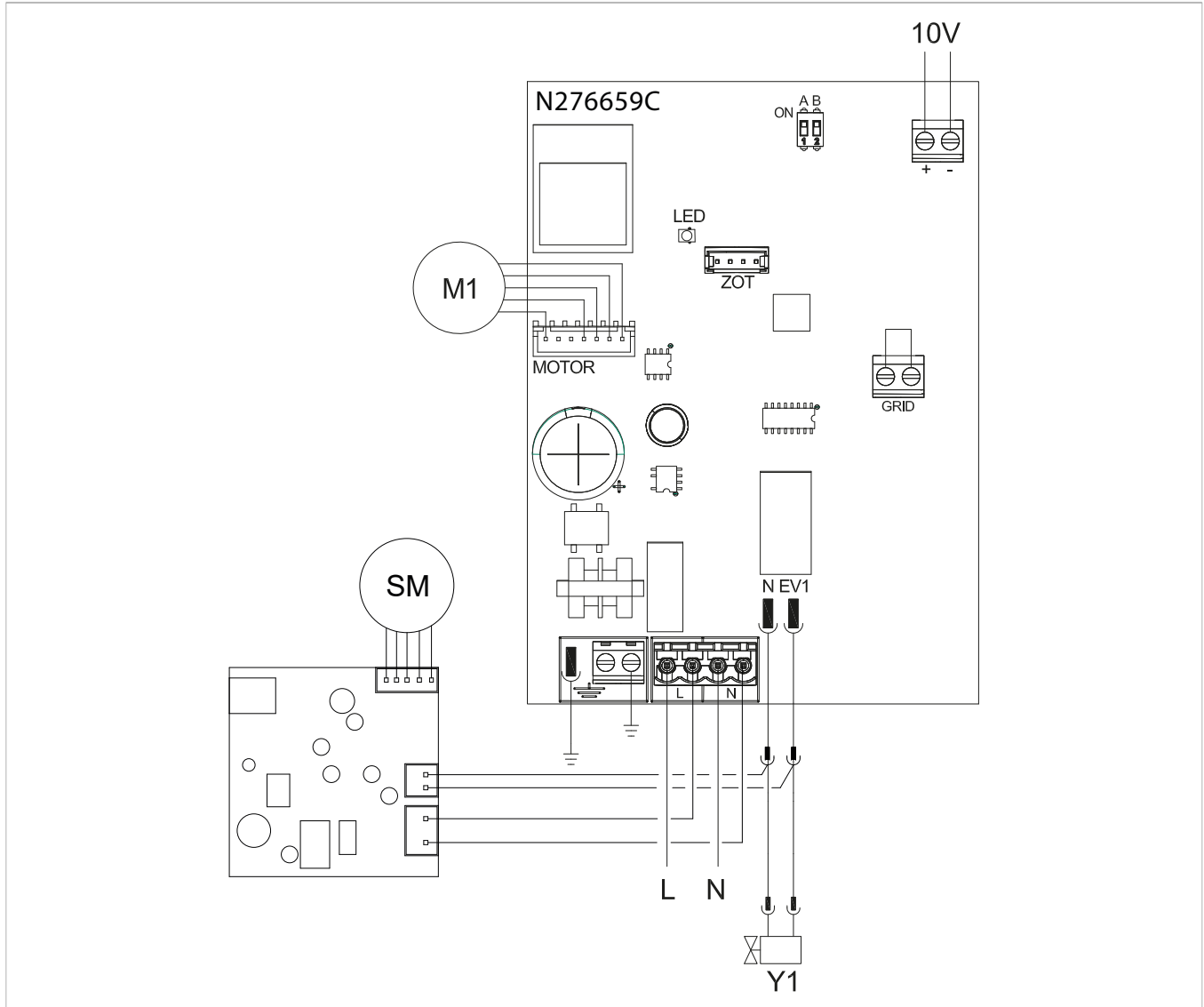

## Connection with 0-10 V thermostats

The 10 V input activates solenoid valve Y1 and adjusts the number of rotations of the fan. The speed range provides a linear adjustment from the minimum value (400 rpm) to the maximum value (1400 rpm) for voltage values  $\geq 1,1$  V  $\div$  10 V DC.

The solenoid valve Y1:

- is enabled by voltage values  $> 1$  V DC
- turns off with values  $< 0,9$  V DC

## Error signals

### LED signals

- LED off  
*The input signal is below 0,9 V*
- LED on  
*Normal operation, the input signal is greater than 1 V*
- LED 2 flashes / pause  
*Motor alarm (for example jamming due to foreign bodies or fault in the rotation sensor)*

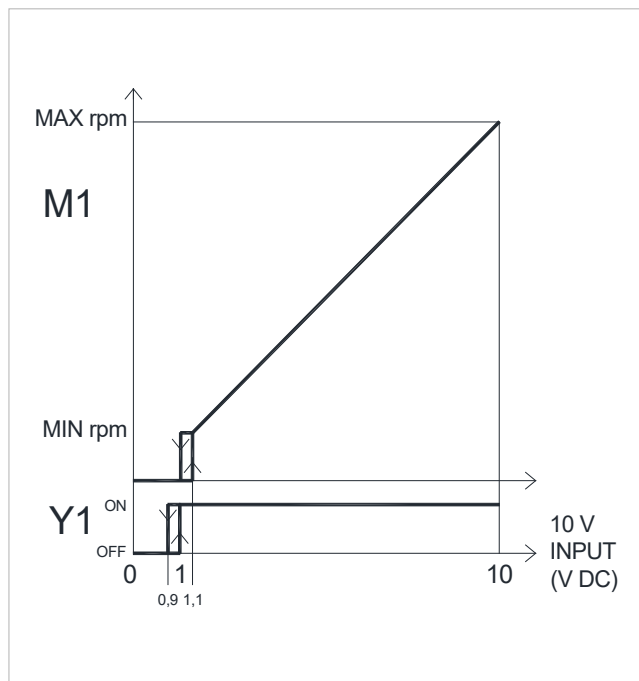

## UNIT WITH TOUCHPAD AND REMOTE CONTROL

### 4.1 Interface

#### 4.1.1 Description

⚠ The solution with touch pad and remote control is recommended for the prevalent use in cooling.

The display on the appliance allows you to:

- show the operating status
- show any alarms
- select the various functions by pressing on the symbols

The remote control allows you to:

- select the various functions by pressing on the symbols

⚠ The remote control supplied with the device is designed to provide maximum sturdiness and exceptional functionality, but should nonetheless be handled with caution.

⚠ Warnings:

- Do not expose the remote control to rain or contact with liquids.
- Do not expose the remote control to direct sunlight.
- Handle with care avoiding strong impacts or falling on hard surfaces.
- Do not placing obstacles between the remote control and the device while you are using the remote.

⚠ Important:

- If other devices are being used within the premises that are operated by remote control (TVs, radios, stereos, etc.), you might experience some interference.
- Electronic and fluorescent lamps can interfere with communications between the remote control and the device.
- Electronic and fluorescent lamps can interfere with communications between the remote control and the device.

#### 4.1.2 Display

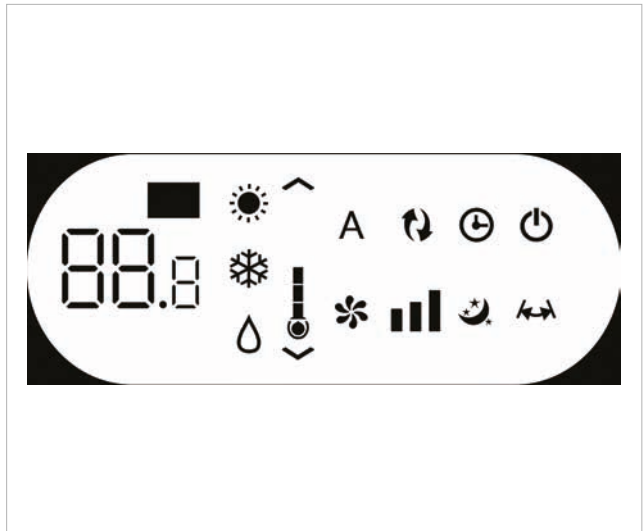

Keys and functions related.

	Setpoint
	Up key
	Down key
	On/off key
	Not used
	Key to enable cooling only mode
	Not used
	Key to enable ventilation only mode
	Key to enable heating only mode
	Night comfort key
	Airflow direction control key
	Fan speed control key
	Key to set the Timer function
	Digital thermometer 1÷7 bars - red in winter, blue in summer
	Not used

### 4.1.3 Remote control

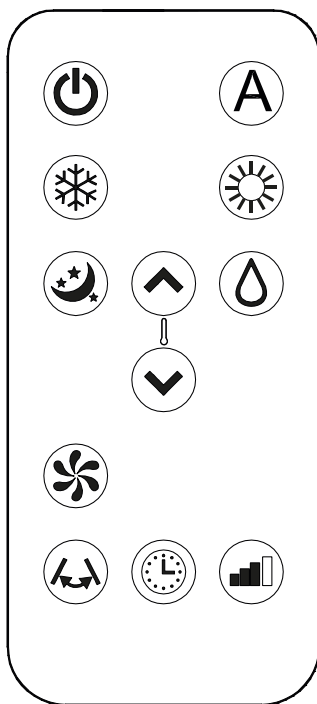

Keys and functions related.

	Up key
	Down key
	On/off key
	Not used
	Key to enable cooling only mode
	Not used
	Key to enable ventilation only mode
	Key to enable heating only mode
	Night comfort key
	Airflow direction control key
	Fan speed control key
	Key to set the Timer function

### Inserting the battery

- open the slot on the bottom of the remote control
- insert the battery according to the +/- polarity
- Close the cover after inserting the battery.

**⚠** Use only a dry 3 V lithium battery CR2025 (included) with the remote control.

**⚠** Used batteries must be disposed of appropriately (WEEE) through special waste collection centres provided by the local authorities.

### 4.1.4 General start-up

To control the device with the remote control or touch-screen display:

- enable the main switch on the power line (the technician who installed the device can help you locate the switch), or introduce a power plug on the device, plugging it into the system's socket

After you perform these steps, you can operate the system either by pressing the symbols on the touch-screen display or using the remote control.

Correct use of the remote control:

- point the front of the remote towards the unit's display, the buzzer will emit a beep and a message will appear on the display to confirm that the command has been enabled
- the maximum range to send commands is about 8 metres

#### To activate the device

- press the key  
*The display lights up*  
*The preset set-point appears on the 3 digits of the display.*

**⚠** The control panel has its own memory, therefore no settings will be lost in case of shut-down or power outage (except ventilation). The button in question is used to switch the appliance on and off for short periods.



**⚠** If you plan to keep the device out of service for a prolonged time, remember to deactivate it by disconnecting the power or removing the power plug.

## 4.2 Main functions

⚠ The keys of the remote control and touch-screen display perform the same function.

### 4.2.1 Set room temperature

#### To set-up the temperature



- use the   keys to increase or decrease the desired value  
*The displayed value change*

⚠ The room temperature set-point can range between 16 and 31 °C.

⚠ Do not set a temperature that is too low or too high is harmful to health and is an unnecessary waste of energy.

### 4.2.2 Cooling only mode



#### To select the Cooling operation

- press the  key for about 2 seconds  
*The symbol  on indicate the Cooling function enable*

When this operating mode is enabled, the device dehumidifies and cools the room. With setpoint lower than the room temperature, the fancoil starts and starts supplying cold air, keeping ventilation active even if the setpoint is reached.

### 4.2.3 Ventilation only mode

#### To select the Ventilation operation







- press the  key for about 2 seconds  
*The symbol  on indicate the Ventilation function enable*

When you enable this function, the device enable the fan and does not adjust the temperature or the humidity of the air in the room.

You can choose the fan speed

### 4.2.4 Set the speed

#### To select the fan speed control

- press the key   
*The  symbol varies according to the ventilation speed with the following sequence:*
-  Minimum
-  Medium
-  Maximum
-  Automatic (you will notice the 3 speed bars slide on the display)



⚠ The higher the set speed, the higher the device's performance (but also the louder the noise).

⚠ If you set the speed to Automatic the micro-processor will adjust the speed automatically (the higher the difference between the room temperature and the set temperature, the higher the speed). The speed is reduced automatically as the room temperature gradually reaches the set temperature.

⚠ In dehumidification only mode and night comfort mode, you cannot adjust the speed, as the unit can work only at low speed.

### 4.2.5 Heating only mode



#### To select the Heating operation

- press the  key for about 2 seconds  
*The symbol  on indicates the Heating function enable*

When this operating mode is enabled, the device heats the room. With setpoint higher than the room temperature, the fan coil starts and starts supplying hot air.

### 4.2.6 Night function

#### To select the Night comfort function

- press the  key for about 2 seconds  
*The symbol  on indicate the Night comfort function enable*

⚠ In this mode the fan is set to minimum speed.

⚠ The set temperature changes automatically:

- in heating function decreases by 1 °C after one hour and by another degree after 2 hours
- in cooling function decreases by 1 °C after one hour and by another degree after 2 hours
- In both cases after the second hour the setting of the temperature set is not further altered and after 6 hours the appliance is put on stand-by



⚠ This function is not available in the dehumidification only and ventilation only.

⚠ This function can be excluded at any time by pressing the button further.



⚠ If you simultaneously set the Timer function, the device switches off after the preset time.

### 4.2.7 Set the direction of the air flow

#### To control the air flow direction

- press the  key for about 2 seconds  
*The symbol  lit on indicates the constant oscillation of the air flow deflector*

#### To lock the airflow direction again



- press again the  key  
*The symbols  goes off and the air flow deflector locks in position*

⚠ Never force the flow deflector manually to move it.

⚠ In cooling and dehumidification mode, the flow deflector's position is reset every 30 minutes in order to prevent the formation of dew.



### 4.2.8 Setting the Timer function

#### For setting the Timer function





- press the  key for 5 seconds  
*The symbol  on indicates the Timer function enable*

This function allows the user to freely program when to switch the appliance on or off







#### To program the activation of the appliance

- with the display off, press the  key for 5 seconds  
*The symbol  on indicates the Timer function enable*





- select with   the number of hours (from 1 to 24 h) after which the appliance will be switched on automatically
- press again the  key to confirm the setting *the display lights up in full showing the settings (setpoint, active functions, etc.) that will be activated with the automatic switching on of the appliance*
- press again the  key to confirm the setting

#### To program the stand-by of the appliance

- press the  key for 5 seconds  
*The symbol  on indicates the Timer function enable*
- with the arrows   select the number of hours (from 1 to 24 h) after which the appliance will be automatically turned off
- press again the  key to confirm the setting *the display lights up in full showing the active settings (setpoint, functions, etc.)*
- press again the  key to confirm the setting



### 4.2.9 Set the key lock

#### To set-up the key locking

- press the  key for 10 seconds  
*The display lights up in full showing the active settings and the  key flashes with a frequency of 1 second*

*Any action is prevented by the user*



#### To turn off the key-lock

- press the  key again for 10 seconds  
*The display lights up in full showing the active settings and the  key remains fixed*

### 4.2.10 Deactivate-put in stand-by the control



#### To deactivate or put in stand-by the control



- press the  key for about 2 seconds  
*The control goes out*

-  The control panel has its own memory, therefore no settings will be lost in case of shut-down or power outage (except ventilation).
-  In stand-by mode, the control guarantees antifreeze protection.
-  If you plan to keep the device out of service for a prolonged time, remember to deactivate it by disconnecting the power or removing the power plug.

## 4.3 Warnings

### 4.3.1 Visualization of alarms on display

-  In the event of a malfunction, the display shows an alarm code.
-  In the event of an alarm, the device still maintains active functions.

E1	Room temperature probe (RT) failure It is possible to normally activate the Cooling, Dehumidification and Heating modes.
E2	Internal battery probe IPT failure It is possible to normally activate the Cooling, Dehumidification and Heating modes.
E5	Indoor fan motor failure You cannot activate any operating mode
E7	Lack of communication with the display You cannot activate any operating mode
CP	Presence contact CP open The unit is enabled only if the contact is closed, check the connection of the terminals
	lampeggiante      Incorrect water temperature In heating mode, the water temperature is below 30 °C
	lampeggiante      Incorrect water temperature In cooling mode, the water temperature is above 20 °C

### 4.3.2 Operating the unit if the remote control is not available

If you lose the remote control, the batteries run out or the remote stops working, you can operate the device with

the keys on the touch-screen display on-board the machine.

### 4.3.3 Troubleshooting

For the user it is important to distinguish any malfunction or performance levels that differ from the system's standard operating values (see technical specifications). The most common problems can be easily solved by the user by performing certain simple tasks (see the Troubleshooting paragraph), while some system alarms require that you contact the Technical Customer Service.

-  Please keep in mind that any attempt by unauthorised staff to repair the device automatically voids any form of warranty.

# WALL MOUNTED REMOTE CONTROL EEA649 - EEB649 / EFA649 - EFB649

## 5.1 Installation

### 5.1.1 Description

The wall-mounted control panel is a thermostat with possibility of control on several device equipped with electronic control for remotization.

- ⚠ The control can control up to a maximum of 30 units.
- ⚠ The temperature probe can be remoted in one of the connected device.

### 5.1.2 Mounting

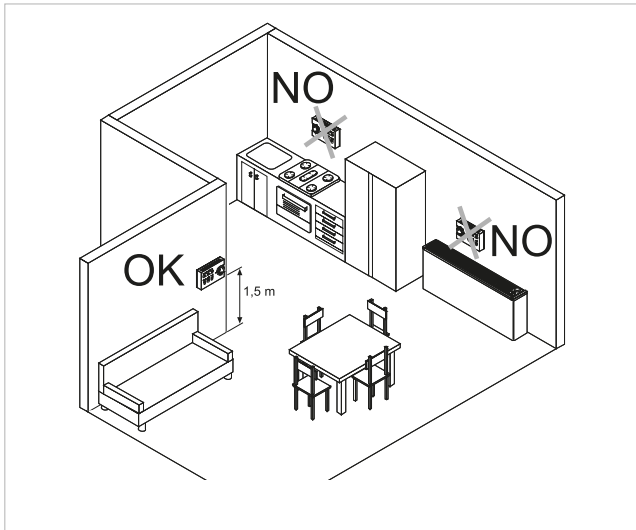

The wall-mounted remote control must be installed:

- on internal walls
- at a height of about 1,5 m from the floor
- away from doors or windows
- away from heat sources (heaters, convectors, stoves, direct sunlight)

- ⚠ The wall-mounted remote control is provided inside the package already assembled.

**A** Notches

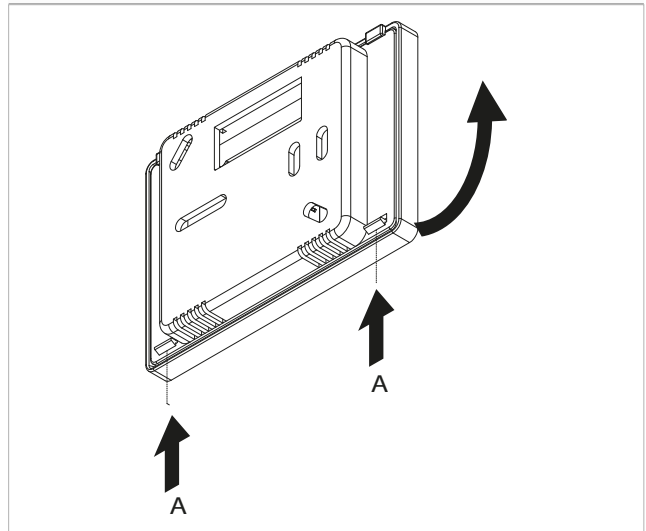

Before wall installation:

- Unhook the protruding notches on the back side of the control.
- separate the base from the control
- use the base of the control to trace the fixing point on the wall

- A** Base of the control
- B** Holes for the wall mounting
- C** Screws
- D** Hole for the passage of the electrical connections

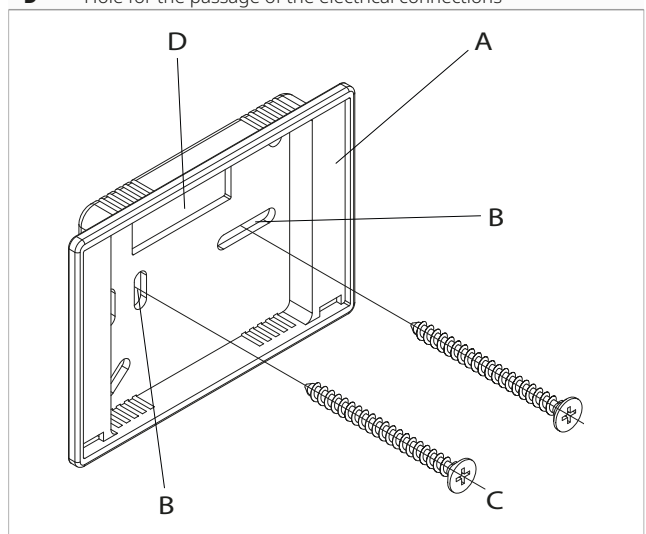

For the remote control wall mounting:

- drill holes in the wall
- pull the electric wires through the hole provided
- fix the base of the control to the wall using suitable screw and plugs

- perform the electrical connection
- close the control

**⚠** Pay attention not to crush the conductors when you close the control.

## 5.2 Electric connections

### 5.2.1 Connection diagram

1. Terminal block for device connection
2. The terminal block for CP presence contact connection
3. PCB

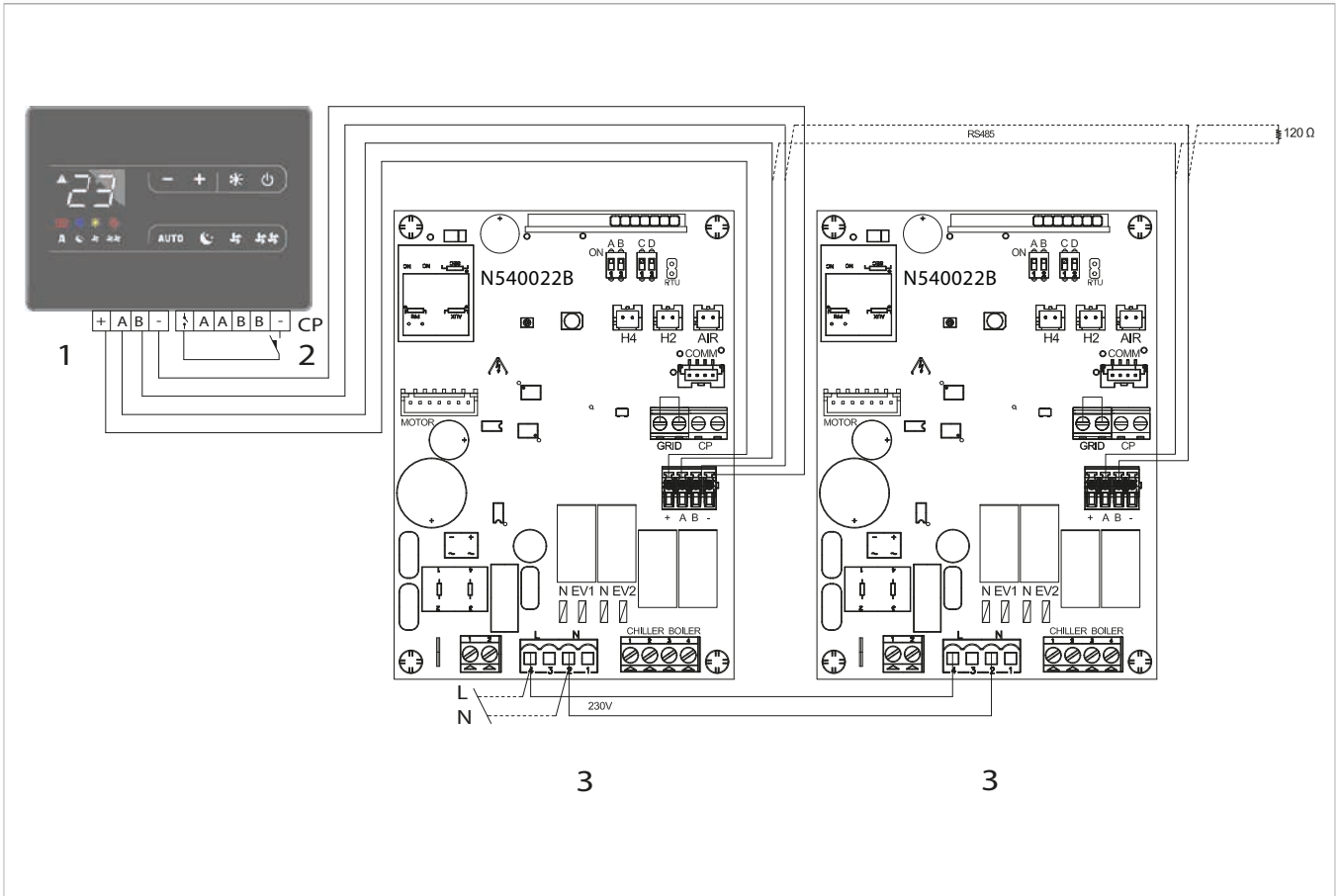

### 5.2.2 Terminal block position

**A** Terminal block

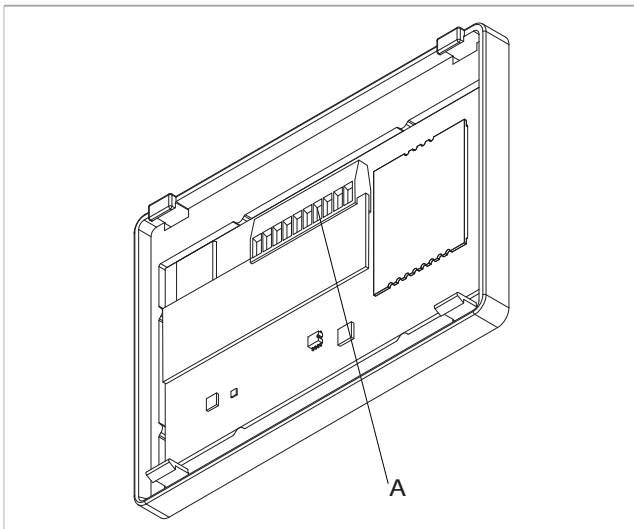

The spring terminals allow the connection of rigid or flexible cables with sections from 0.2 to 1 mm<sup>2</sup>. For cables provided with lugs with plastic collar the maximum section is reduced to 0,75 mm<sup>2</sup>.

### 5.2.3 Connection to the PCB

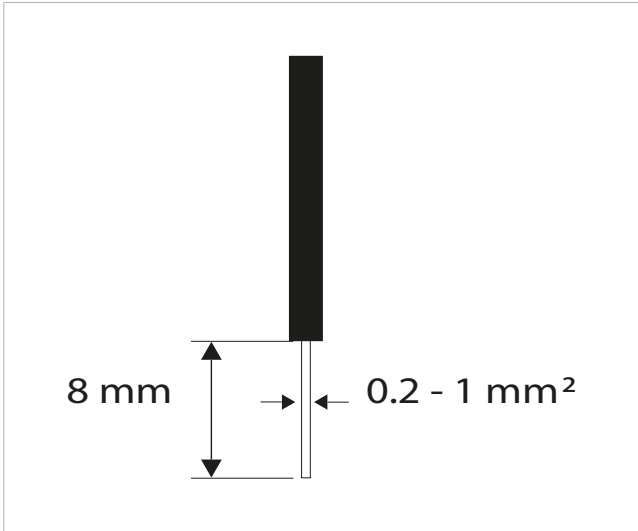

- For the connection:
- remove a portion of the insulation from the end of the cable
  - follow the indication on the connection diagram
  - insert the cable into the spring terminal
  - insert the cable completely
  - make sure they are properly fixed by pulling them slightly

### 5.2.4 CP presence contact input connection

Trough this contact it is possible connect an external device that inhibits the operation of the device, for example:

- opening window contact
- remote on/off
- infrared presence sensor
- enabling badge
- remote change of season

#### Function

When the contact connected to the CP input is closed, all the users connected will be switched off.





At the touch of a button on the display  the symbol flashes.

-  It is forbidden connect in parallel the CP input to one of another electronic board. Use separate contacts.

### 5.2.5 RS485 Serial Connection

The wall-mounted remote control can be connected through a RS485 serial line to one or more device, for a maximum of 30. The devices must be equipped with an electronica card suitable for remotization.



For the connection:

- follow the indication on the connection diagram
  - connect respecting the indication "A" and "B"
-  Use a bipolar shielded cable suitable for the RS485 serial connection with a minimum section of 0,35 mm².
  -  Keeping the bipolar cable separate from power supply cables.
  -  Chase out the wall in order to minimize the length of the leads.
  -  Complete the line with the 120 Ω resistance.
  -  It is forbidden make "star" connections.

## 5.3 Interface

### 5.3.1 Description

The wall-mounted control panel EEA649-EEB649 / EFA649-EFB649 is a thermostat with possibility of control on several device equipped with electronic control for remotization. It is fitted with:

- temperature probe
  - internal memory with data saving even in case of shut-down or power outage
-  The control can control up to a maximum of 30 units.
  -  The room temperature probe ensures an antifreeze safety even when the control is in stand-by
  -  After 20 seconds after the last action the panel brightness is reduced, only the room temperature is seen on the display. The maximum brightness is restored to the pressure of any key.

### 5.3.2 Display

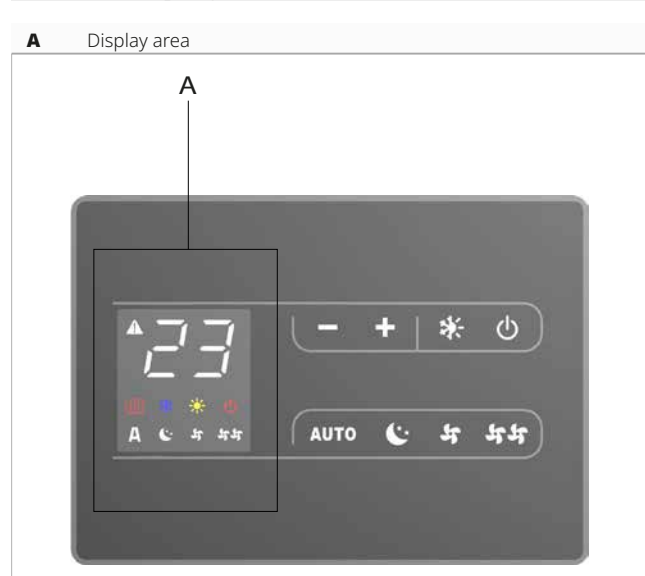



Statuses and active alarms on display.

 Supervision on  
Flashing with CP closed contact  
Switched on for alarm indication

 Resistance enabled indication

 Cooling function on

 Heating function on

 Remote control indication off

**A** Automatic function

 Night function

 Silent function

 Maximum ventilation speed

### 5.3.3 Keys functions

**A** Keys area

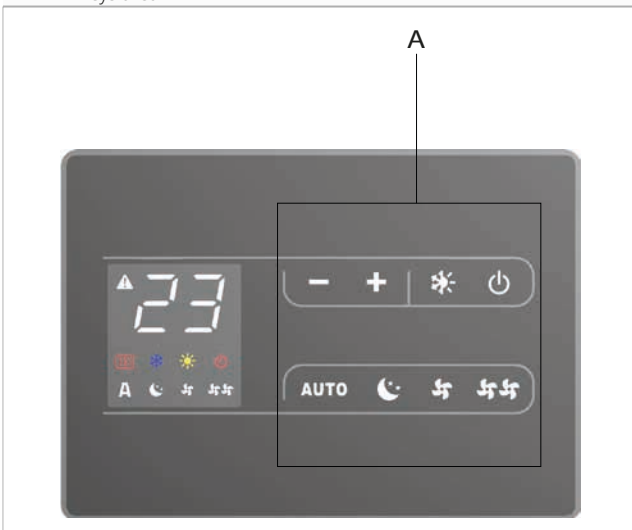

Keys and functions related.

 Down key

 Up key

 Allows switching between heating and cooling functions

 Allows activating or putting the device in stand-by

**AUTO** The ventilation speed will be adjusted automatically between a minimum and a maximum value

 The ventilation speed will be reduced and the set temperature will be changed automatically

 The ventilation speed will be limited to a maximum contained value

 Allows setting the maximum ventilation speed



### 5.3.4 General start-up

Before the activation:

 Make sure that the remote control is connected to the mains.

 In case of a master switch on the power supply line, switch on the system by inserting the switch.



#### To activate the device

- press the  key  
the symbol  lights up

## 5.4 Main functions

### 5.4.1 Operating mode set-up

#### to switch the operating mode

- press the  key for about 2 seconds  
The symbol  on indicates the Heating function enable  
The symbol  on indicate the Cooling function enable

 In heating function the symbols is a light with setpoint higher than the room temperature.

 In cooling function the symbols is a light with setpoint lower than the room temperature.

 When the setpoint is incorrect both symbols are switched off.

### 5.4.2 Put in stand-by the control



#### To put in stand-by the control

- press the  key for about 2 seconds  
The control goes out

 In stand-by mode the control ensures an antifreeze safety. In case of temperature  $<5\text{ }^{\circ}\text{C}$ , the hot water solenoid valve outputs and boiler consent are activated automatically.

### 5.4.3 Set room temperature

#### To set-up the temperature

- operate the   keys to decrease or increase the desired value  
The displayed value change

 The adjustment range goes from  $16\text{ }^{\circ}\text{C}$  to  $28\text{ }^{\circ}\text{C}$ , with a resolution of  $0,5\text{ }^{\circ}\text{C}$ .

 Out of range values from  $5\text{ }^{\circ}\text{C}$  and  $40\text{ }^{\circ}\text{C}$  are allowed, except in automatic mode. These values should be set only for short periods of time.

### 5.4.4 Automatic operation

#### To select the Automatic function

- press the **AUTO** key for about 2 seconds  
The symbol **A** on indicates the Automatic function enable

⚠ The ventilation speed is automatically adjusted between a minimum value and a maximum value based on an algorithm type PI, according to the actual distance from the room temperature set-point.

### 5.4.5 Silent operation

#### To select the Silent operation

- press the **Silent** key for about 2 seconds  
The symbol **S** on indicates the Silent function enable

⚠ The ventilation speed is limited at a more reduced maximum value.

### 5.4.6 Night function

#### To select the Night function

- press the **Night** key for about 2 seconds  
The symbol **N** on indicate the Night function enable

⚠ The ventilation speed is limited at a very low value.

⚠ The set temperature changes automatically:

- in heating function decreases by 1 °C after one hour and by another degree after 2 hours
- in cooling function decreases by 1 °C after one hour and by another degree after 2 hours

### 5.4.7 Maximum ventilation speed

#### To select the operation at the maximum ventilation speed

- press the **Max** key for about 2 seconds  
The symbol **M** on indicates the maximum speed function enable

⚠ Maximum power output is immediately obtained both in heating and cooling.

⚠ After reaching the desired room temperature, select a different function to increase the thermal and acoustic comfort.

## 5.5 Warnings

### 5.5.1 Long period shut-down

For seasonal shutdowns or for long periods:

- disable the device
- set the main system switch to Off

⚠ The antifreeze function is not on.

### 5.5.2 Error signals

⚠ **E1** Room temperature probe failure located inside the thermostat

⚠ **E2** Failure or connection of a double remote room probe on one of the connected device

### 5.4.8 Set the key lock

#### To set-up the key locking

- press both **Lock** keys for 2 seconds  
The text **KL** appearing on the display

⚠ All settings are inhibited by the user.

⚠ Repeat the sequence to unlock the control.

### 5.4.9 Brightness reduction

#### To reduce the display brightness

- press the **Bright** key for 5 seconds  
The text **BR** appearing on the display
- press the **Down** key to decrease the value, wait 20 seconds

⚠ After 20 seconds from the last action the panel brightness will be reduced to increase the comfort during night use. On the display will appear only the room temperature.

### Deactivation

#### To deactivate the display

- press the key **Power** for about 2 seconds  
All the light signals go off

⚠ In stand-by mode the control ensure an antifreeze safety.

### 5.4.11 Room temperature probe offset adjustment

#### To adjust the room temperature probe offset

- from display off, hold the key **Offset** for about 5 seconds  
Access to the variation menu of the AIR probe offset displayed on the display

⚠ Use this adjustment carefully.

⚠ This adjustment must be carried out only after having found actual deviations from the room temperature using a reliable tool.

⚠ Adjust the measured value within a range of +/- 10 °C in steps of 0,1 °C.

⚠ After 20 seconds from the last action the control goes out and the settings is memorized.

# WALL-MOUNTED CONTROL B3V151 - B3V152

## 6.1 Electric connections

### 6.1.1 Connection diagram

#### B3V151

1. PCB
2. Wall control

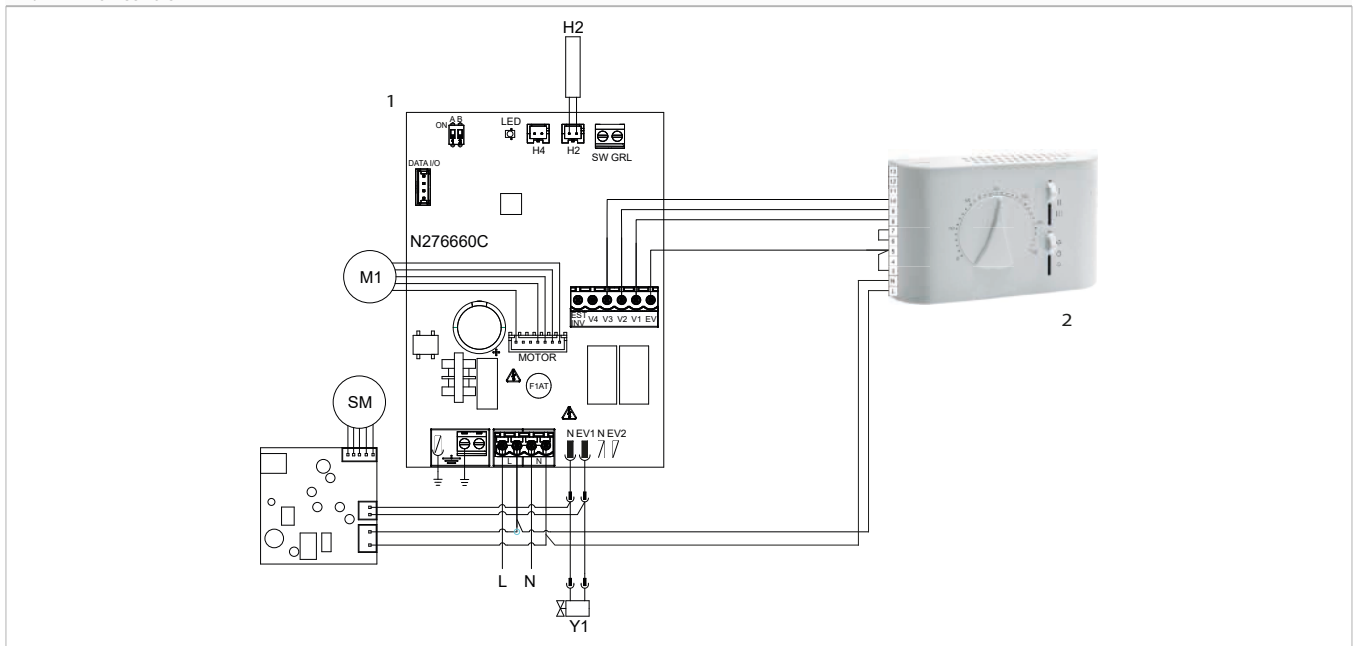

#### B3V152

1. PCB
2. Built-in wall control

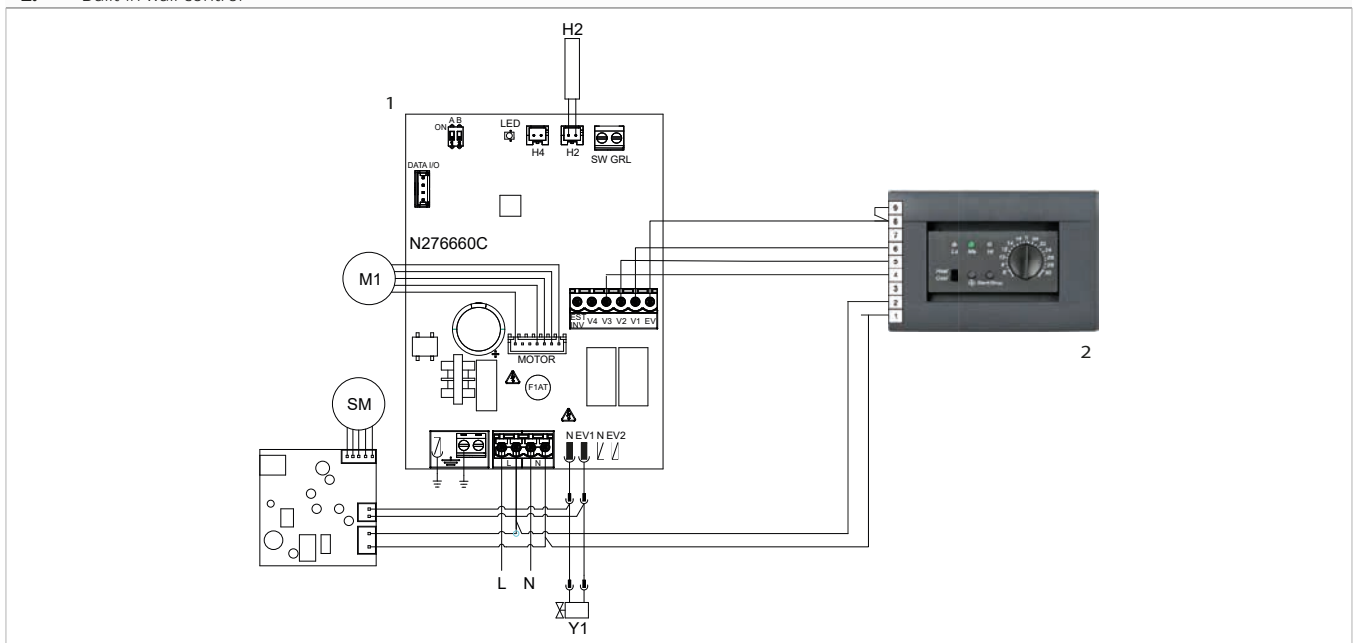

## MAINTENANCE

### 7.1 Routine maintenance

Routine maintenance is essential to keep the device always efficient, safe and reliable over time.

It can be done:

- every six months

**Before each cleaning and maintenance intervention:**

- disconnect the device from the power mains by turning the system master switch to "OFF"

- ⚠ Wait for the components to cool down in order to avoid any burns.
- ⚠ After completing the maintenance work, must be restored the original condition.
- ⊖ It is forbidden to open the access doors and carry out any technical or cleaning intervention, before having disconnect the device from the mains supply by placing the main switch of the system on "OFF".

**⚠ Warnings:**

- Do not lean or sit on the fancoil to avoid damaging the appliance.
- Do not manually move the horizontal louver of the air outlet. Always use the remote control to do this operation.
- If water leaks from the device, you must switch it off immediately and disconnect the power supply. Then, call the nearest customer service centre.
- The device must not be installed in rooms where there are explosive gases or where there are conditions of humidity and temperature out of the limits defined in the installation manual.
- Clean the filter regularly.

### 7.2 Six-monthly operations

#### 7.2.1 External cleaning

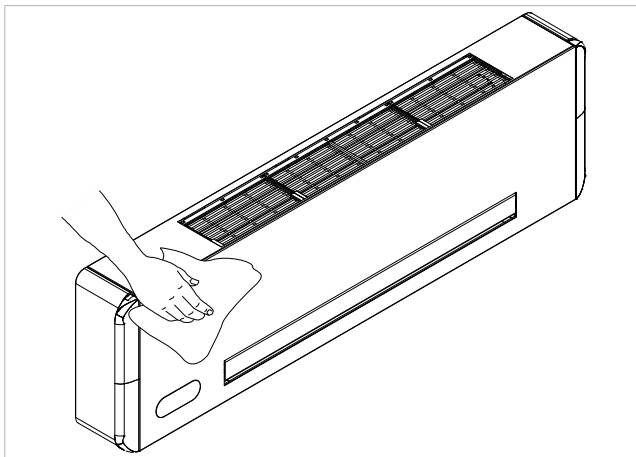

Clean the external surfaces using a soft cloth dampened with water.

- ⚠ Do not use abrasive sponges or abrasive or corrosive detergents as you might damage the painted surface.

#### 7.2.2 Air intake filter cleaning

Cleaning the filter must be carried out:

- after prolonged operation, considered the concentration of impurities in the air,
- when you plan to restart the system after prolonged disuse.

#### Filter extraction

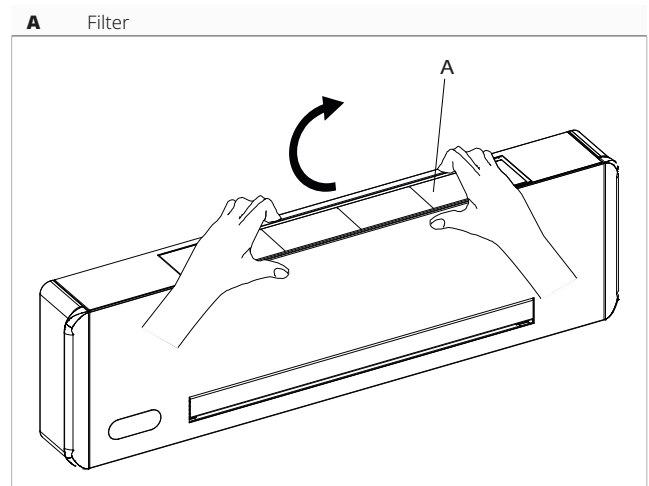

To extract the filter:

- lift it slightly
- rotate until the complete exit from the housing



- A** Filter
- B** Extraction direction

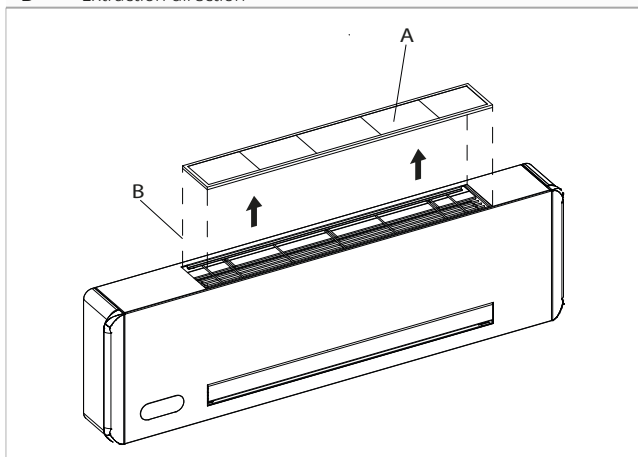

- remove the filter

### Cleaning

- A** Vacuum cleaner
- B** Long nozzle
- C** Filter

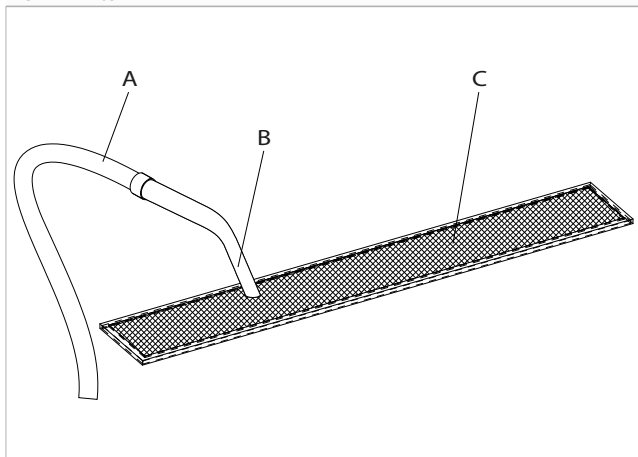

To clean the filters:  
 - to use a vacuum cleaner  
 - to aspirate dust

- A** Running water
- B** Filter

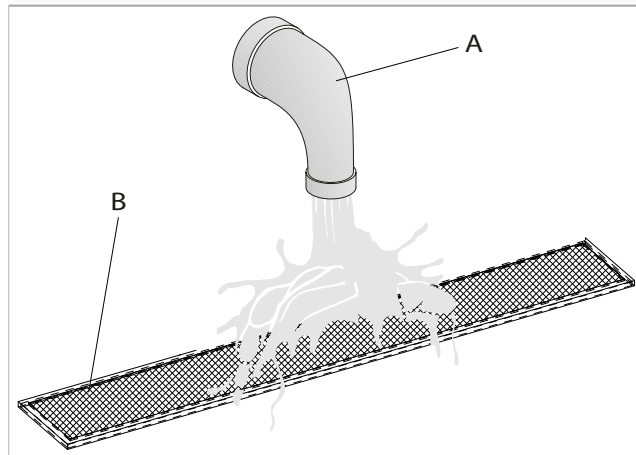

- wash the filter with running water  
 - allow it dry

**⚠** Do not use detergents or solvents to clean the filter.

### Inserting the filter

Remount the filter paying particular attention to introduce the lower flap in its housing.

**⚠** After filter cleaning check if the panel is properly mounted.

**⚠** The device features a safety switch that prevents the fan from starting if the mobile panel is incorrectly mounted or the filter are missing.

**⚠** Do not use the device without its mesh filter.

**⊖** It is forbidden to use the device without its mesh filter.

## 7.3 Suggestions for energy saving

For a correct operation of the device and a great energy saving:

- keep the filters clean
- keep the doors and windows of the locations fitted with air conditioning systems closed as much as possible
- During summer limit the entry of direct sun rays into the rooms to be air-conditioned by means of external screens (projections, curtains, shutters, etc.)

## TROUBLESHOOTING

### 8.1 Preliminary warnings

Should you encounter any of the anomalies below:

- the ventilation does not start even if the water circuit is filled with hot or cold water
- the device is losing water in heating mode
- the device is losing water in cooling mode
- the device generates excessive noise
- there is dew on the front panel

Follow the instructions below:

- disconnect the device from power supply immediately
- close the water taps
- contact immediately an authorized technical support center or qualified staff

**⚠** The interventions must be carried out by a qualified installer or by a specialized support center.

**⊘** Do not intervene personally.

### 8.2 Troubleshooting table

Effect	Cause	Solution
The ventilation is delayed with respect to the new temperature or function settings.	The circuit valve requires a certain time to open and therefore to make the hot or cold water circulate inside the device.	Wait 2 or 3 minutes to allow the circuit valve to open.
The device does not activate the ventilation.	Cold or hot water is missing from the system.	Make sure the boiler or the water cooler are on.
The ventilation does not start even if the water circuit is filled with hot or cold water.	The hydraulic valve stays closed.	Demount the body of the valve and check if the water circulation is restored. Check the valve operation feeding it separately to 230 V. If you were to turn on, the problem may be in the electronic control.
	The ventilation motor is jammed or burnt.	Check the motor windings and check if the fan rotates freely.
	The wirings are not correct.	Check the electrical connections.
The device is losing water in heating mode.	Leaks at the hydraulic connections of the system.	Check the leak and tighten the connection.
	Losses in the valve group.	Check the condition of the gaskets.
There is dew on the front panel.	Detached thermal insulation.	Check the correct positioning of the thermal and acoustic insulations paying particular attention to the front one located on top of the finned coil.
There are water drops on the air vent.	High humidity conditions (>60%) might generate condensation, especially at minimum ventilation speeds.	As soon as the level of relative humidity drops, the phenomena disappears. However, a few water drops falling inside the device will not cause any malfunction.
The device is losing water in cooling mode.	The condensate tray is clogged.	Slowly pour a bottle of water in the lower section of the battery to check the drainage; if necessary clean the tray and/or improve the slope of the drain pipe.
	The condensate discharge pipe does not have the slope required for correct drainage.	
	The connection pipes and the valves unit are not well insulated.	Check the pipe insulation.
The device generates excessive noise.	The fan touches the structure.	Verify
	The fan is unbalanced.	The unbalancing generates excessive machine vibrations: replace the fan.
	Check the filters for dirt and clean them if necessary	Clean filters

## TECHNICAL INFORMATION

### 9.1 Technical data

#### 9.1.1 2 pipes

			Filomuro		
Models	m.u.		400	600	800
<b>Cooling performances (W 7/12 °C; A 27 °C)</b>					
Total cooling capacity	(1)	kW	1,24	1,61	1,94
Sensible cooling capacity	(1)	kW	0,98	1,27	1,52
Water flow	(1)	L/h	208	279	365
Pressure drop	(1)	kPa	11,7	5,1	5,3
<b>Heating performances (W 45/40 °C; A 20 °C)</b>					
Heating capacity	(2)	kW	1,50	2,01	2,41
Water flow	(2)	L/h	260	349	451
Pressure drop	(2)	kPa	16,3	7,2	8,1
<b>Hydraulic data</b>					
Coil water content		L	0,50	0,61	0,77
Maximum operating pressure		bar	10	10	10
Hydraulic connections		" EK	3/4	3/4	3/4
Pipelines minimum diameter		mm	14	16	18
<b>Aeraulic data</b>					
Air flow at the maximum fan speed		m <sup>3</sup> /h	228	331	440
Air flow at the medium fan speed		m <sup>3</sup> /h	155	229	283
Air flow at the minimum fan speed		m <sup>3</sup> /h	84	124	138
Static pressure available		Pa	10	10	10
<b>Electrical data</b>					
Maximum absorbed current		A	0,10	0,12	0,16
Power supply		V/ph/Hz	230/1/50	230/1/50	230/1/50
Power consumption at the maximum speed		W	19	20	29
Power consumption at the minimum speed		W	5	5	5
Power conductor (phase+neutral)		mm <sup>2</sup>	1,5	1,5	1,5
protective conductor section on ground		mm <sup>2</sup>	1,5	1,5	1,5
Circuit breaker		A	2	2	2
<b>Sound data</b>					
Maximum sound power level		dB(A)	53	54	55

1. Water temperature in 7 °C, Water temperature out 12 °C, Room temperature 27 °C b.s. e 19 °C b.u. Performances according to EN 1397  
 2. Water temperature in 45 °C, Water temperature out 40 °C, Room temperature 20 °C b.s. e 15 °C b.u. Performances according to EN 1397  
 3. Sound pressure measured at a distance of 1 meter according to ISO 7779

Models		m.u.	Filomuro		
			400	600	800
Sound pressure level at maximum air flow	(3)	dB(A)	40	41	42
Sound pressure level at medium air flow	(3)	dB(A)	33	34	34
Sound pressure level at minimum air flow	(3)	dB(A)	25	25	26
<b>Operating limits</b>					
Minimum water inlet temperature		°C	4	4	4
Maximum water inlet temperature		°C	80	80	80
1. Water temperature in 7 °C, Water temperature out 12 °C, Room temperature 27 °C b.s. e 19 °C b.u. Performances according to EN 1397 2. Water temperature in 45 °C, Water temperature out 40 °C, Room temperature 20 °C b.s. e 15 °C b.u. Performances according to EN 1397 3. Sound pressure measured at a distance of 1 meter according to ISO 7779					

## 9.2 Dimensions

### 9.2.1 2 pipes

#### Filomuro

Models		m.u.	Filomuro		
			400	600	800
Total width		mm	927	1127	1327
Total height		mm	335	335	335
Total depth		mm	128	128	128
Net weight		kg	14,0	16,0	19,0

- A** Lateral view  
**B** Front view

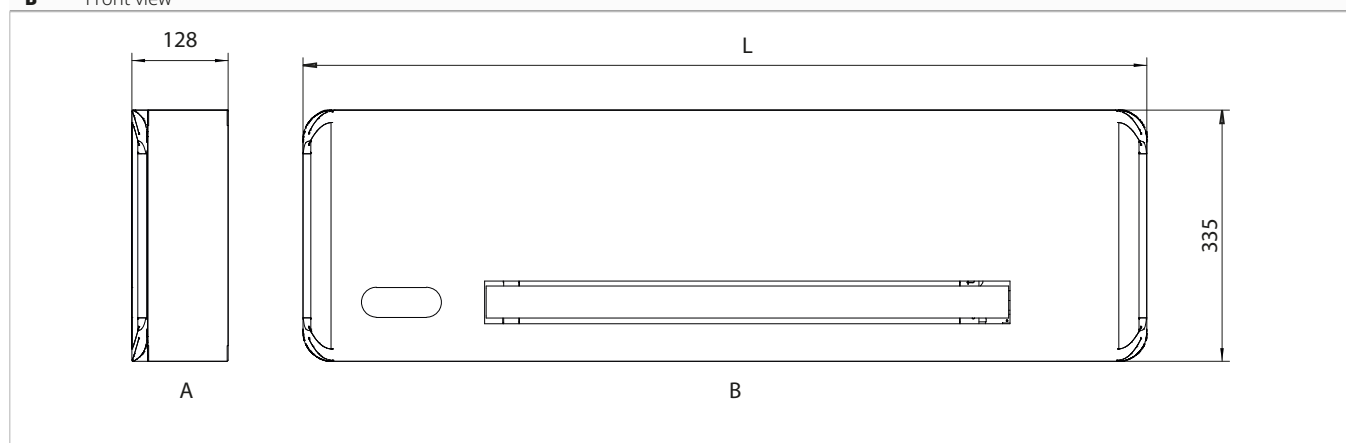









**innova**

INNOVA S.r.l.  
Via I Maggio 8 - 38089 Storo (TN) - ITALY  
tel. +39.0465.670104 - fax +39.0465.674965  
info@innovaenergie.com