

UTEK[®]



DUO DP



DUO DP



- ◆ Heat recovery ventilator configurable on site with cross-flow aluminium heat exchanger
- ◆ Suitable solution for ventilation of commercial buildings
- ◆ Double skin steel panels, thickness 25mm
- ◆ Centrifugal fans direct driven motors
- ◆ Versions available:
 - with water or electric post-heating integrable into the unit:
 - Without regulation or
 - Plug-n-play versions with electrical panel pre-wired and microprocessor control mounted on board.
 - Optional microprocessor controllers:
 - EVO PH
 - EVO D PH (with Modbus communication protocol)

DESCRIPTION

- ◆ Extruded aluminium profile structure with rounded corners
- ◆ double skin steel panels, plasticized white, sandwiched on injected polyurethane foam insulation, thickness 25mm
- ◆ side/beneath access for inspection and maintenance
- ◆ pressure sockets to measure the filters loss of pressure
- ◆ condensation drainage system

VENTILATORS

- ◆ 3 or 4 speed direct driven AC blowers 230V-1-50Hz (up to size 4)
- ◆ 1 speed direct driven AC blowers 400V-3-50Hz (for size 5 and 6)

HEAT EXCHANGER

- ◆ High efficiency cross-flow aluminium heat exchanger, removable from beneath (for horizontal configuration) or from the side (for vertical configuration)

FILTERS

- ◆ G4 for exhaust air
- ◆ F7 low pressure loss for fresh air

RANGE

- ◆ Nr. 6 models from 400 m³/h up to 5.600 m³/h
- ◆ high values of pressure available to the ducting

CONFIGURATIONS AVAILABLE

- ◆ Horizontal with or without motorized by-pass
- ◆ vertical with or without motorized by-pass

ACCESSORIES AVAILABLE ON REQUEST (see the Accessories booklet)

- ◆ **Speed control (only for coupling to the unit without regulation):**
 - CV4 4 speed switch commutator for 230V-1-50Hz motors
 - CV3 3 speed switch commutator for 230V-1-50Hz motors
 - RVT6A and RVT 9A speed regulator for 400V-3-50Hz motors
- ◆ **Accessories of deicing or post-heating for duct mounting:**
 - RCFE-SCT electric heater with electronic regulation
 - RCF-SCTTC electric heater with thermostatic regulation
 - BA-AC post-heating hot water coil 80°/70°C
 - BA-AT post-heating temperature water coil 45°/35°C
- ◆ **Accessories of cooling for duct mounting:**
 - BA-AF cooling water coil with insulated plenum - *Contact the technical office*
- ◆ **Optional sensors:**
 - EE80 CO₂ sensor
 - QPA 2002 CO₂/VOC air quality sensor
 - EE16 Humidity sensor
- ◆ **Accessories for air filtration:**
 - F9 optional filter low pressure loss
- ◆ **Protective accessories:**
 - SKMF-R weather protection cowl
 - T weather protective roof
- ◆ **Cleaning and sanitation:**
 - AIRCO-GEL
 - AIRCO-SPRAY
 - AIRCO CLEAN

PRICE LIST

See the Price list booklet



PERFORMANCES

DUO 1 DP | 4 speed

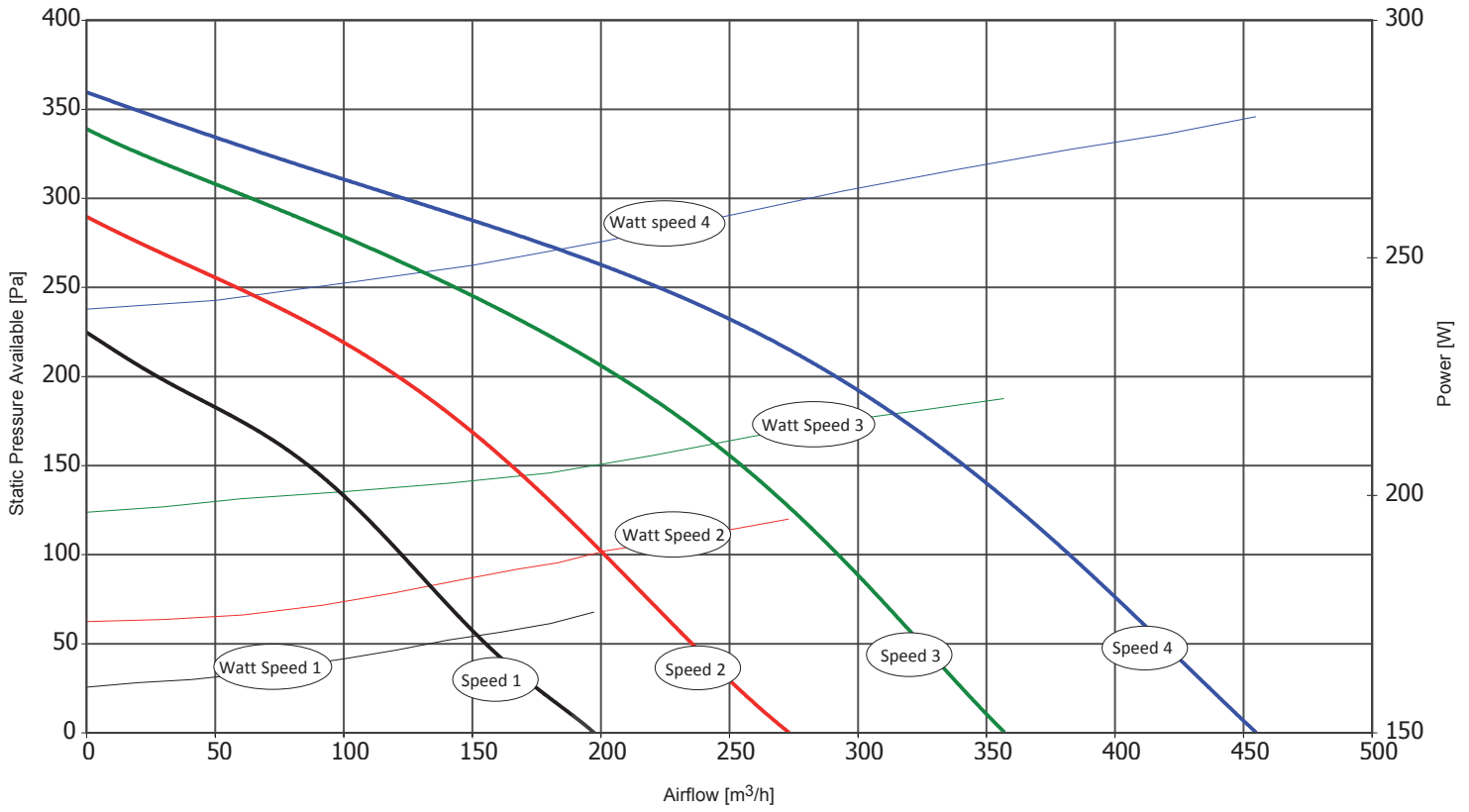

The unit must be ducted properly: UTEK authorizes the use only according to its performance diagram shown into this catalogue.
 The claimed performances are guaranteed only by UTEK original filter low pressure loss.

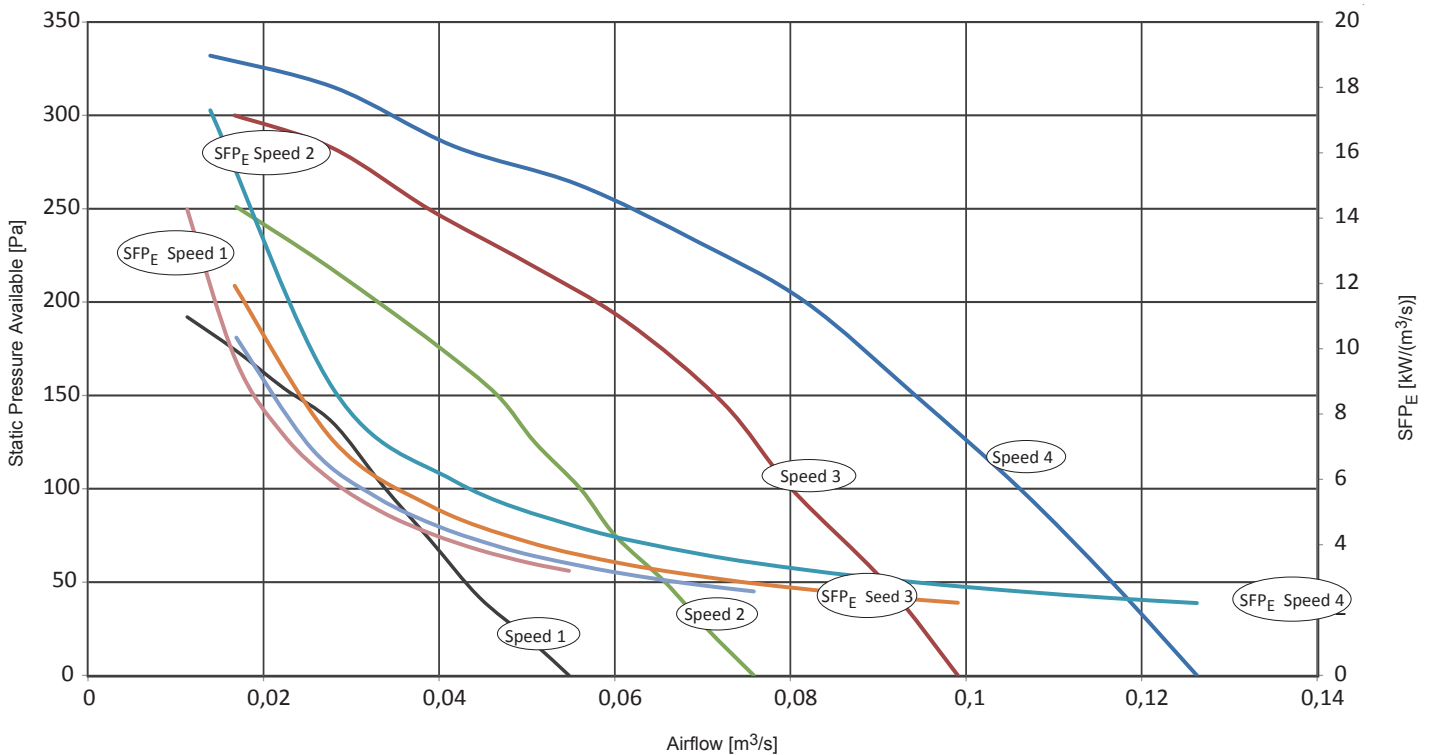

The unit must be ducted properly: UTEK authorizes the use only according to its performance diagram shown into this catalogue.
 The claimed performances are guaranteed only by UTEK original filter low pressure loss.



PERFORMANCES

DUO 2 DP | 4 speed

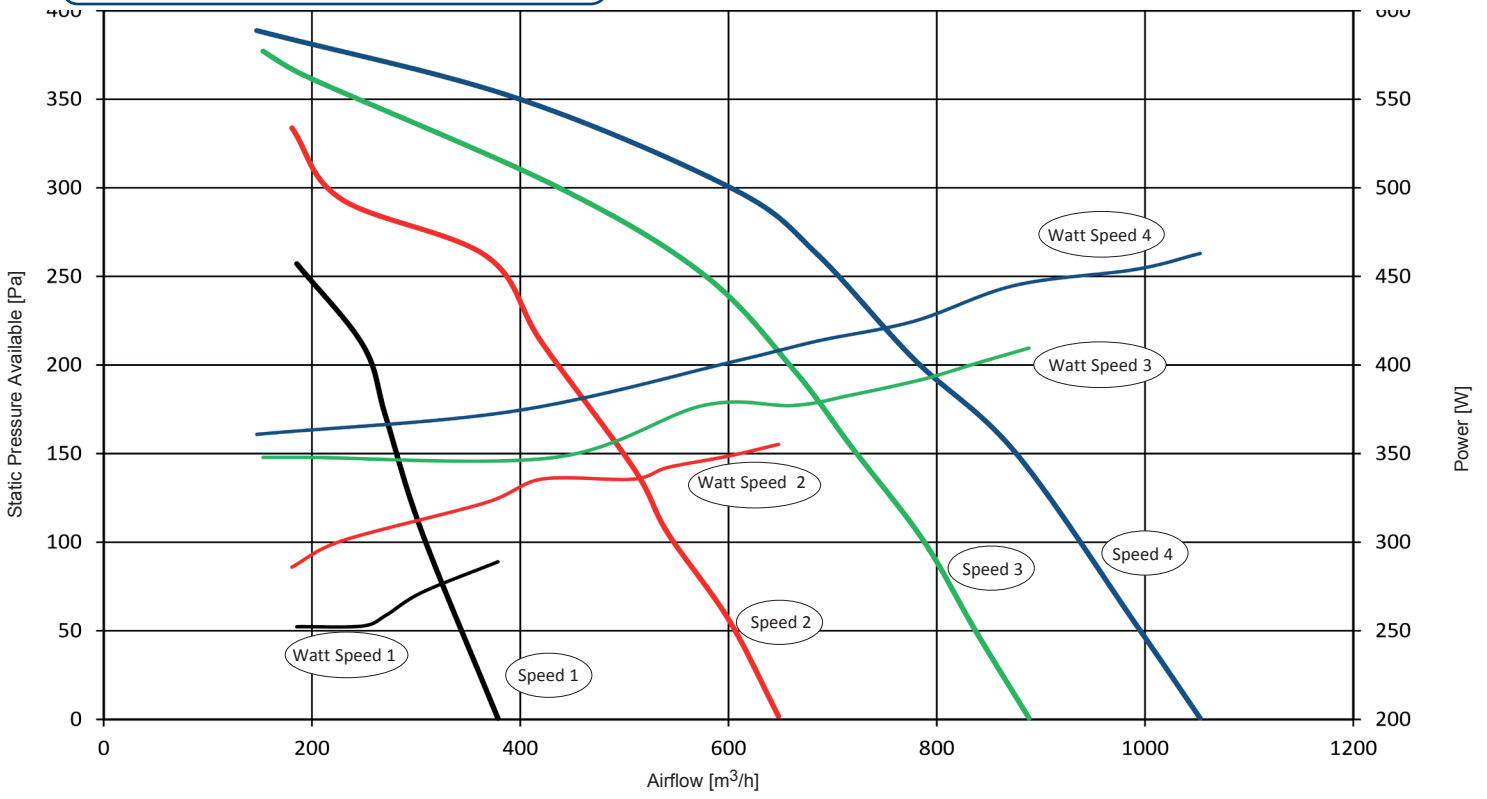

The unit must be ducted properly: UTEK authorizes the use only according to its performance diagram shown into this catalogue.
 The claimed performances are guaranteed only by UTEK original filter low pressure loss.

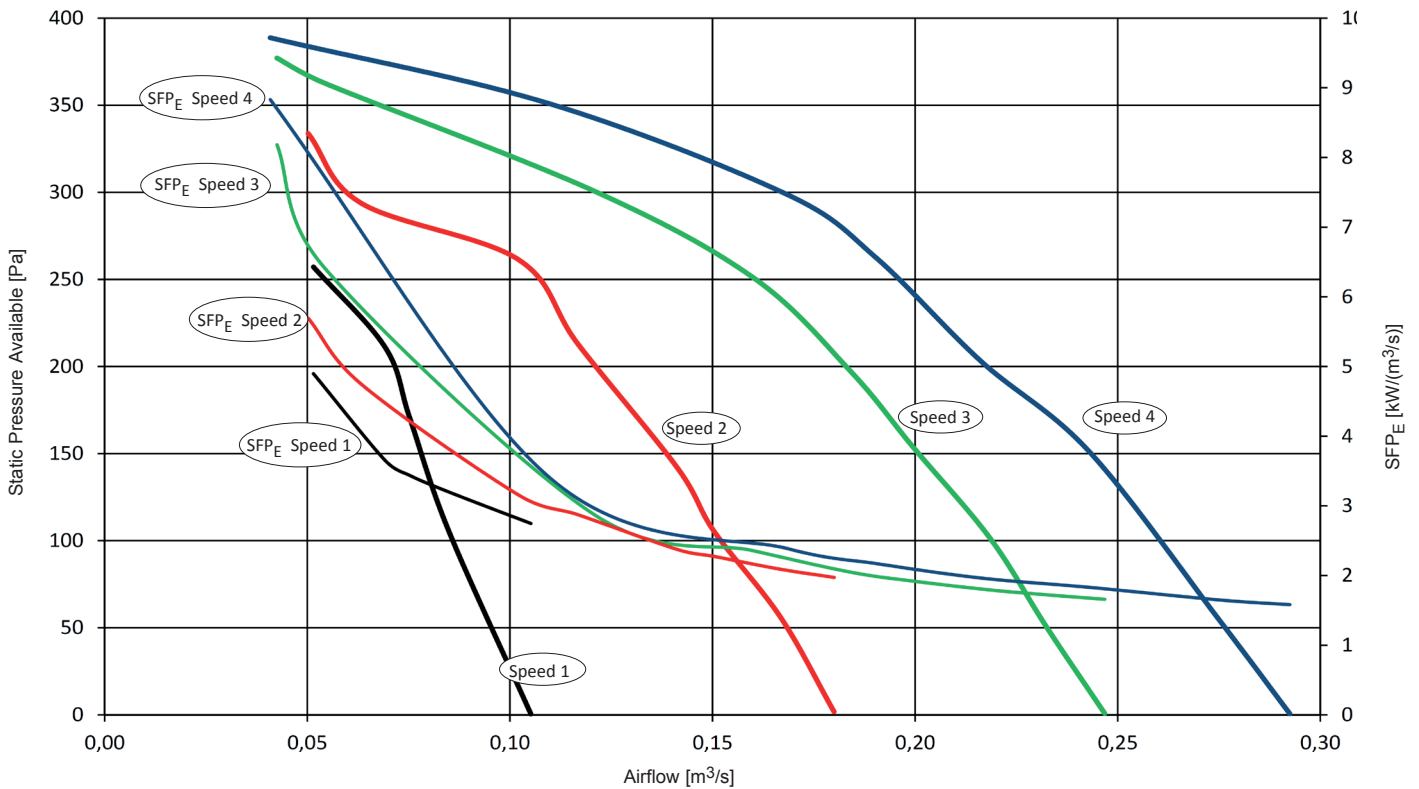

The unit must be ducted properly: UTEK authorizes the use only according to its performance diagram shown into this catalogue.
 The claimed performances are guaranteed only by UTEK original filter low pressure loss.



PERFORMANCES

DUO 3 DP | 3 speed

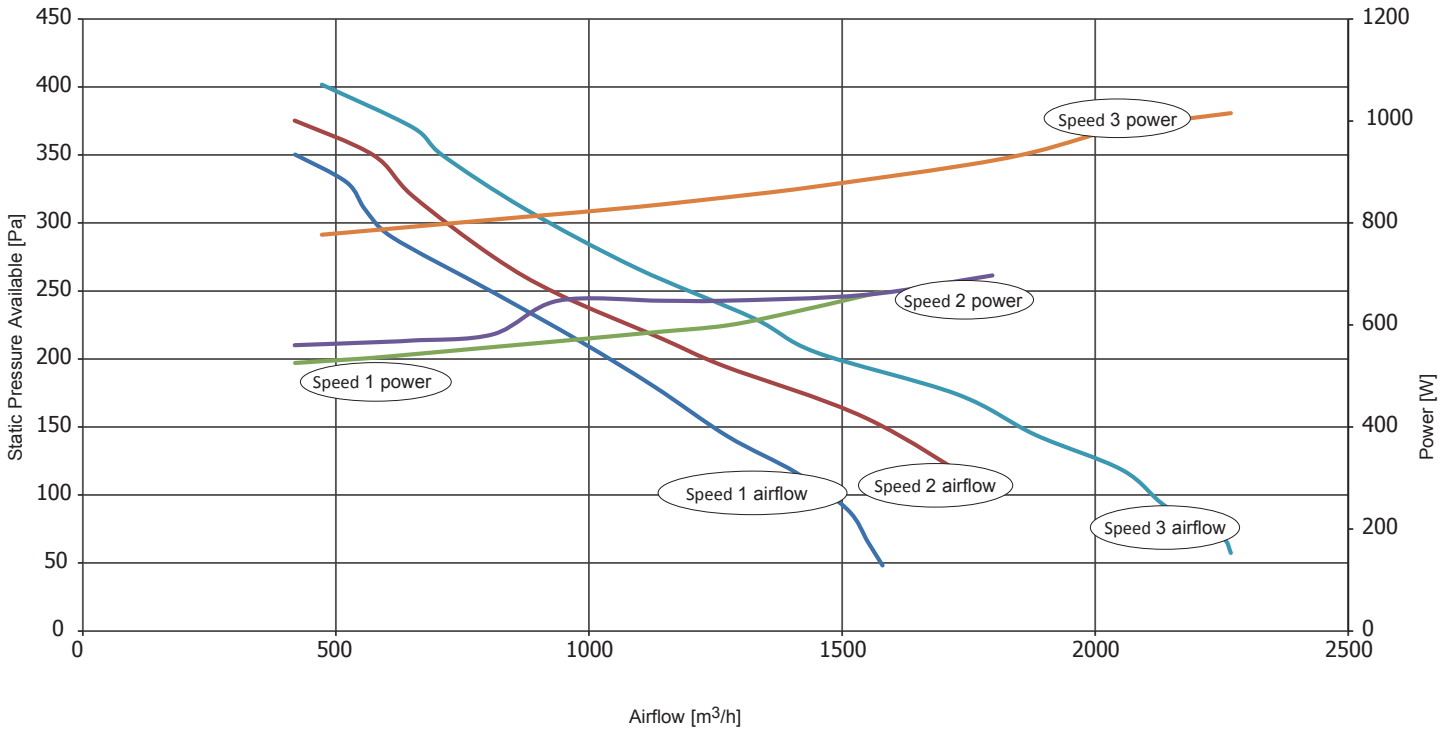

The unit must be ducted properly: UTEK authorizes the use only according to its performance diagram shown into this catalogue.
The claimed performances are guaranteed only by UTEK original filter low pressure loss.

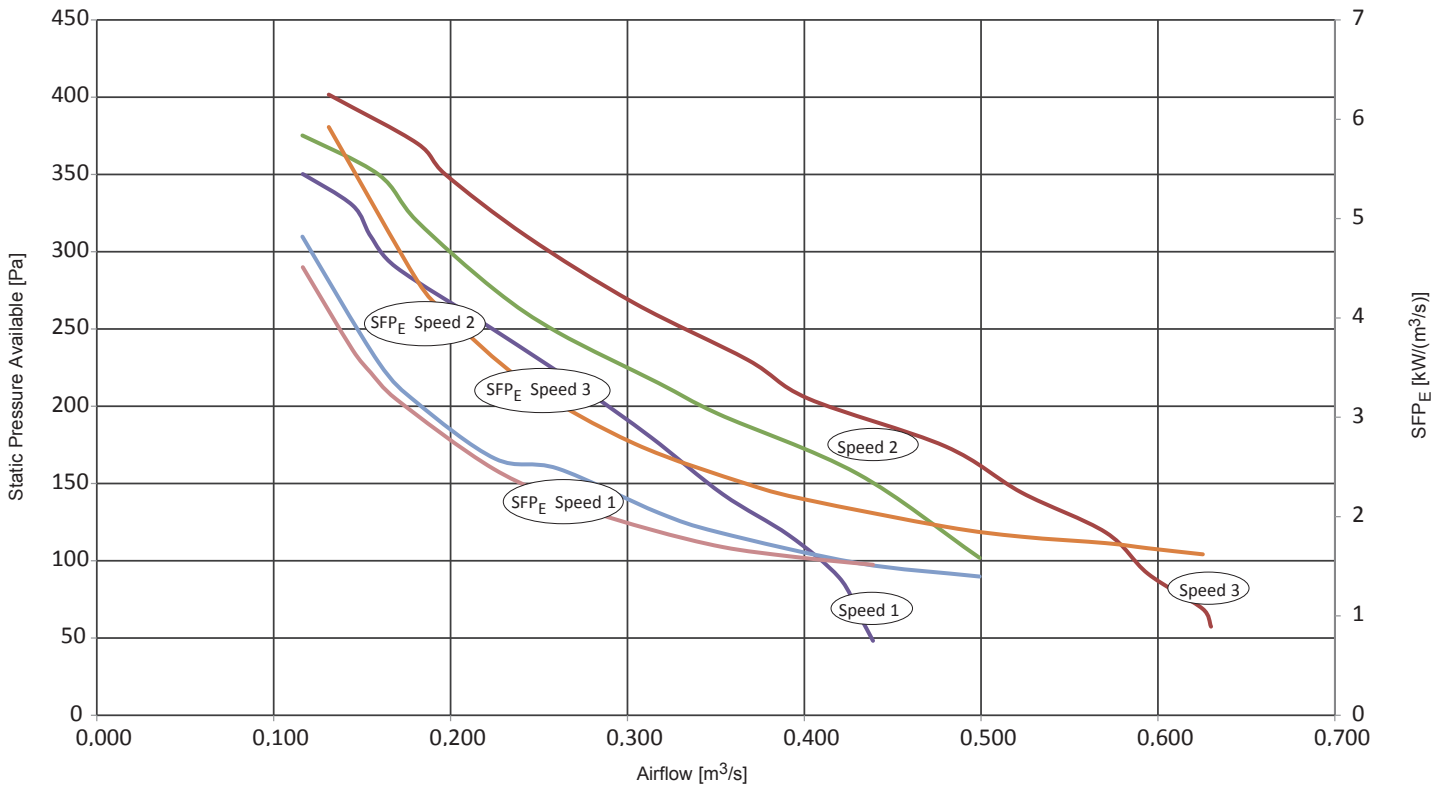

The unit must be ducted properly: UTEK authorizes the use only according to its performance diagram shown into this catalogue.
The claimed performances are guaranteed only by UTEK original filter low pressure loss.



PERFORMANCES

DUO 4 DP | 3 speed

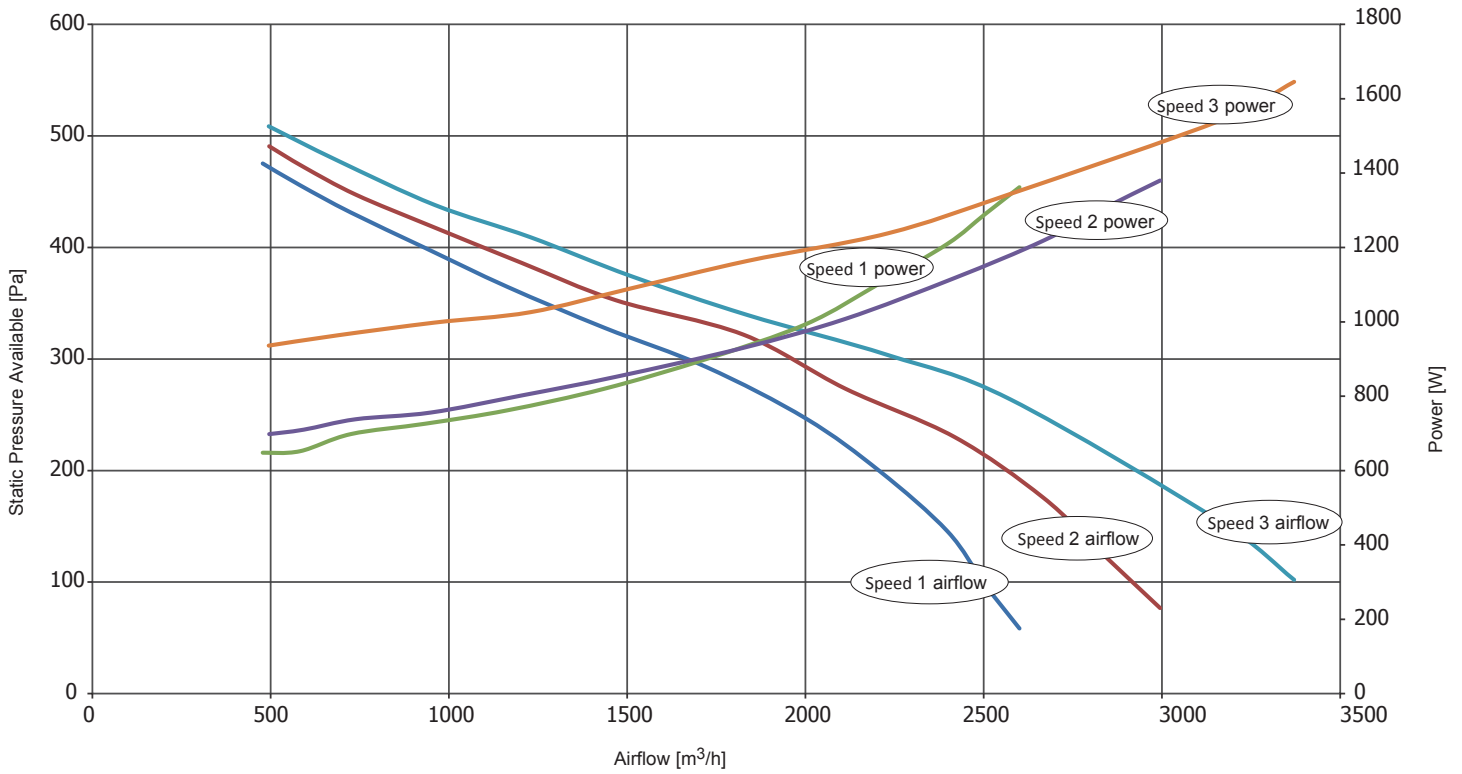

The unit must be ducted properly: UTEK authorizes the use only according to its performance diagram shown into this catalogue.
The claimed performances are guaranteed only by UTEK original filter low pressure loss.

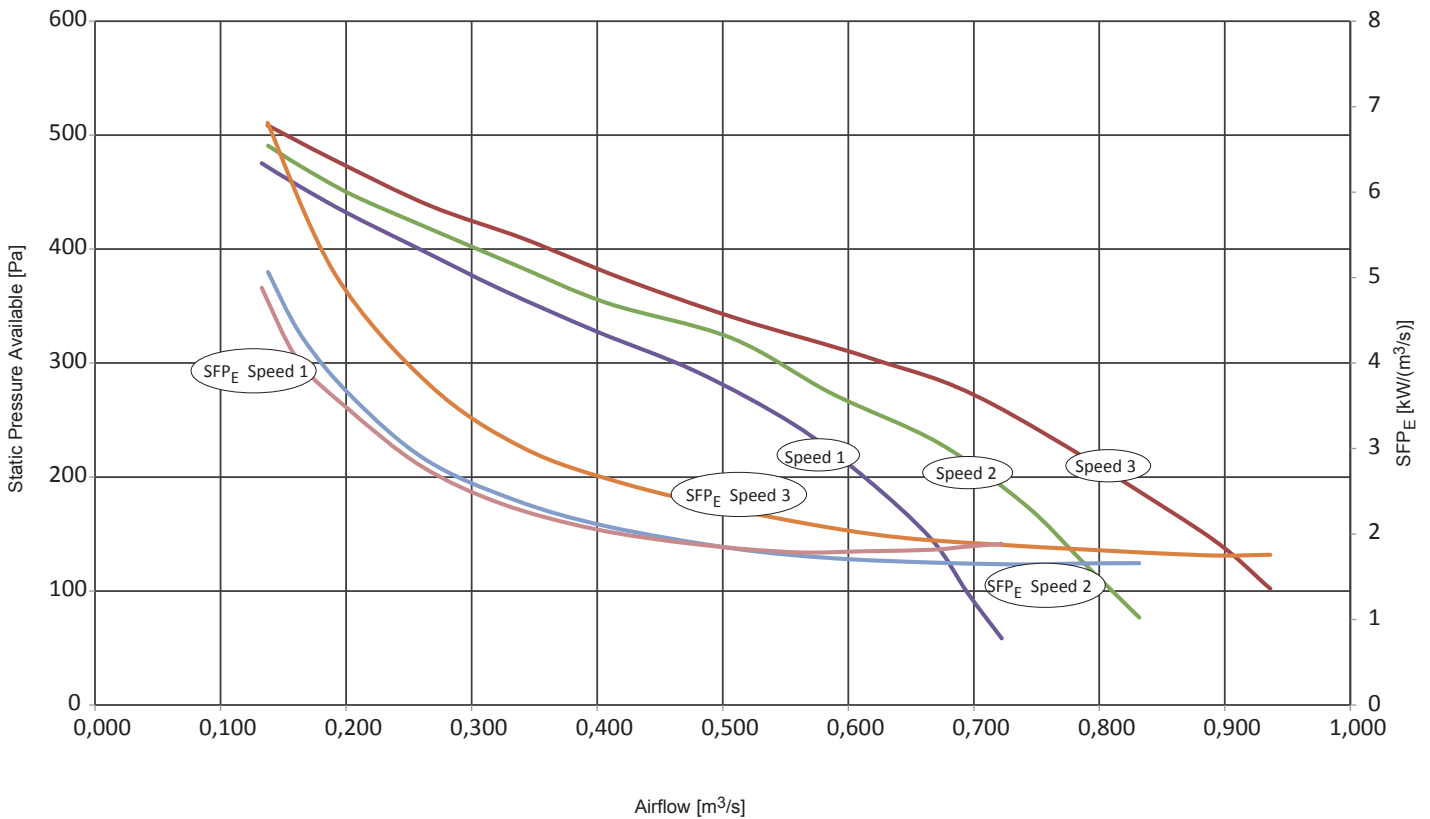

The unit must be ducted properly: UTEK authorizes the use only according to its performance diagram shown into this catalogue.
The claimed performances are guaranteed only by UTEK original filter low pressure loss.



PERFORMANCES

DUO 5 DP | 1 speed

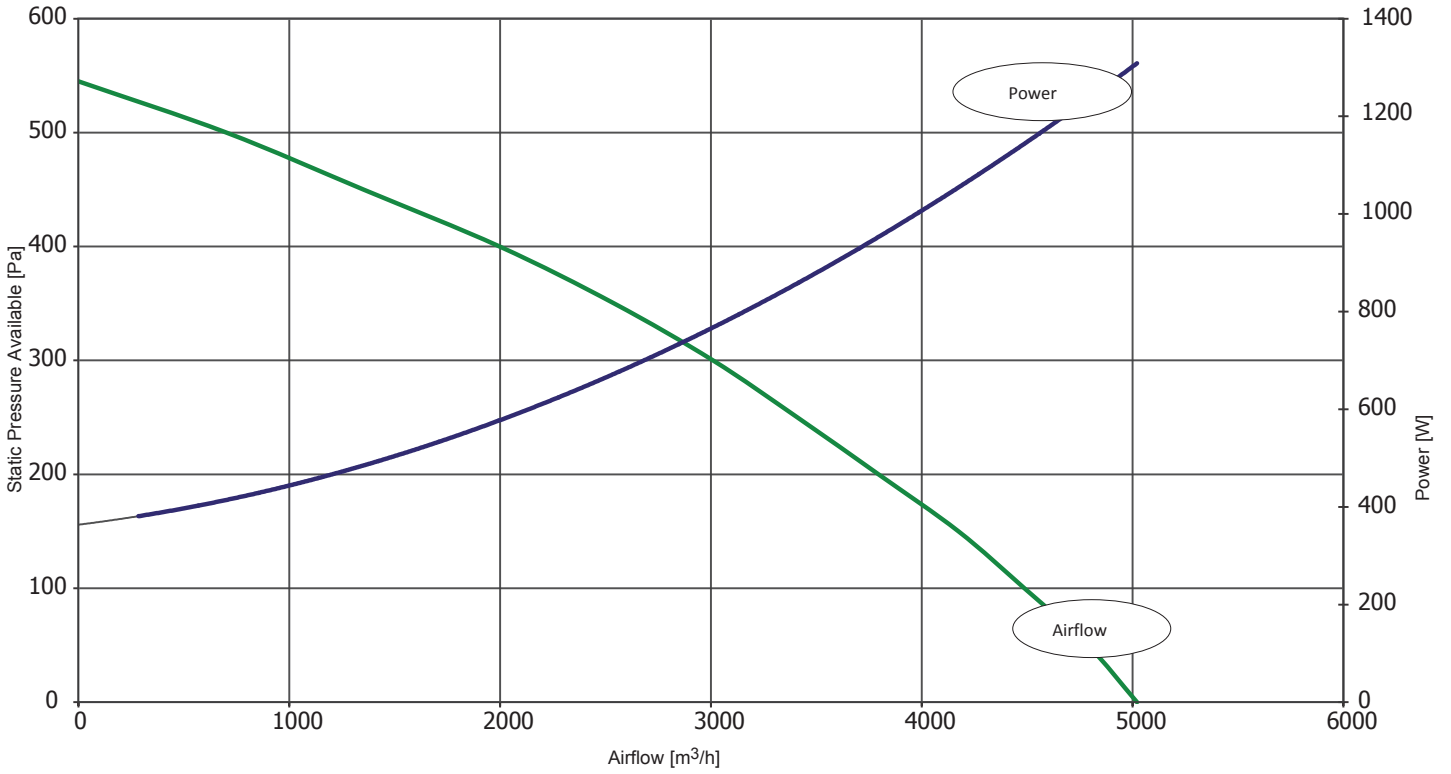

The unit must be ducted properly: UTEK authorizes the use only according to its performance diagram shown into this catalogue.
 The claimed performances are guaranteed only by UTEK original filter low pressure loss.

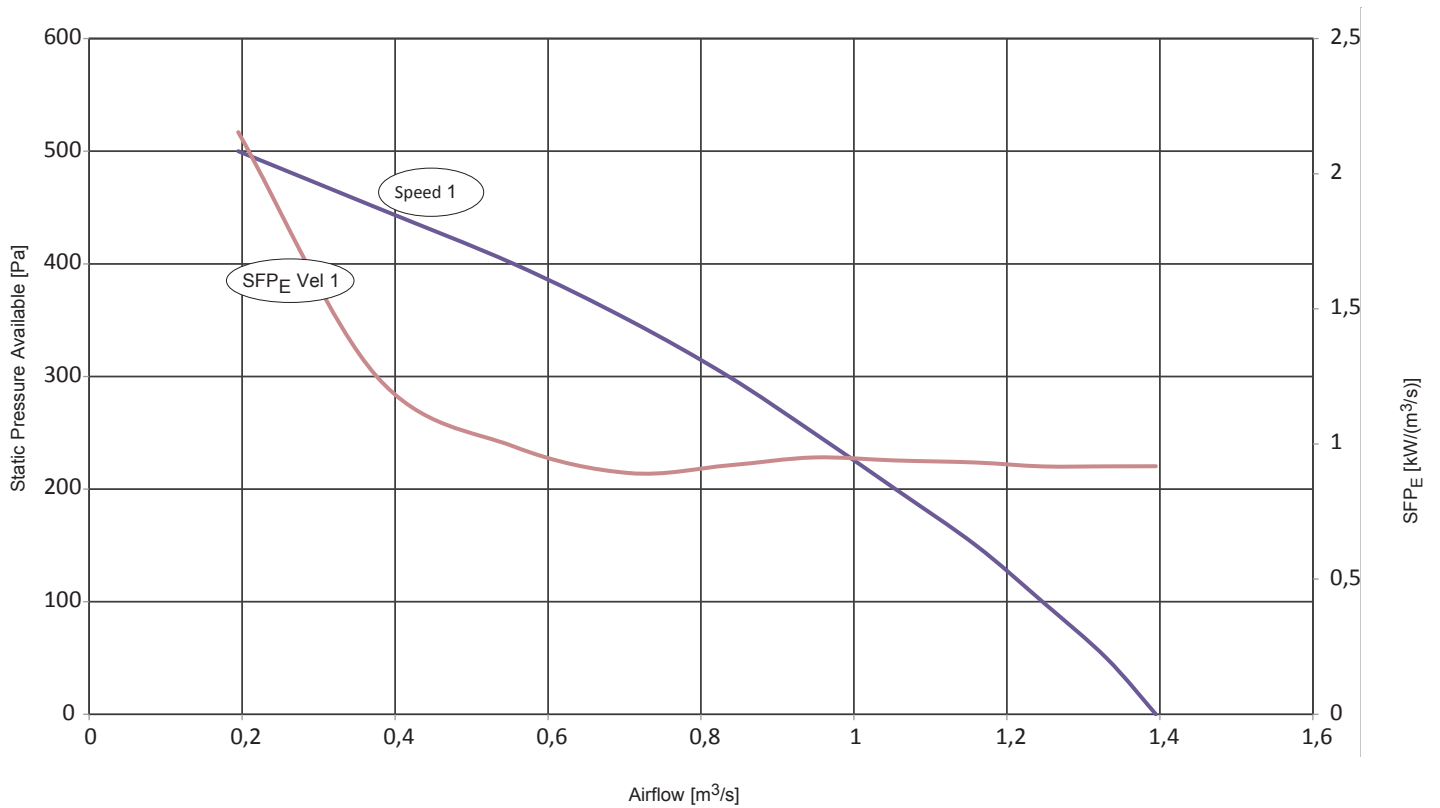

The unit must be ducted properly: UTEK authorizes the use only according to its performance diagram shown into this catalogue.
 The claimed performances are guaranteed only by UTEK original filter low pressure loss.



PERFORMANCES

DUO 6 DP | 1 speed

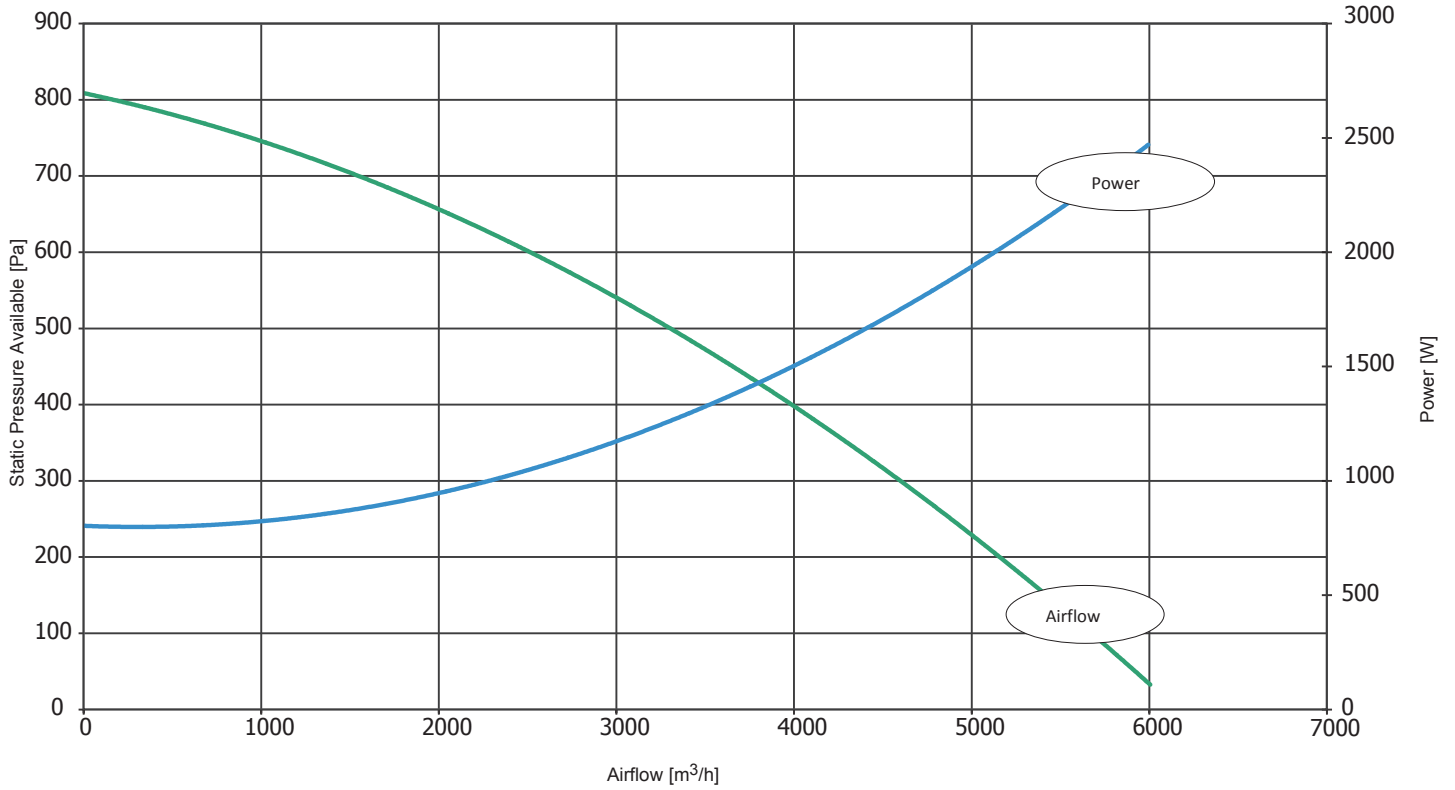

The unit must be ducted properly: UTEK authorizes the use only according to its performance diagram shown into this catalogue.
 The claimed performances are guaranteed only by UTEK original filter low pressure loss.

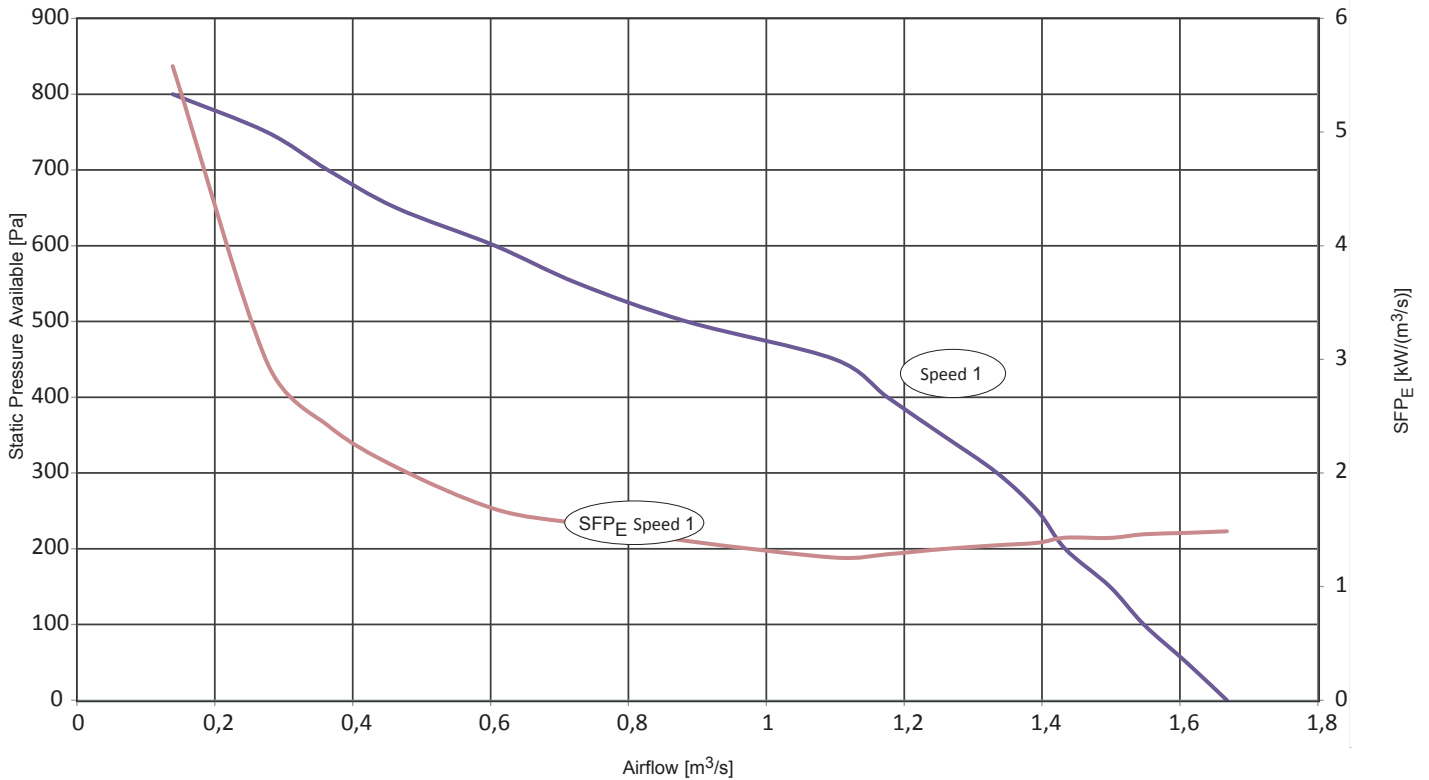

The unit must be ducted properly: UTEK authorizes the use only according to its performance diagram shown into this catalogue.
 The claimed performances are guaranteed only by UTEK original filter low pressure loss.



HEAT RECOVERY PERFORMANCE (sensible efficiency)

Values referred to the following conditions: T_{bs} external air - 5°C; U.R. external 80%; T_{bs} environment 20°C; U.R. environment 50%; nominal airflow

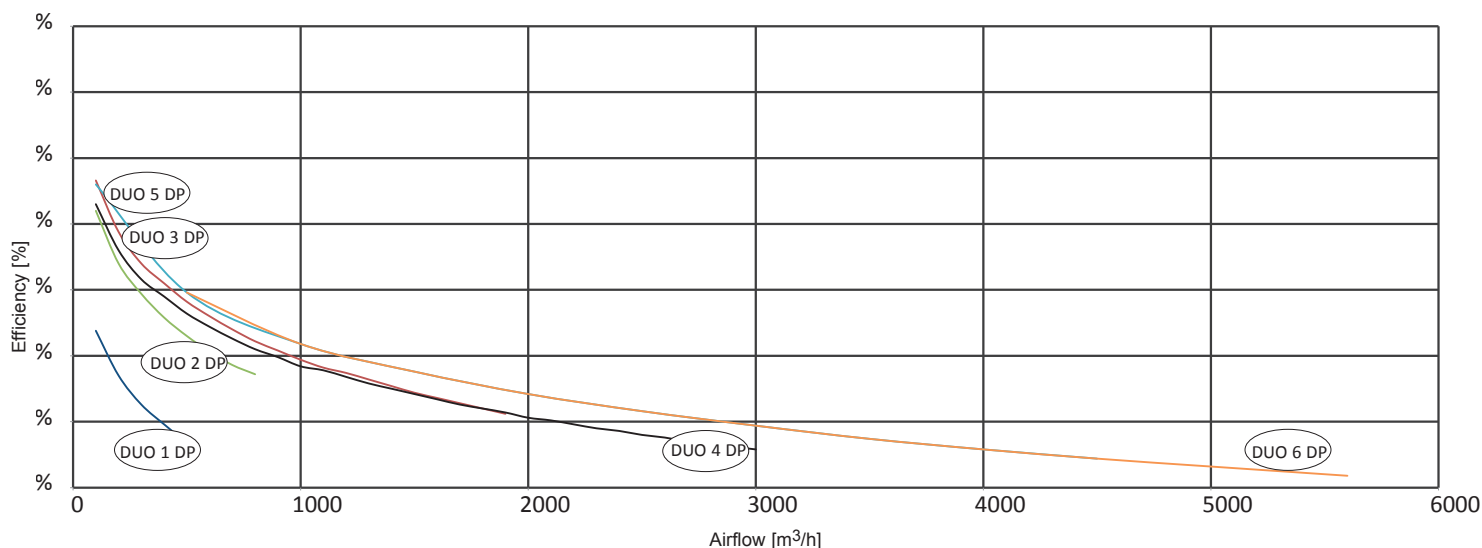

TECHNICAL DATA

	DUO 1 DP	DUO 2 DP	DUO 3 DP	DUO 4 DP	DUO 5 DP	DUO 6 DP
Nominal airflow (m³/h)	400	800	1900	3000	4500	5600
Available static pressure (Pa)*	85	190	140	180	100	120
Max. current absorption (A)	1,32	2,1	5,5	8	6,2	11,20
VENTILATORS						
Installed power (W)	150x2	290x2	373x2	550x2	750x2	1500x2
Poles (nr.)	2	4	4	4	4	4
Max. current absorption (A)	0,66x2	1,28x2	2,75x2	4x2	3,1x2	5,6x2
Fan speed	4	4	3	3	1	1
Protection level (IP)	20	20	20	20	55	55
Insulation class	F	F	F	F	F	F
Electrical power supply (V/ph/Hz)	230V-1-50Hz	230V-1-50Hz	230V-1-50Hz	230V-1-50Hz	400V-3-50Hz	400V-3-50Hz
FILTERS						
Filtration class for exhaust air	G4	G4	G4	G4	G4	G4
Filtration class for fresh air	F7	F7	F7	F7	F7	F7

* Values referring to the nominal airflow having overcome the loss of pressure of the recovery unit and filters

** Values referring to the following conditions: T_{bs} ext. air.=-5°C; T_{bs} environment=20°C; U.R. environment= 50%; Nominal airflow



TECHNICAL DATA

RCF.. ELECTRICAL HEATER OF DEICING

	DUO 1 DP	DUO 2 DP	DUO 3 DP	DUO 4 DP		DUO 5 DP	DUO 6 DP
Nominal power (kW)	2	4	6	8	8	12	12
Voltage (V)	230	230	230	230	400	400	400
Phases (nr.)	1	1	1	1	3	3	3
Stages (nr.)	1	2	2	2	2	2	2
Current absorption (A)	8,5	17,5	26	34,78	12,17	31,6	31,6
Intake air temp. on exchanger (°C)	-3	-3	0	-5	-5	-5	-5

Measured with external air temp. = -15°C nominal airflow

RCF.. ELECTRICAL HEATER OF POST-HEATING

	DUO 1 DP	DUO 2 DP	DUO 3 DP	DUO 4 DP		DUO 5 DP	DUO 6 DP
Nominal power (kW)	2	4	6	8	8	12	12
Voltage (V)	230	230	230	230	400	400	400
Phases (nr.)	1	1	1	1	3	3	3
Stages (nr.)	1	2	2	2	2	2	2
Current absorption (A)	8,5	17,5	26	34,78	11,55	17,32	17,32
Intake air temp. on exchanger (°C)	20	20	21	20	20	22	20

Measured with intake air temp. = 8°C and nominal airflow

Loss of pressure between 2 and 10 Pa, on the air side of the RCF section

BA-AC POST-HEATING HOT WATER COIL 80°/70° C

	DUO 1 DP	DUO 2 DP	DUO 3 DP	DUO 4 DP	DUO 5 DP	DUO 6 DP
Rows (nr.)	2	2	2	2	2	2
Thermal yield (kW)	2,62	5,75	10,67	14,29	30	34,5
Replacement air outlet temp. (°C)	23,3	29,2	24,4	21,9	29	25,4
Air side pressure loss (Pa)	16	32	31	27	60	100
Water side pressure loss (kPa)	1	2,5	41	21	10	10
Water side connection size (Ø)	1/2"	1/2"	1/2"	1	1	1

Values referring to the following conditions: water 80°/70°C; Intake air temp. 8°C; nominal airflow

The tables of thermal yield are available on [Accessories](#) booklet

BA-AT POST-HEATING TEMPERATE WATER COIL 45°/35° C

	DUO 1 DP	DUO 2 DP	DUO 3 DP	DUO 4 DP	DUO 5 DP	DUO 6 DP
Rows (nr.)	2	2	2	2	3	3
Thermal yield (kW)	2,2	3,7	7,9	13,3	20,6	23,4
Replacement air outlet temp. (°C)	21,0	22,2	20,3	21,2	22,1	20,5
Air side pressure loss (Pa)	90	65	95	80	90	125
Water side pressure loss (kPa)	0,9	2,1	4,9	5,7	6,1	7,0
Water side connection size (Ø)	1/2"	1/2"	3/4"	3/4"	3/4"	3/4"

Values referring to the following conditions: water 45°/35°C; Intake air temp. 8°C; nominal airflow

The tables of thermal yield are available on [Accessories](#) booklet



NOISE LEVEL

*L_w Sound level taken in accordance to UNI EN ISO 3741
(UNI EN ISO 3747 FOR DUO 5 and 6 DP models; $\Delta L_f \geq 7$ dB for each measurement position, class accuracy 2)*

DUO 1 DP	NOISE LEVEL GENERATED IN THE DUCTING (TRANSMITTED) Hz							dB(A)
	125	250	500	1000	2000	4000	8000	
L _w V ₁	37	26	18	27	15	6	5	29
L _w V ₂	44	32	24	36	24	13	8	37
L _w V ₃	49	38	30	42	32	22	16	43
L _w V ₄	54	44	35	46	39	30	25	48

	NOISE LEVEL GENERATED FROM THE CASING IRRADIATED (Hz)							dB(A)
	125	250	500	1000	2000	4000	8000	
L _w V ₁	31	22	15	23	12	5	5	25
L _w V ₂	37	27	20	31	21	11	6	32
L _w V ₃	42	32	25	36	27	19	13	37
L _w V ₄	46	37	30	39	33	26	21	41

DUO 2 DP	NOISE LEVEL GENERATED IN THE DUCTING (TRANSMITTED) Hz							dB(A)
	125	250	500	1000	2000	4000	8000	
L _w V ₁	50	48	37	45	24	25	18	47
L _w V ₂	57	56	45	51	35	35	29	53
L _w V ₃	61	60	51	54	43	42	37	58
L _w V ₄	65	63	56	56	47	45	41	60

	NOISE LEVEL GENERATED FROM THE CASING IRRADIATED (Hz)							dB(A)
	125	250	500	1000	2000	4000	8000	
L _w V ₁	53	49	35	38	19	12	8	43
L _w V ₂	57	55	42	43	26	20	13	48
L _w V ₃	61	58	46	45	33	24	15	52
L _w V ₄	63	61	47	47	36	28	17	55

DUO 3 DP	NOISE LEVEL GENERATED IN THE DUCTING (TRANSMITTED) Hz							dB(A)
	125	250	500	1000	2000	4000	8000	
L _w V ₁	65	57	60	62	58	52	44	65
L _w V ₂	68	60	62	64	60	55	48	67
L _w V ₃	67	62	64	65	62	58	51	69

	NOISE LEVEL GENERATED FROM THE CASING IRRADIATED (Hz)							dB(A)
	125	250	500	1000	2000	4000	8000	
L _w V ₁	55	48	51	53	49	44	37	56
L _w V ₂	58	51	53	54	51	47	41	58
L _w V ₃	57	53	54	55	53	49	43	59

DUO 4 DP	NOISE LEVEL GENERATED IN THE DUCTING (TRANSMITTED) Hz							dB(A)
	125	250	500	1000	2000	4000	8000	
L _w V ₁	56	50	50	48	41	31	28	52
L _w V ₂	69	59	63	64	61	57	48	68
L _w V ₃	71	71	72	75	73	70	64	79

	NOISE LEVEL GENERATED FROM THE CASING IRRADIATED (Hz)							dB(A)
	125	250	500	1000	2000	4000	8000	
L _w V ₁	48	42	43	40	35	27	23	44
L _w V ₂	58	50	54	54	52	48	41	59
L _w V ₃	60	60	61	64	62	60	55	68

DUO 5 DP	NOISE LEVEL GENERATED IN THE DUCTING (TRANSMITTED) Hz							dB(A)
	125	250	500	1000	2000	4000	8000	
L _w V _{max}	82	76	70	69	63	64	55	75

	NOISE LEVEL GENERATED FROM THE CASING IRRADIATED (Hz)							dB(A)
	125	250	500	1000	2000	4000	8000	
L _w V _{max}	78	70	64	63	57	56	42	69

DUO 6 DP	NOISE LEVEL GENERATED IN THE DUCTING (TRANSMITTED) Hz							dB(A)
	125	250	500	1000	2000	4000	8000	
L _w V _{max}	84	78	73	70	65	68	57	77

	NOISE LEVEL GENERATED FROM THE CASING IRRADIATED (Hz)							dB(A)
	125	250	500	1000	2000	4000	8000	
L _w V _{max}	80	71	65	63	57	58	43	70



**DIMENSIONS AND WEIGHT
HORIZONTAL CONFIGURATION (H)**

DIMENSIONS (mm) and WEIGHT (Kg) WITHOUT BY-PASS

MODEL	A	B	C	D	E	Ø	Weight
DUO 1 DP	640	640	345	172,5	175	200	32
DUO 2 DP	820	820	360	180	220	250	44
DUO 3 DP	1040	1040	535	315	275	315	91
DUO 4 DP	1270	1270	630	360	332,5	355	125
DUO 5 DP	1200	1300	855	427,5	305	450	171
DUO 6 DP	1200	1300	855	427,5	305	450	176

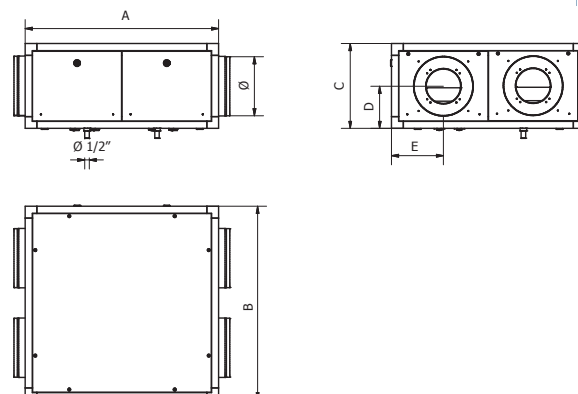

DIMENSIONS (mm) and WEIGHT (Kg) WITH BY-PASS (BP)

MODEL	A	B	C	D	E	Ø	Weight
DUO 1 DP	640	640	450	172,5	175	200	41
DUO 2 DP	820	820	465	180	220	250	56
DUO 3 DP	1040	1040	640	315	275	315	107
DUO 4 DP	1270	1270	735	360	332,5	355	146
DUO 5 DP	1200	1300	855	427,5	305	450	171
DUO 6 DP	1200	1300	855	427,5	305	450	176

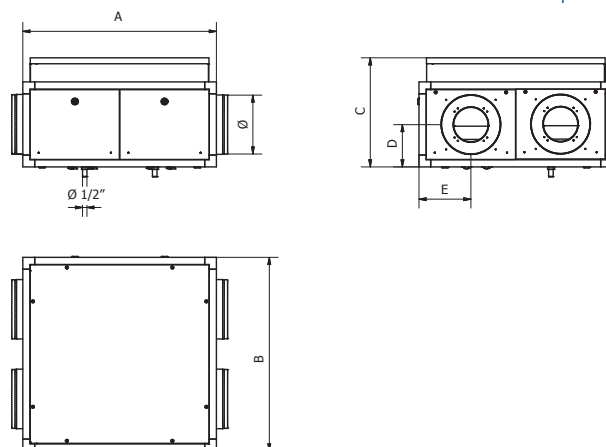

**HORIZONTAL CONFIGURATION
- top view -**

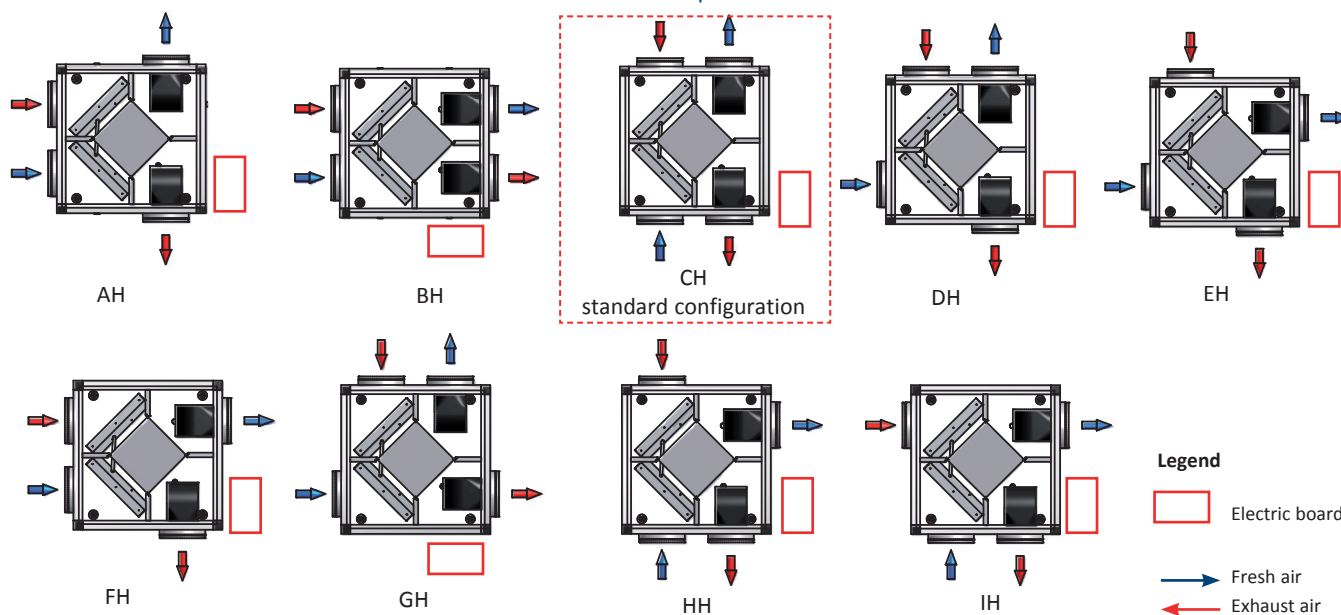



**DIMENSIONS AND WEIGHT
VERTICAL CONFIGURATION (V)**

DIMENSIONS (mm) and WEIGHT (Kg) WITHOUT BY-PASS

MODEL	A	B	C	D	E	F	Ø	Weight
DUO 1 DP	640	640	345	172,5	175	175	200	32
DUO 2 DP	820	820	360	180	220	220	250	44
DUO 3 DP	1040	1040	535	315	225	325	315	91
DUO 4 DP	1270	1270	630	360	240	425	355	125
DUO 5 DP*	1200	1300	855	427,5	305	305	450	171
DUO 5 DP**	1300	1200	855	427,5	305	305	450	171
DUO 6 DP*	1200	1300	855	427,5	305	305	450	176
DUO 6 DP**	1300	1200	855	427,5	305	305	450	176

* BV/HV configuration
** AV/CV configuration

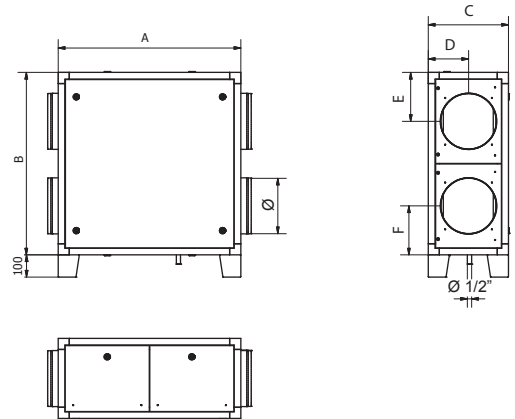

DIMENSIONS (mm) and WEIGHT (Kg) WITH BY-PASS (BP)

MODEL	A	B	C	D	E	F	Ø	Weight
DUO 1 DP	640	640	450	172,5	175	175	200	41
DUO 2 DP	820	820	465	180	220	220	250	56
DUO 3 DP	1040	1040	640	315	225	325	315	107
DUO 4 DP	1270	1270	735	360	240	425	355	146
DUO 5 DP*	1200	1300	855	427,5	305	305	450	171
DUO 5 DP**	1300	1200	855	427,5	305	305	450	171
DUO 6 DP*	1200	1300	855	427,5	305	305	450	176
DUO 6 DP*	1300	1200	855	427,5	305	305	450	176

* configuration BV/HV
** configuration AV/CV

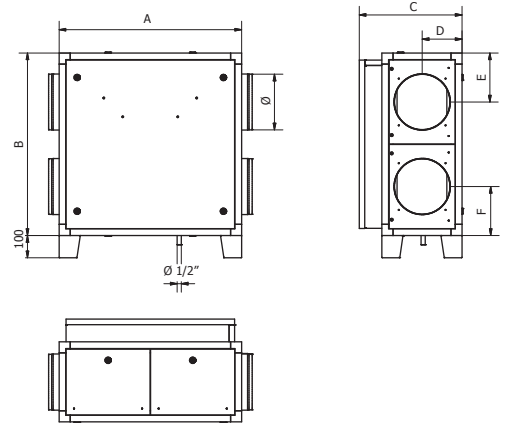

**VERTICAL CONFIGURATION
- front view side inspection -**

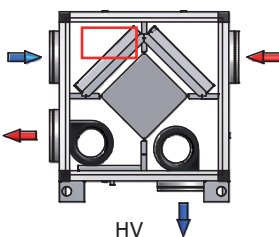
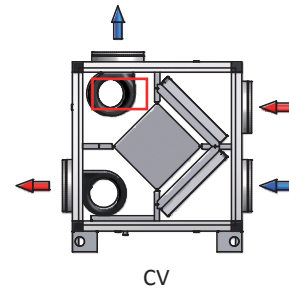
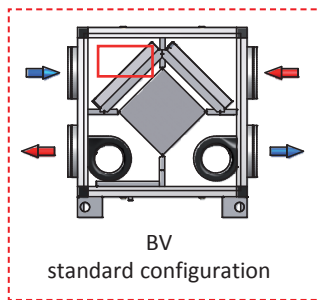
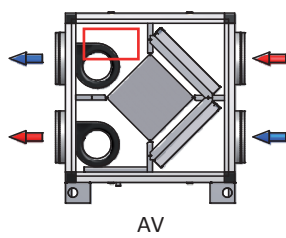

Legend

- Electric board
- Fresh air
- Exhaust air



CEILING MOUNTED

MINIMUM REQUIRED SPACE FOR MAINTENANCE (mm)

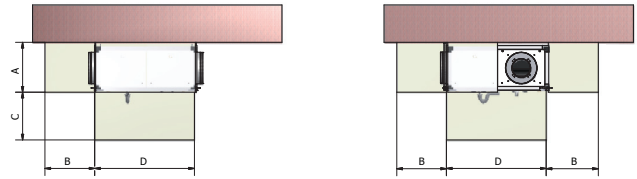
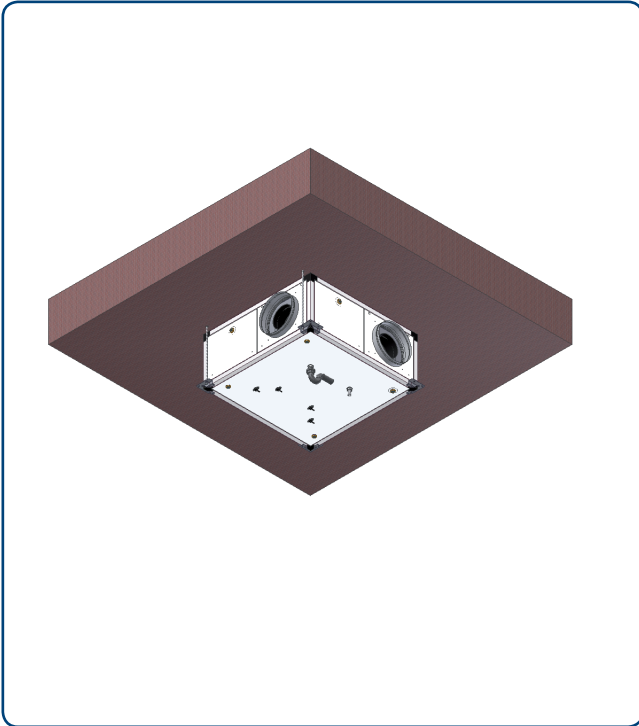

MODEL	A	B	C	D
DUO 1 DP HE	345	400	400	640
DUO 2 DP HE	360	400	400	820
DUO 3 DP HE	535	400	600	1040
DUO 4 DP HE	630	500	700	1270
DUO 5 DP HE	855	500	900	1300
DUO 6 DP HE	855	500	900	1300

FLOOR MOUNTED

MINIMUM REQUIRED SPACE FOR MAINTENANCE (mm)

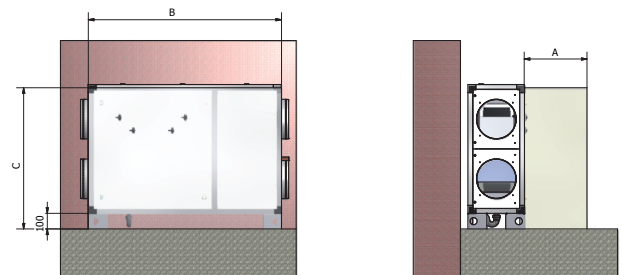
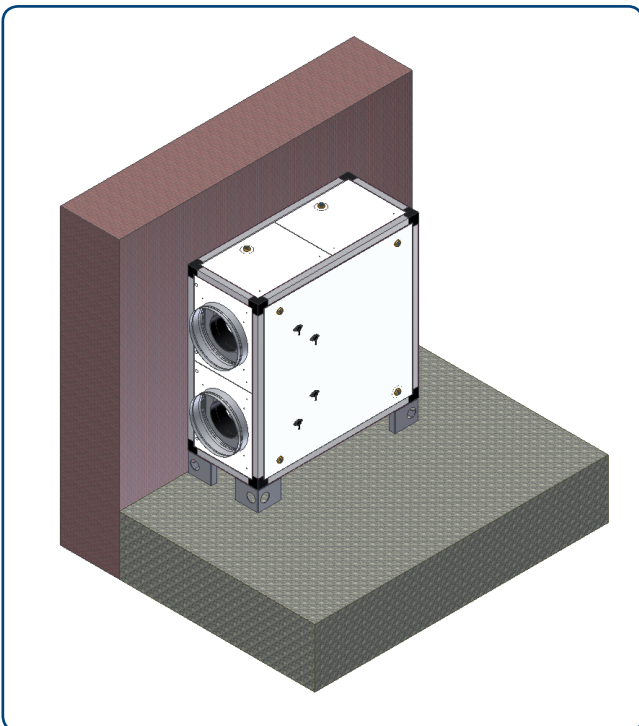

	A	B	C
DUO 1 DP	400	960	740
DUO 2 DP	400	1230	920
DUO 3 DP	600	1560	1140
DUO 4 DP	700	1900	1370
DUO 5 DP	900	1550	1300
DUO 6 DP	900	1550	1300

*UTEK s.r.l. reserves the right to make modifications
to their products without giving prior notice to third parties.*

Air Stream Ltd. | st. V. Jukovskogo, 20 | 49000 Dnipro Ukraine
Fax +380567359979 | www.air-stream.com.ua | info@air-stream.com.ua

 *Air Stream Ltd*

UTEK