



indoor air quality and energy saving

TECHNICAL DATA



HRU-EX



HEAT RECOVERY VENTILATION UNITS with INTEGRATED AIR/AIR HEAT PUMP (CLIMATIZATION)



HRU-EX

HRU-EX is an active recovery unit for heating, cooling and air renewal of the environments (medium efficiency).

PERFORMANCE

HRU-EX can operate either as a passive recovery and as an active thermodynamic recovery and is particularly suitable for residential premises, commercial or collective residential buildings. The unit is supplied in plug-and-play version for a 'quick and simplified installation

STRUCTURE

The unit is composed of a monobloc inclusive of each component for the correct operation: fans, cooling circuit, air filtration sections and cross-flow heat exchanger (medium efficiency). The unit frame is manufactured using a profiled extruded aluminium frame and 36 mm thick sandwich panels, insulated in polyurethane foam. The panels and inner parts are manufactured in Aluzinc[®], material that ensures high strength against corrosion and oxidation. The isolation of the panels is made with insulating that allow to have low noise and reduced transmittances during the operation of the unit. HRU-EX is equipped with electronic backward blade ventilators (compliant Erp2015). The heat exchanger is made of aluminum cross-flow with a medium efficiency (summer and winter operation) and the rotary or scroll compressor (high efficiency) has a thermal protector incorporated. Inside the unit there are two filters with filtration class ePM10 50% (M5) and ePM2,5 70% (F7) easily extractable. The system is managed by an electronic evolved but easy to manage.

MAIN FEATURES

ACTIVE THERMODYNAMIC RECOVERY: The unit allows the recovery of active energy of the exhaust air. The thermodynamic recovery allows, thanks to its refrigerant circuit, to provide energy to the environment in higher quantities than the energy subtracted from the ventilation.

COOLING CIRCUIT: made of copper brazed full of: high efficiency compressor, filter drier, finned coils, solenoids, valves, electronic expansion valve, liquid receiver, pressure transducers and safety devices.

ADJUSTMENT: electric board in the unit with microprocessor and dedicated control which allows to manage:

- the temperature of the air: with room air probe (the supply-air is self-regulating to maintain the T recovery), or air delivery probe
- the fans
- the temperature probes inside the machine
- dirty filters with differential pressure sensors
- management of the defrosting algorithm optimized for operation at low temperatures
- 3-way valve 0-10 Volt for H₂O battery management after cooling / heating

Prepared for MODBUS RTU RS 485.

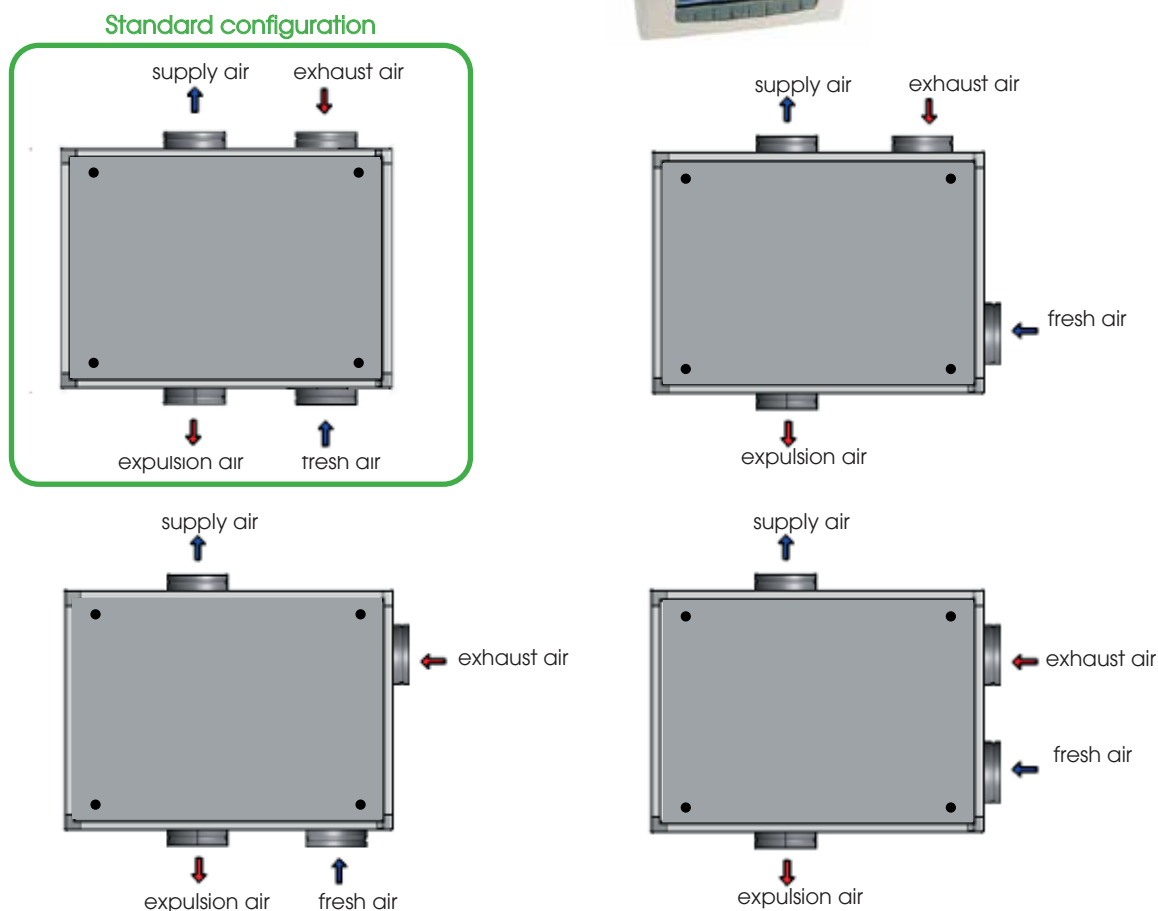

The units are views from above



Counterflow heat exchanger made of aluminum manufactured by RECUPERATOR
RECUPERATOR participates in the Eurovent Certification Program



PERFORMANCES

The unit must be ducted properly: UTEK authorizes the use only according to its performance diagram shown into this catalogue
The declared performances are with CLEAN filters, and guaranteed ONLY with the original filters UTEK low pressure drop.

HRU-EX 1

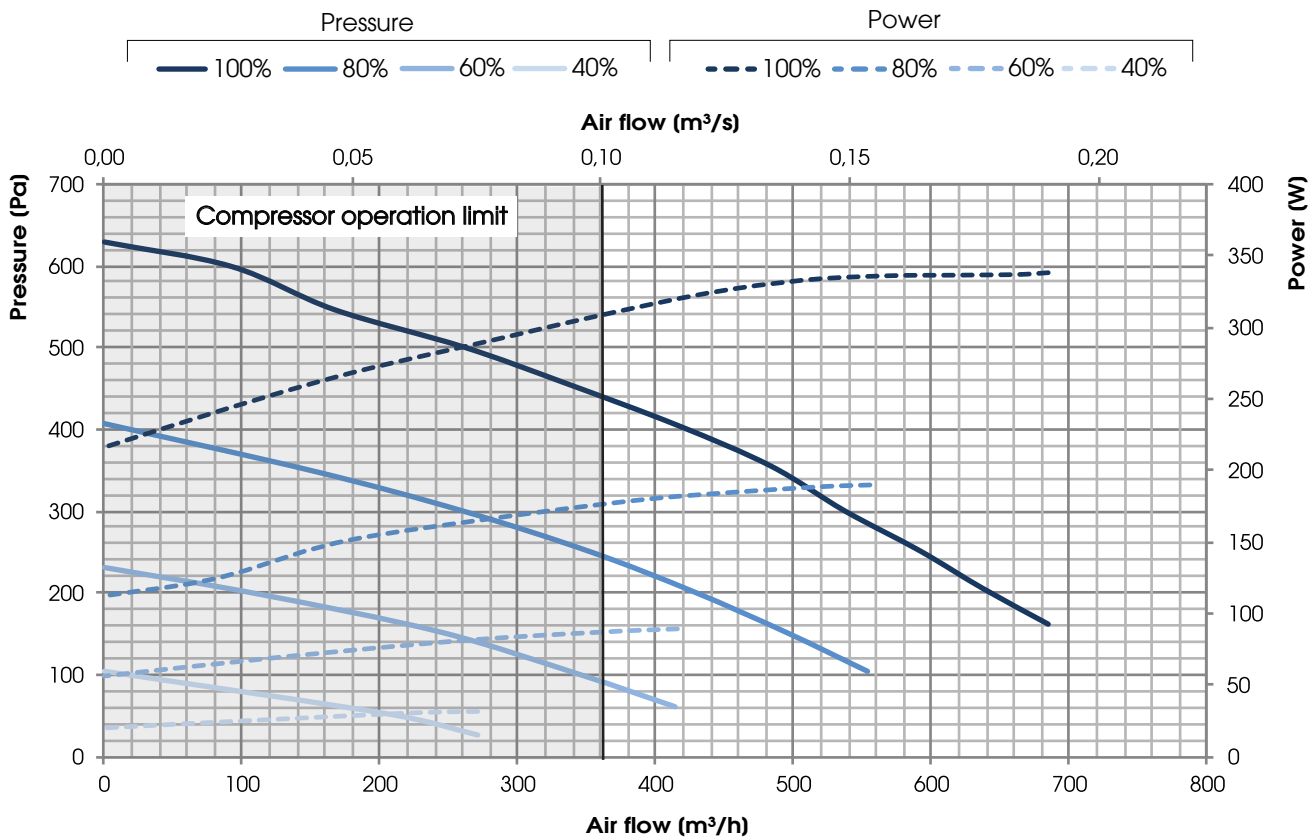

HRU-EX 2

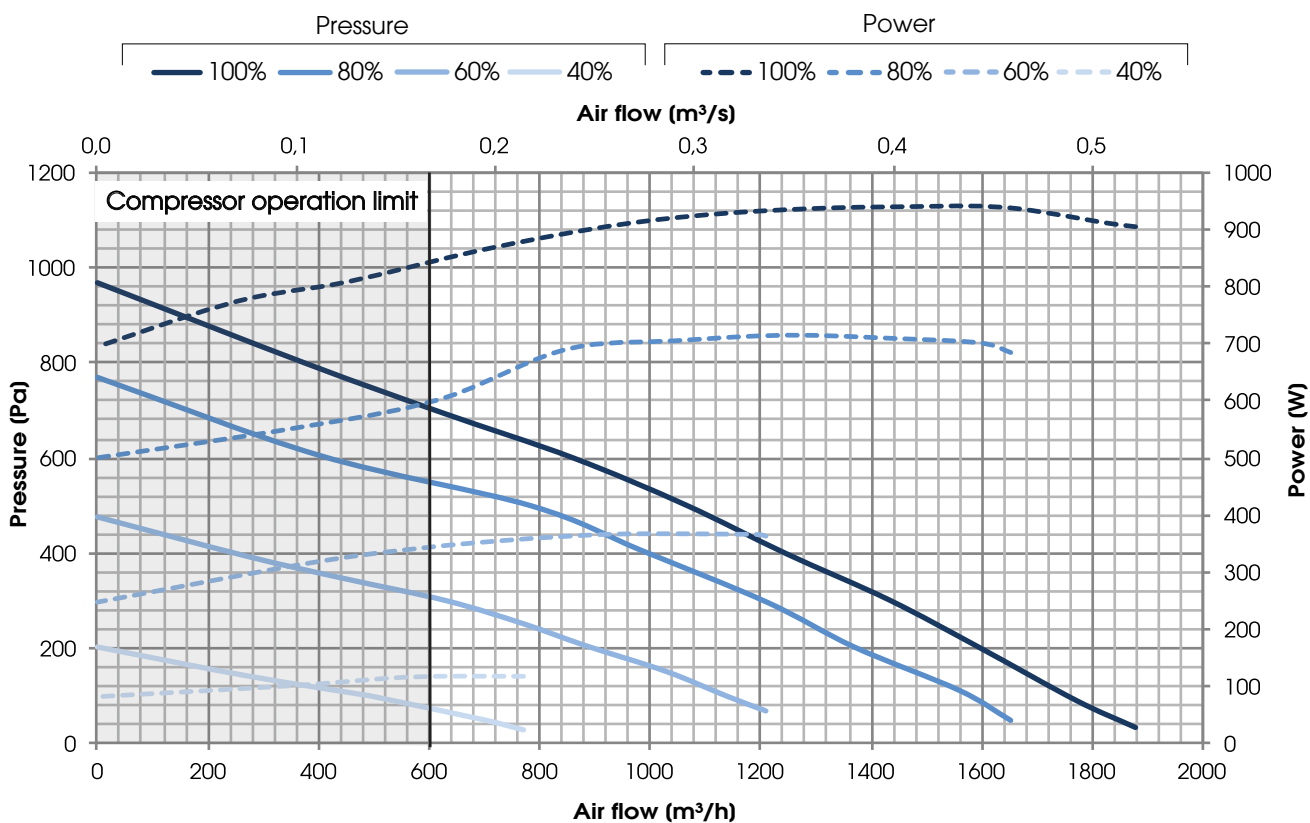



PERFORMANCES

The unit must be ducted properly: UTEK authorizes the use only according to its performance diagram shown into this catalogue
The declared performances are with CLEAN filters, and guaranteed ONLY with the original filters UTEK low pressure drop.

HRU-EX 3

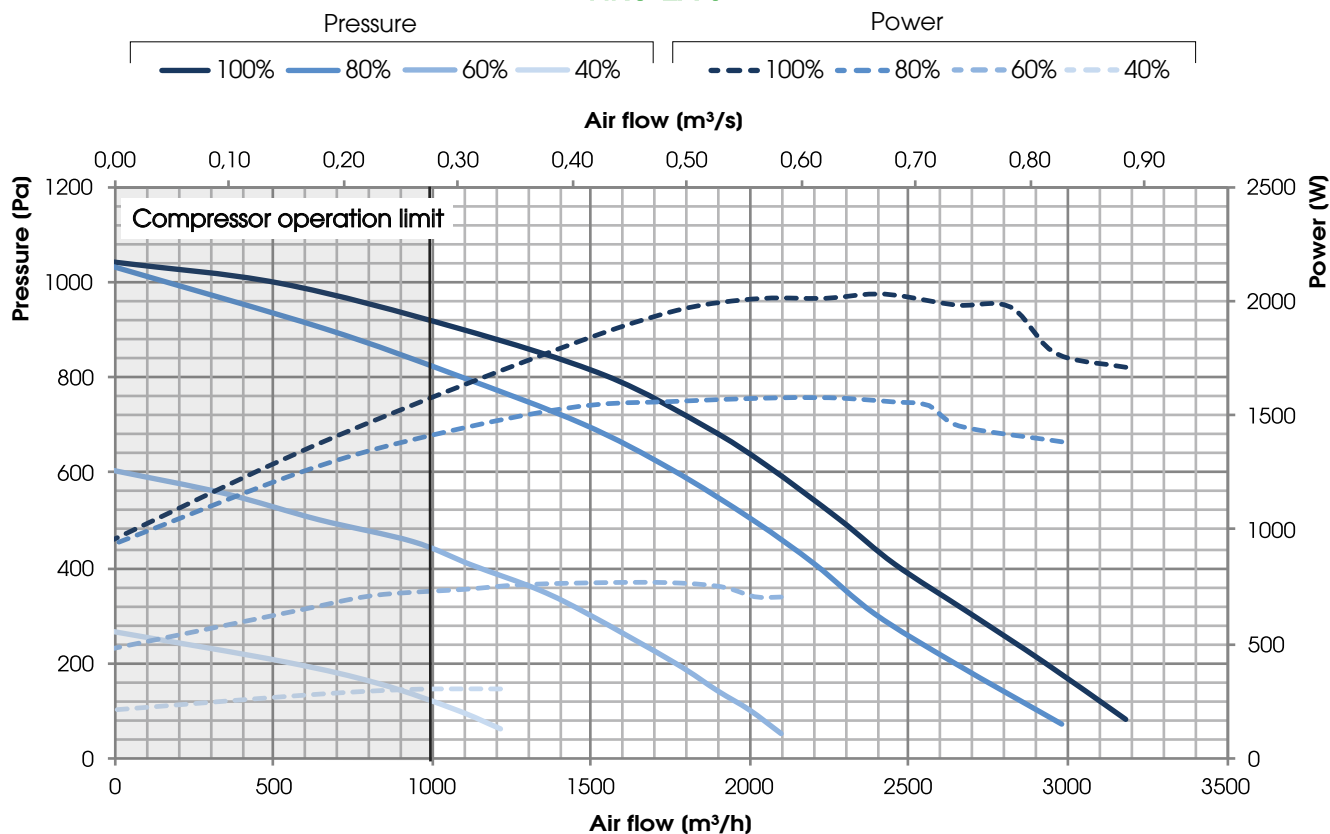

HRU-EX 4

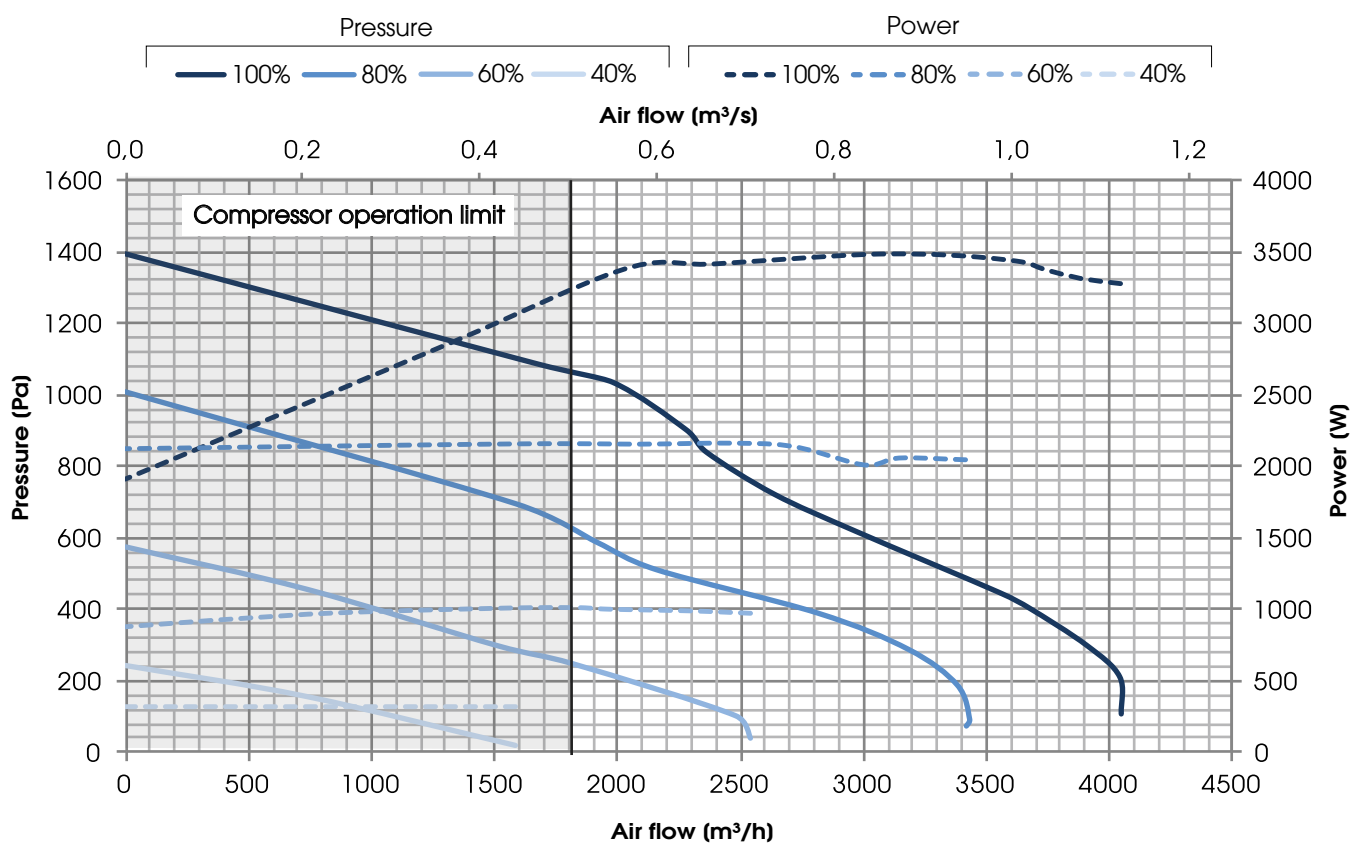



PERFORMANCES

The unit must be ducted properly: UTEK authorizes the use only according to its performance diagram shown into this catalogue
The declared performances are with CLEAN filters, and guaranteed ONLY with the original filters UTEK low pressure drop.

HRU-EX 5

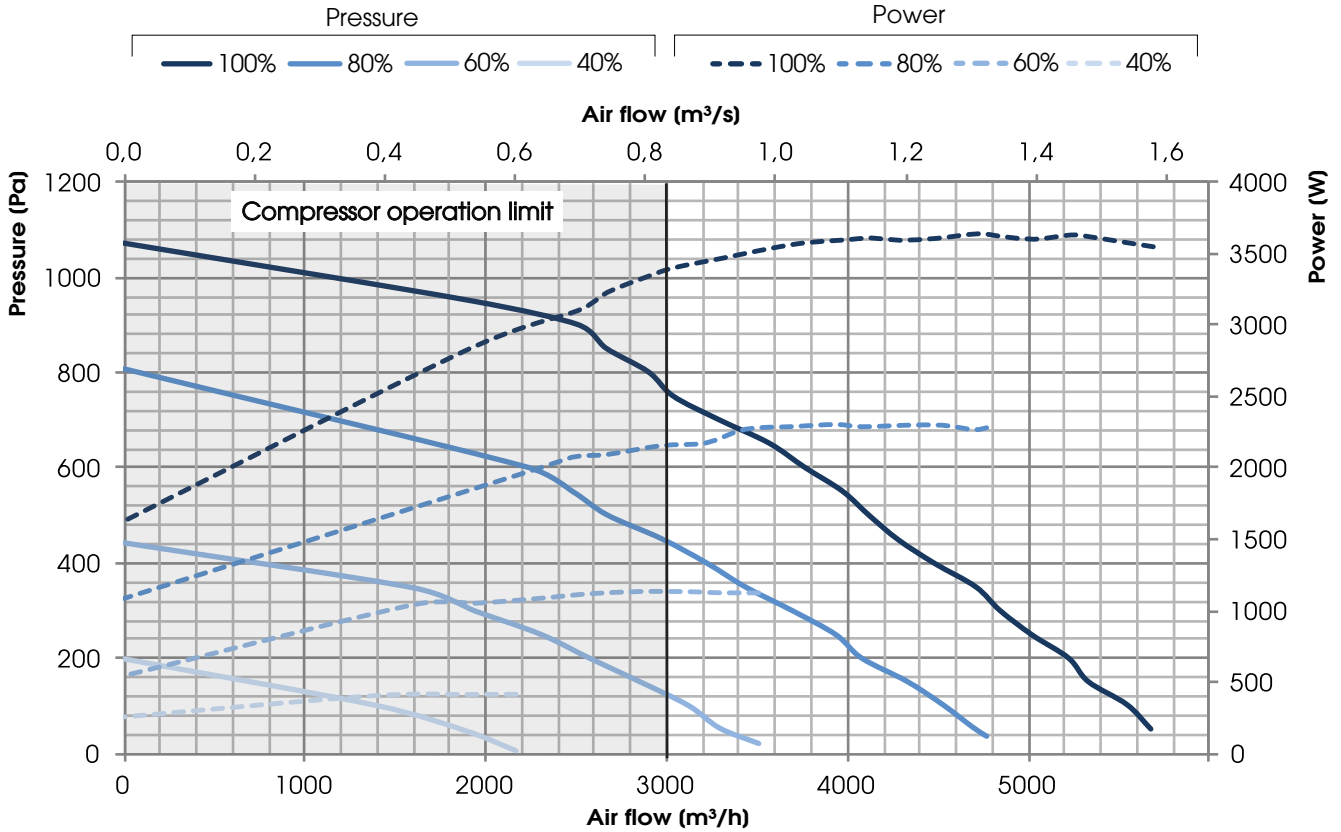

HEAT RECOVERY PERFORMANCE (sensible efficiency)

Values referred to the following conditions (UNI EN 13141-7): T_{bs} external air 5°C; U.R. external 72%; T_{bs} environment 25°C; U.R. environment 28%

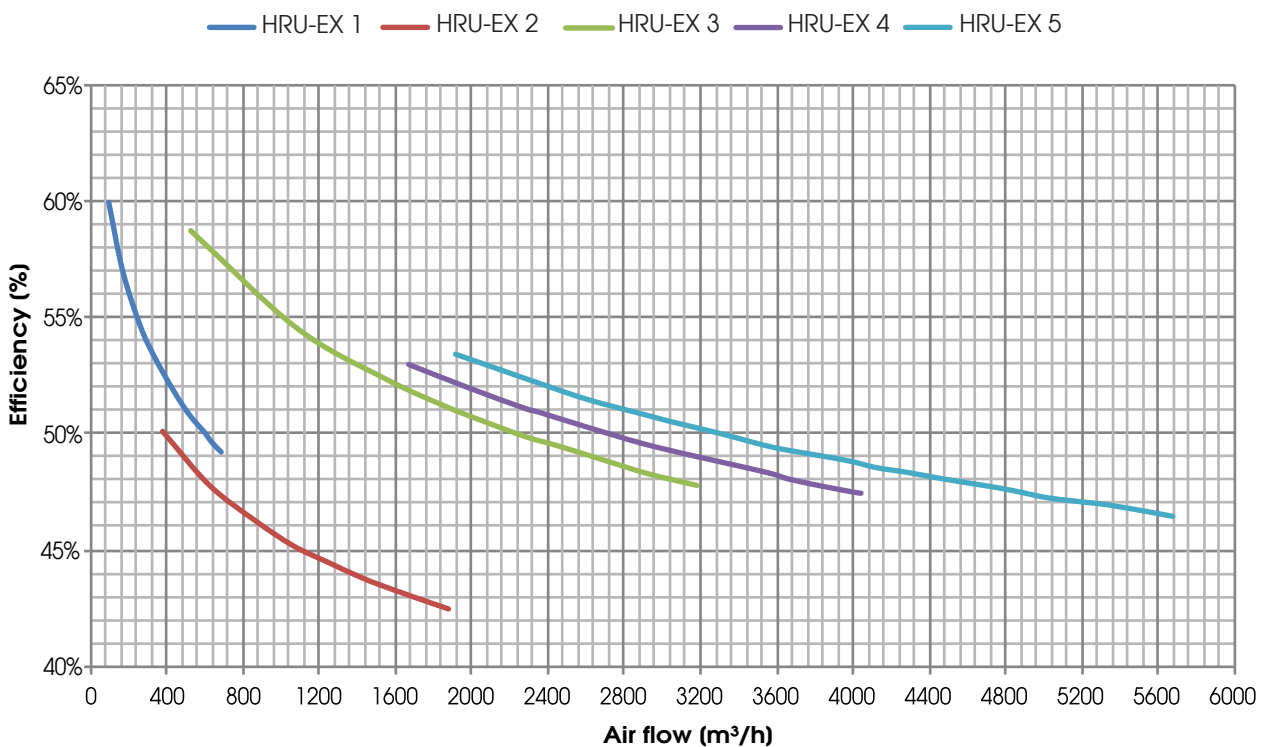



TECHNICAL DATA FOR WINTER OPERATION

	HRU-EX 1	HRU-EX 2	HRU-EX 3	HRU-EX 4	HRU-EX 5
PASSIVE RECOVERY					
Thermal potential (kW) (1)	2,3	4,2	11,2	15,4	22,4
ACTIVE RECOVERY					
Potenzialità termica (kW) (1)	2,82	5,03	13	18,2	24,4
Absorbed potential (kW)	0,58	1,12	2,7	3,4	5,2
COP	4,86	4,49	4,81	5,35	4,69
TOTAL RECOVERY					
Global COP	8,82	8,25	8,96	9,88	9
Inlet air temperature (C°)	22,1	21,9	23,2	22,6	22,1
Potenzialità termica (kW) (1)	5,12	9,25	24,2	33,6	46,8

(1) Outdoor air -5 °/ 80% RH - Indoor air 20 °/ 50% RH - Nominal flow rate

TECHNICAL DATA FOR SUMMER OPERATION

	HRU-EX 1	HRU-EX 2	HRU-EX 3	HRU-EX 4	HRU-EX 5
PASSIVE RECOVERY					
Cooling capacity (kW) (1)	0,4	0,76	2,08	2,85	4,22
ACTIVE RECOVERY					
Cooling capacity (kW) (1)	2,68	5,32	12,71	18,4	25,1
Absorbed potential (kW)	0,79	1,29	3,89	5,5	7,3
EER	3,39	4,12	3,26	3,34	3,43
TOTAL RECOVERY					
Global EER	8,8	4,71	3,8	3,86	4
Temperature/humidity of inlet air (C°/U%)	19,7/87,2	19,6/87,9	19,9/86	19,9/86,9	19,9/85
Cooling capacity (kW) (1)	3,08	6,08	14,79	21,25	29,32

(1) Outdoor air 30°/60% RH - Indoor air 25°/50% RH - Nominal flow rate

GENERIC TECHNICAL DATA

	HRU-EX 1	HRU-EX 2	HRU-EX 3	HRU-EX 4	HRU-EX 5
Fan	Double suction centrifuges				
N° fan	2				
Nominal air flow (m ² /h)	500	1000	2500	3500	5000
Useful pressure on the renewal side (Pa)	200	199	180	100	230
Useful pressure on the expulsion side (Pa)	124	178	140	85	186
Type of compressor	High efficiency rotary		High efficiency scroll		
Refrigerant gas R410A (kg)	1,75	2,70	3,20	3,70	5,30
Passive heat recovery	Cross-flow aluminum plates				
Minimum unit efficiency (%) (1)	55	50,5	53,7	52,6	51,3
Filters	ePM10 50% (ex M5)/ePM1 70% (ex F7)				
Max absorbed power fans (kW)	0,17	0,44	1,00	1,65	1,85
Max current absorbed fans (A)	1,4	2,8	1,6	2,5	2,9
Max power absorbed compressors (kW)	1,06	1,83	5,04	7,23	9,39
Max current absorbed compressors (A)	4,75	8,57	8,6	12,2	15,9
Supply voltage (V/ph/Hz)	230/1/50	230/1/50	400/3/50	400/3/50	400/3/50
Max total power absorbed (kW)	1,23	2,27	6,04	8,88	11,2
Max total current absorbed (A)	6,15	11,3	10,2	14,7	18,8
Degree of protection (IP)	20	20	20	20	20
Sound pressure (dB(A)) (2)	48	53	56	61	68

(1) Outside air -5°/80% UR - Inside air 20°/50% UR - nominal air flow

(2) dati referred to 3 mt of free field distance

VALUES ACCORDING TO UNI EN 1886: 2008

MOD.	DEFORMATION CASE	LEAKAGE CASE	FILTERS CLASS	THERMAL TRANSMITTANCE	THERMAL BRIDGE
HRU-EX 1	D1 (M)	L3 (M)	F7 (M)	T4 (M)	TB3 (M)
HRU-EX 2	D1 (M)	L3 (M)	F7 (M)	T4 (M)	TB3 (M)
HRU-EX 3	D1 (M)	L3 (M)	F7 (M)	T4 (M)	TB3 (M)
HRU-EX 4	D1 (M)	L3 (M)	F7 (M)	T4 (M)	TB3 (M)
HRU-EX 5	D1 (M)	L3 (M)	F7 (M)	T4 (M)	TB3 (M)



TEST LEAKAGE (UNI EN 13141-7)

LEAKAGE	TEST CONDITIONS	HRU-EX 1	HRU-EX 2	HRU-EX 3	HRU-EX 4	HRU-EX 5
OUTSIDE	Positive pressure 400 Pa	A2	A2	A2	A1	A1
OUTSIDE	Negative pressure 400 Pa	A2	A1	A2	A1	A1
INSIDE	Pressure difference 250 Pa	A2	A2	A2	A2	A2

NOISE LEVEL

L_w Sound power level taken in accordance to UNI EN ISO 3747 - CLASS 3

				NOISE FROM THE CASE (dB)							
		Compressor		125 Hz	250 Hz	500 Hz	1000 Hz	2000 Hz	4000 Hz	8000 Hz	L _w dB(A)
HRU-EX 1	100%	OFF		65,9	68,0	59,1	53,8	48,7	43,1	46,5	62,4
		ON		66,7	69,2	59,6	54,4	48,5	43,3	46,7	63,3
HRU-EX 2	100%	OFF		73,1	69,2	60,2	56,3	51,3	48,2	50,1	64,7
		ON		75,8	70,9	62,0	56,8	52,2	48,3	50,7	66,3
HRU-EX 3	100%	OFF		74,7	72,7	65,0	61,7	51,4	45,4	47,6	68,1
		ON		74,2	73,4	65,9	61,9	51,1	45,7	47,5	68,6
HRU-EX 4	100%	OFF		80,2	76,3	65,4	60,1	52,7	47,7	50,0	70,6
		ON		81,0	78,3	65,5	59,8	53,6	47,8	50,6	71,9
HRU-EX 5	100%	OFF		81,9	79,3	70,7	65,3	58,1	55,4	58,7	74,2
		ON		81,5	81,5	71,5	65,8	58,6	55,6	59,1	75,5

				NOISE IN THE DUCTS (dB)							
		Compressor		125 Hz	250 Hz	500 Hz	1000 Hz	2000 Hz	4000 Hz	8000 Hz	L _w dB(A)
HRU-EX 1	100%	OFF		63,4	66,3	65,0	65,9	61,2	60,7	67,2	71,2
		ON		64,6	67,3	65,0	64,8	62,3	60,5	67,3	71,2
HRU-EX 2	100%	OFF		69,6	74,2	68,8	70,0	64,4	63,6	66,4	74,4
		ON		72,0	75,2	70,1	70,7	65,0	64,3	66,8	75,2
HRU-EX 3	100%	OFF		71,4	74,0	74,0	71,5	64,3	65,2	68,8	76,4
		ON		71,8	74,1	73,7	71,6	64,1	65,1	68,6	76,3
HRU-EX 4	100%	OFF		83,6	83,4	76,9	74,6	68,9	68,6	72,9	80,9
		ON		83,6	83,6	76,5	75,2	69,2	69,8	73,6	81,2
HRU-EX 5	100%	OFF		79,3	80,9	80,5	78,7	74,8	73,2	77,8	84,1
		ON		80,8	82,0	80,6	78,9	75,3	73,7	78,2	84,5

OPERATION LIMITS

		INTERNAL AIR				
		HRU-EX 1	HRU-EX 2	HRU-EX 3	HRU-EX 4	HRU-EX 5
HEATING (°C)		15/25				
COOLING (°C)		18/28				
		EXTERNAL AIR				
		HRU-EX 1	HRU-EX 2	HRU-EX 3	HRU-EX 4	HRU-EX 5
HEATING (°C)		-20/20				
COOLING (°C)		15/40				

NOTE: the operating limits refer to the operation of the unit and the components installed.

With outside temperatures below 0 ° C, we recommend to provided a electric pre-heating to avoid the continuous evaporator defrost sequences

STANDARD SIPHON (mm)

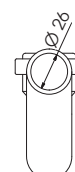
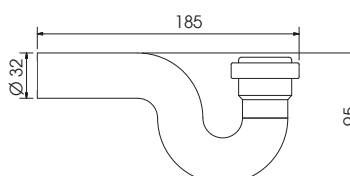



DIMENSIONS (mm) and WEIGHT (kg)

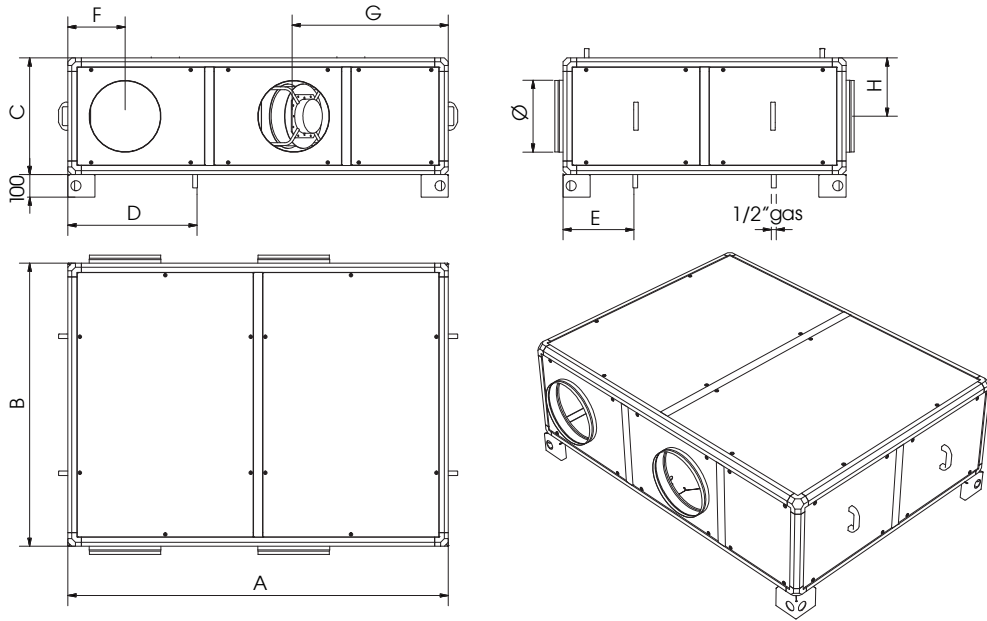

MODEL	A	B	C	∅	D	E	F	G	H	Weight (kg)
HRU-EX 1	1400	925	415	200	495	295	245	470	208	105
HRU-EX 2	1680	1250	515	315	560	320	250	685	260	178
HRU-EX 3	1960	1430	620	355	645	390	285	615	260	262
HRU-EX 4	1960	1430	720	400	645	390	285	615	360	306
HRU-EX 5	2238	1612	922	500	722	372	335	660	461	475

INSTALLATION HRU-EX

Minimum required space for maintenance (mm)

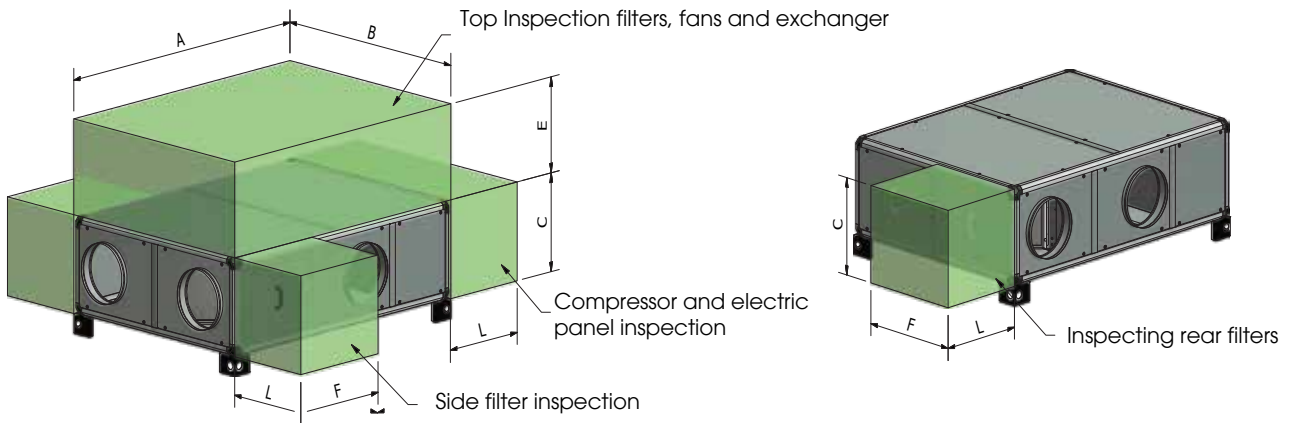

Replacing fans

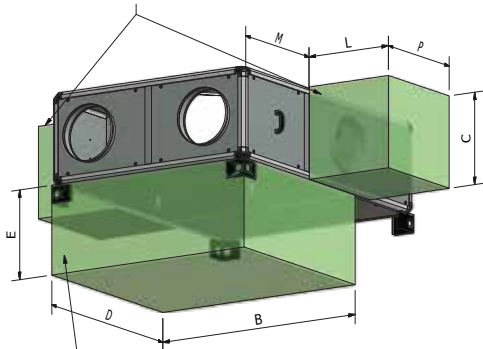

Sizes 1-2 inspection of the filters and exchanger from below
 Sizes 3-4-5 inspection of the filters from below

MODEL	A	B	C	D	E	F	L	M	P
HRU-EX 1	1400	925	415	1400	400	460	500	480	600
HRU-EX 2	1680	1250	515	1100	500	620	500	640	560
HRU-EX 3	1960	1430	620	530	600	530	500	1000	490
HRU-EX 4	1960	1430	720	530	700	530	500	1000	490
HRU-EX 5	2240	1610	920	625	500	620	500	1290	590

CLA & UTEK reserves the right to at any time the necessary changes to improve products without prior notice .

Dear Customer

Thanks for your attention to the product UTEK , designed and manufactured to ensure the real values to the User : Quality, Safety and Savings on working.



Made in Italy

**COMPANY WITH
QUALITY SYSTEM
CERTIFIED BY DNV GL
ISO 9001**



il Concessionario

HRU-EX_2019_EN



HEAT RECOVERY VENTILATION UNITS with INTEGRATED
AIR/AIR HEAT PUMP (CLIMATIZATION and DEHUMIDIFICATION)